

# HEATHKIT<sup>®</sup> MANUAL

*for the*

**UltraPro<sup>®</sup>  
CW KEYBOARD**  
Model HD-8999

595-2941

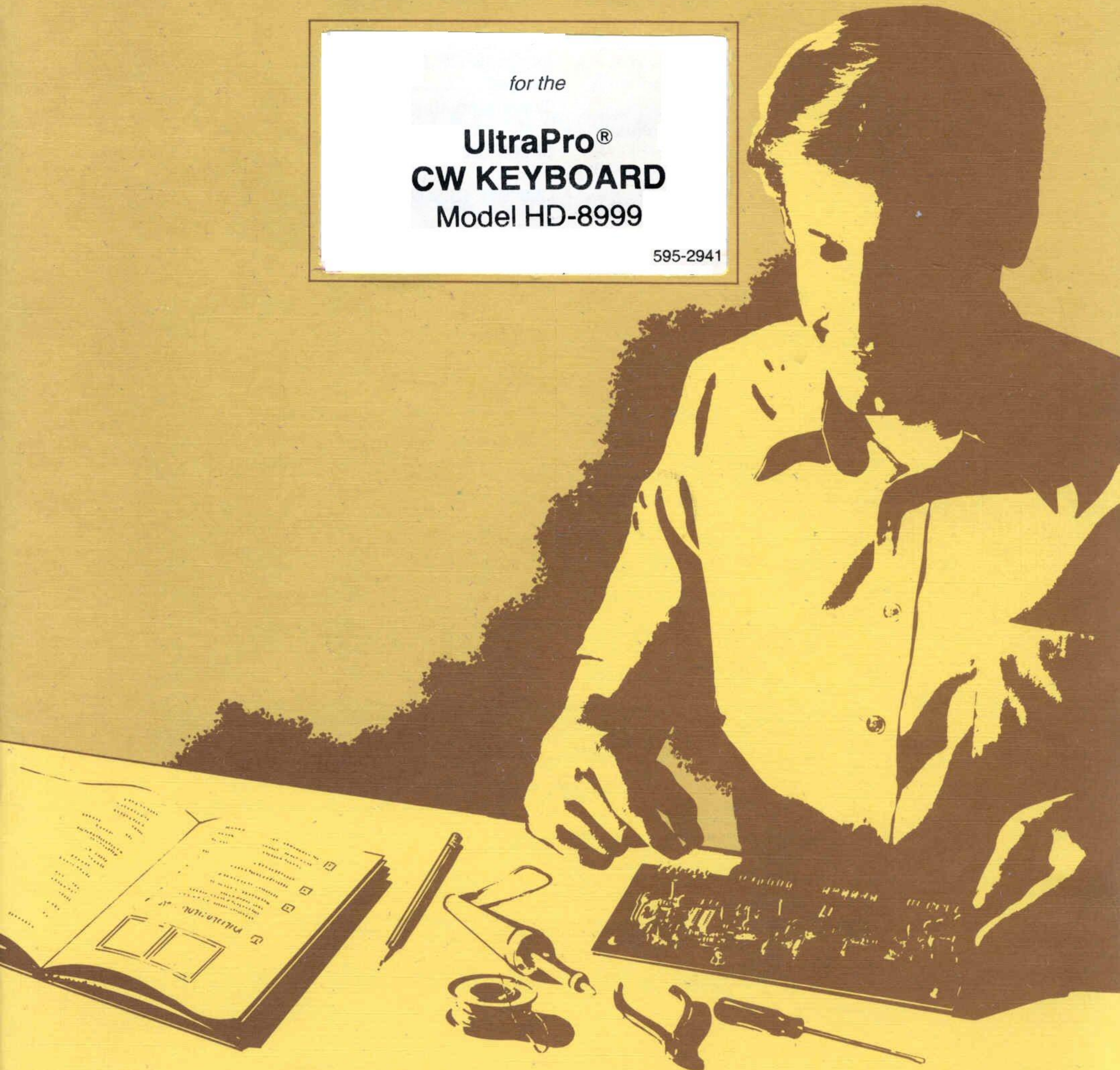

HEATH COMPANY • BENTON HARBOR, MICHIGAN

## HEATH COMPANY PHONE DIRECTORY

The following telephone numbers are direct lines to the departments listed:

Kit orders and delivery information ..... (616) 982-3411  
Credit ..... (616) 982-3561  
Replacement Parts ..... (616) 982-3571

### Technical Assistance Phone Numbers

8:00 A.M. to 12 P.M. and 1:00 P.M. to 4:30 P.M., EST, Weekdays Only

R/C, Audio, and Electronic Organs ..... (616) 982-3310  
Amateur Radio ..... (616) 982-3296  
Test Equipment, Weather Instruments and  
Home Clocks ..... (616) 982-3315  
Television ..... (616) 982-3307  
Aircraft, Marine, Security, Scanners, Automotive,  
Appliances and General Products ..... (616) 982-3496  
Computers — Hardware ..... (616) 982-3309  
Computers — Software:  
Operating Systems, Languages, Utilities ..... (616) 982-3860  
Application Programs ..... (616) 982-3884  
Heath Craft Wood Works ..... (616) 982-3423



## YOUR HEATHKIT 90-DAY LIMITED WARRANTY

### Consumer Protection Plan for Heathkit Consumer Products

Welcome to the Heath family. We believe you will enjoy assembling your kit and will be pleased with its performance. Please read this Consumer Protection Plan carefully. It is a "LIMITED WARRANTY" as defined in the U.S. Consumer Product Warranty and Federal Trade Commission Improvement Act. This warranty gives you specific legal rights, and you may also have other rights which vary from state to state.

#### Heath's Responsibility

**PARTS** — Replacements for factory defective parts will be supplied free for 90 days from date of purchase. Replacement parts are warranted for the remaining portion of the original warranty period. You can obtain warranty parts direct from Heath Company by writing or telephoning us at (616) 982-3571. And we will pay shipping charges to get those parts to you . . . anywhere in the world.

**SERVICE LABOR** — For a period of 90 days from the date of purchase, any malfunction caused by defective parts or error in design will be corrected at no charge to you. You must deliver the unit at your expense to the Heath factory, any Heathkit Electronic Center (units of Veritechnology Electronics Corporation), or any of our authorized overseas distributors.

**TECHNICAL CONSULTATION** — You will receive free consultation on any problem you might encounter in the assembly or use of your Heathkit product. Just drop us a line or give us a call. Sorry, we cannot accept collect calls.

**NOT COVERED** — The correction of assembly errors, adjustments, calibration, and damage due to misuse, abuse, or negligence are not covered by the warranty. Use of corrosive solder and/or the unauthorized modification of the product or of any furnished component, will void this warranty in its entirety. This warranty does not include reimbursement for inconvenience, loss of use, customer assembly, set-up time, or unauthorized service.

This warranty covers only Heath products and is not extended to other equipment or components that a customer uses in conjunction with our products.

SUCH REPAIR AND REPLACEMENT SHALL BE THE SOLE REMEDY OF THE CUSTOMER AND THERE SHALL BE NO LIABILITY ON THE PART OF HEATH FOR ANY SPECIAL, INDIRECT, INCIDENTAL OR CONSEQUENTIAL DAMAGES, INCLUDING BUT NOT LIMITED TO ANY LOSS OF BUSINESS OR PROFITS, WHETHER OR NOT FORSEEABLE.

Some states do not allow the exclusion or limitation of incidental or consequential damages, so the above limitation or exclusion may not apply to you.

#### Owner's Responsibility

**EFFECTIVE WARRANTY DATE** — Warranty begins on the date of first consumer purchase. You must supply a copy of your proof of purchase when you request warranty service or parts.

**ASSEMBLY** — Before seeking warranty service, you should complete the assembly by carefully following the manual instructions. Heathkit service agencies cannot complete assembly and adjustments that are customer's responsibility.

**ACCESSORY EQUIPMENT** — Performance malfunctions involving other non-Heath accessory equipment, (antennas, audio components, computer peripherals and software, etc.) are not covered by this warranty and are the owner's responsibility.

**SHIPPING UNITS** — Follow the packing instructions published in the assembly manuals. Damage due to inadequate packing cannot be repaired under warranty.

If you are not satisfied with our service (warranty or otherwise) or our products, write directly to our Director of Customer Service, Heath Company, Benton Harbor MI 49022. He will make certain your problems receive immediate, personal attention.

# Heathkit® Manual

*for the*

## **UltraPro® CW KEYBOARD Model HD-8999**

595-2941

HEATH COMPANY  
BENTON HARBOR, MICHIGAN 49022

**Copyright © 1983**  
Heath Company  
*All Rights Reserved*  
Printed in the United States of America

**TABLE OF CONTENTS**

INTRODUCTION .....	3	Operation .....	62
UNPACKING .....	4	Summary of Commands .....	72
ASSEMBLY NOTES .....	5	IN CASE OF DIFFICULTY .....	73
DISPLAY CIRCUIT BOARD .....	9	General .....	73
Parts List .....	9	Troubleshooting Chart .....	75
Step-by-Step Assembly .....	10	SPECIFICATIONS .....	77
MAIN CIRCUIT BOARD .....	15	CIRCUIT DESCRIPTION .....	79
Parts List .....	15	CIRCUIT BOARD X-RAY VIEWS .....	83
Step-by-Step Assembly .....	18	SEMICONDUCTOR IDENTIFICATION	
CHASSIS .....	33	CHARTS .....	85
Parts List .....	33	SCHEMATIC .....	Fold-in
Step-by-Step Assembly .....	35	WARRANTY .....	Inside front cover
INITIAL TESTS .....	51	CUSTOMER SERVICE .....	Inside rear cover
FINAL ASSEMBLY .....	57		
INSTALLATION AND OPERATION .....	59		
Installation .....	59		

## INTRODUCTION

The Heathkit Model HD-8999 UltraPro® CW Keyboard takes the work out of sending Morse Code. A custom microprocessor integrated circuit keeps the parts count low and reliability high, and provides many unique features. The keyboard is attractively styled and "human engineered" for maximum convenience and minimum fatigue. This Keyboard features:

- A professional-quality keyboard, with keytops shaped for most efficient action. The legends are double-shot injection-molded for permanence.
- Ten buffers for storage of text. These buffers are of variable length to avoid wasted memory space. You can selectively protect these buffers against accidental erasure.
- Keyboard-settable operating parameters whose accuracy is insured by a crystal-controlled clock.
- A 64-character "type ahead" buffer, which allows you to type faster than the Keyboard is sending. A three-color, eight-segment LED bar display indicates the fullness of this buffer.
- A large, four-digit LED display, which indicates operating parameters such as speed, spacing, weighting, serial

number, and space remaining in the message memory. It also displays some prompts about the Keyboard operation.

- Built-in diagnostics to pinpoint problems to the particular integrated circuit at fault, and indicate its number on the LED display.
- CMOS memory with battery backup, which retains the buffer contents and protection status when the Keyboard is turned off or unplugged. It also retains the last-used speed, spacing, weighting, and serial number.
- Three different, four-level code practice modes, including one that improves typing proficiency.
- A built-in sidetone oscillator and speaker.

These and many other features are combined with an attractively-styled, lightweight enclosure and will bring many years of trouble-free pleasure to your CW operating.

NOTE: If you intend to operate your Keyboard with an optional AC transformer, please refer to Page 59 and read the information under "Power Source" at this time.

## UNPACKING

DO NOT UNPACK ANY PART OF YOUR KIT  
UNTIL A STEP DIRECTS YOU TO DO SO.

Locate the "Pack Index Sheet" that is packed inside the main shipping carton for your CW Keyboard. Note that the shipping carton is divided into three smaller sections. These sections make up Packs 1 and 2 and the Final Pack, and may be made up of several bags, envelopes, small boxes, and loose parts. Do not unpack any of these parts until a step specifically directs you to do so.

When you check parts against a "Parts List," return any part or group of parts packaged in a bag or other container, with a part number on it, to its container after you identify it. Leave these parts there until you actually use them in a step. This will help prevent you from mixing up the parts, and help you identify the parts when you need them.

Some parts, however, are in a bag or envelope that is not marked with an actual part number, but with a packaging number that begins with the number "173-." These numbers are used for packaging purposes only and do not appear in the Manual "Parts Lists." Open each bag or envelope that is marked with only a "173-" packaging number to identify the parts it contains.

**NOTE:** Never use a "173-" packaging number if you must order a replacement part. Use only the part numbers listed in the Manual Parts List for this purpose.

Save all of the packaging material until you account for all of the parts.

# ASSEMBLY NOTES

## TOOLS

You will need these tools to assemble your kit.

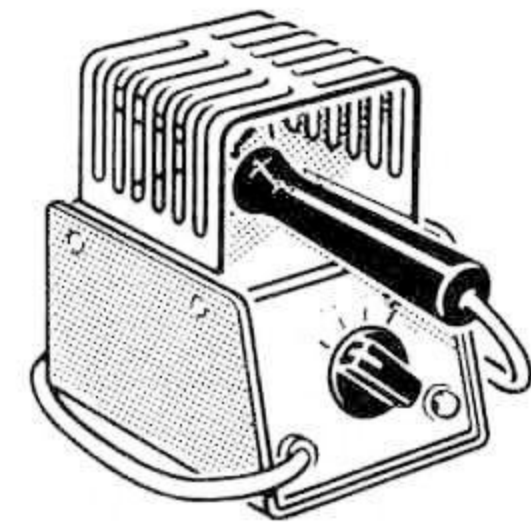
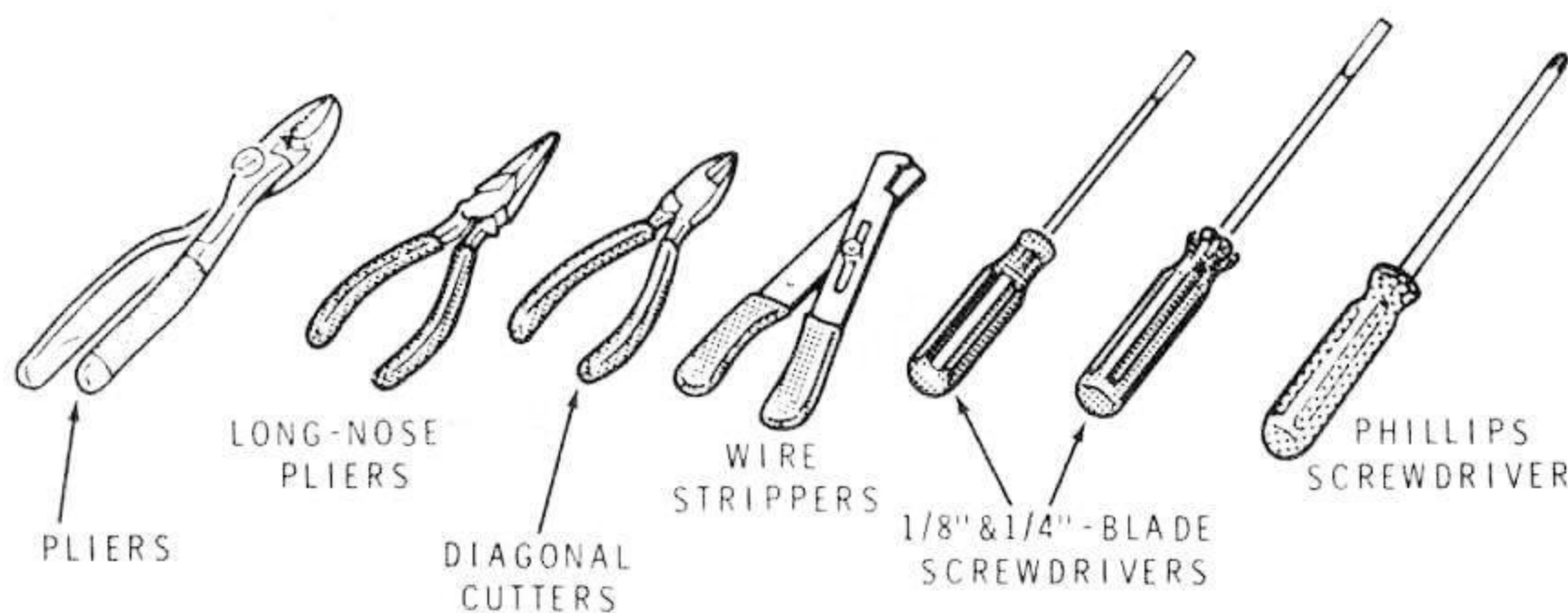

SOLDERING  
IRON

OR

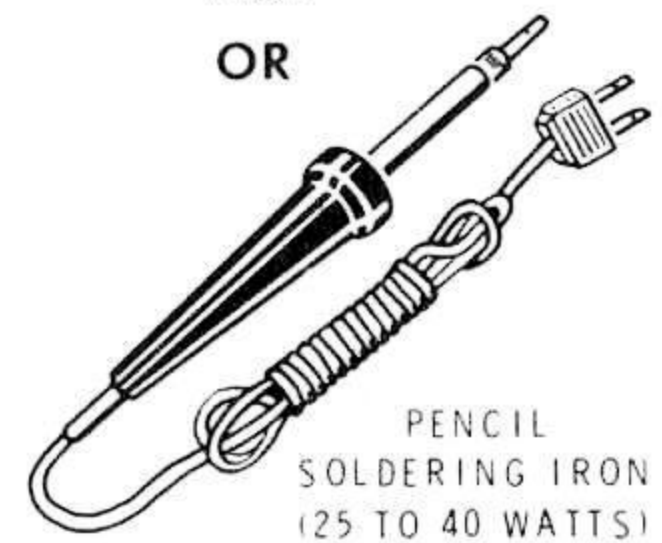

PENCIL  
SOLDERING IRON  
(25 TO 40 WATTS)

### OTHER HELPFUL TOOLS

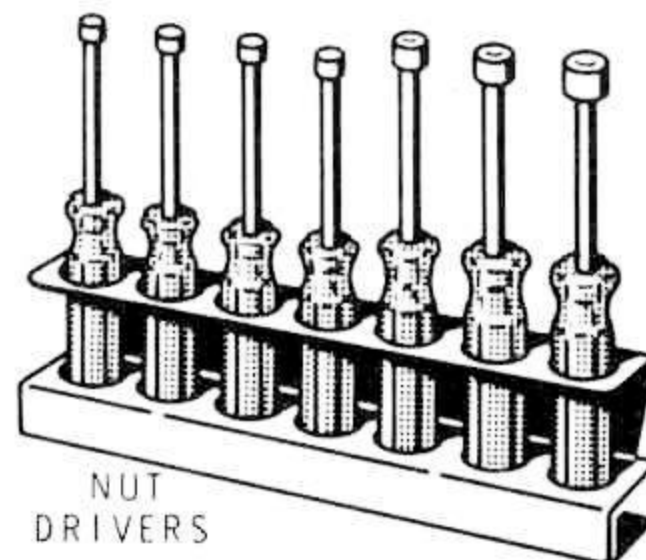
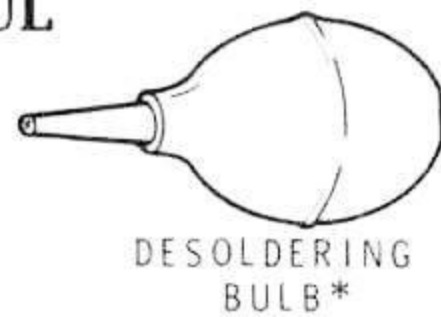

\*TO REMOVE SOLDER FROM CIRCUIT CONNECTIONS.

## ASSEMBLY

- Follow the instructions carefully. Read the entire step before you perform each operation.
- The illustrations in the Manual are called Pictorials and Details. Pictorials show the overall operation for a group of assembly steps; Details generally illustrate a single step. When you are directed to refer to a certain Pictorial "for the following steps," continue using that Pictorial until you are referred to another Pictorial for another group of steps.
- Most kits use a separate "Illustration Booklet" that contains illustrations (Pictorials, Details, etc.) that are too large for the Assembly Manual. Keep the "Illustration Booklet" with the Assembly Manual. The illustrations in it are arranged in Pictorial number sequence.
- Position all parts as shown in the Pictorials.
- Solder a part or a group of parts only when you are instructed to do so.

6. Each circuit part in an electronic kit has its own component number (R2, C4, etc.). Use these numbers when you want to identify the same part in the various sections of the Manual. These numbers, which are especially useful if a part has to be replaced, appear:
- In the Parts List,
  - At the beginning of each step where a component is installed,
  - In some illustrations,
  - In the Schematic,
  - In the section at the rear of the Manual.
7. When you are instructed to cut something to a particular length, use the scales (rulers) provided at the bottom of the Manual pages.

**SAFETY WARNING: Avoid eye injury when you cut off excessive lead lengths. Hold the leads so they cannot fly toward your eyes.**

## SOLDERING

Soldering is one of the most important operations you will perform while assembling your kit. A good solder connection will form an electrical connection between two parts, such as a component lead and a circuit board foil. A bad solder connection could prevent an otherwise well-assembled kit from operating properly.

It is easy to make a good solder connection if you follow a few simple rules:

1. Use the right type of soldering iron. A 25 to 40-watt pencil soldering iron with a 1/16" chisel or pyramid tip works best.
2. Keep the soldering iron tip clean. Wipe it often on a wet sponge or cloth; then apply solder to the tip to give the entire tip a wet look. This process is called tinning, and it will protect the tip and enable you to make good connections. When solder tends to "ball" or does not stick to the tip, the tip needs to be cleaned and retinned.

NOTE: Always use rosin core, radio-type solder (60:40 or 50:50 tin-lead content) for all of the soldering in this kit. This is the type we have supplied with the parts. The Warranty will be void and we will not service any kit in which acid core solder or paste has been used.



## PARTS

**Resistors** are identified in Parts Lists and steps by their resistance value in  $\Omega$  (ohms),  $k\Omega$  (kilohms), or  $M\Omega$  (megohms). They are usually identified by a color code and four or five color bands, where each color represents a number. These colors (except for the last band, which indicates a resistor's "tolerance") will be given in the steps in their proper order. Therefore, the following color code is given for information only. NOTE: Occasionally, a "precision" or "power" resistor may have the value stamped on it.

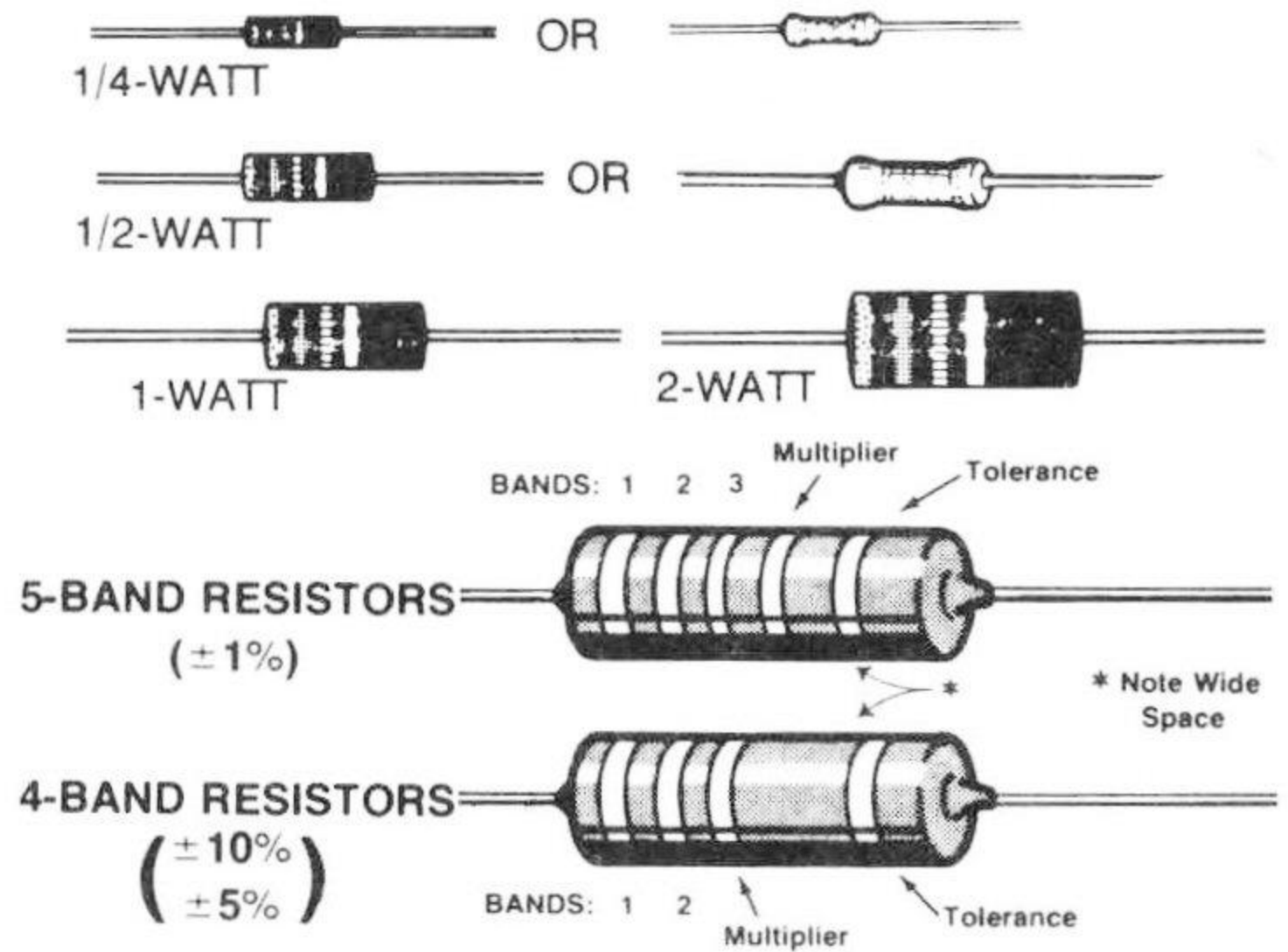

Band 1 1st Digit		Band 2 2nd Digit		Band 3 (if used) 3rd Digit		Multiplier		Resistance Tolerance	
Color	Digit	Color	Digit	Color	Digit	Color	Multiplier	Color	Tolerance
Black	0	Black	0	Black	0	Black	1	Silver	± 10%
Brown	1	Brown	1	Brown	1	Brown	10	Gold	± 5%
Red	2	Red	2	Red	2	Red	100	Brown	± 1%
Orange	3	Orange	3	Orange	3	Orange	1,000		
Yellow	4	Yellow	4	Yellow	4	Yellow	10,000		
Green	5	Green	5	Green	5	Green	100,000		
Blue	6	Blue	6	Blue	6	Blue	1,000,000		
Violet	7	Violet	7	Violet	7	Silver	0.01		
Gray	8	Gray	8	Gray	8	Gold	0.1		
White	9	White	9	White	9				

**Capacitors** will be called out by their capacitance value in  $\mu F$  (microfarads) or pF (picofarads) and type: ceramic, Mylar\*, electrolytic, etc. Some capacitors may have their value printed in the following manner:

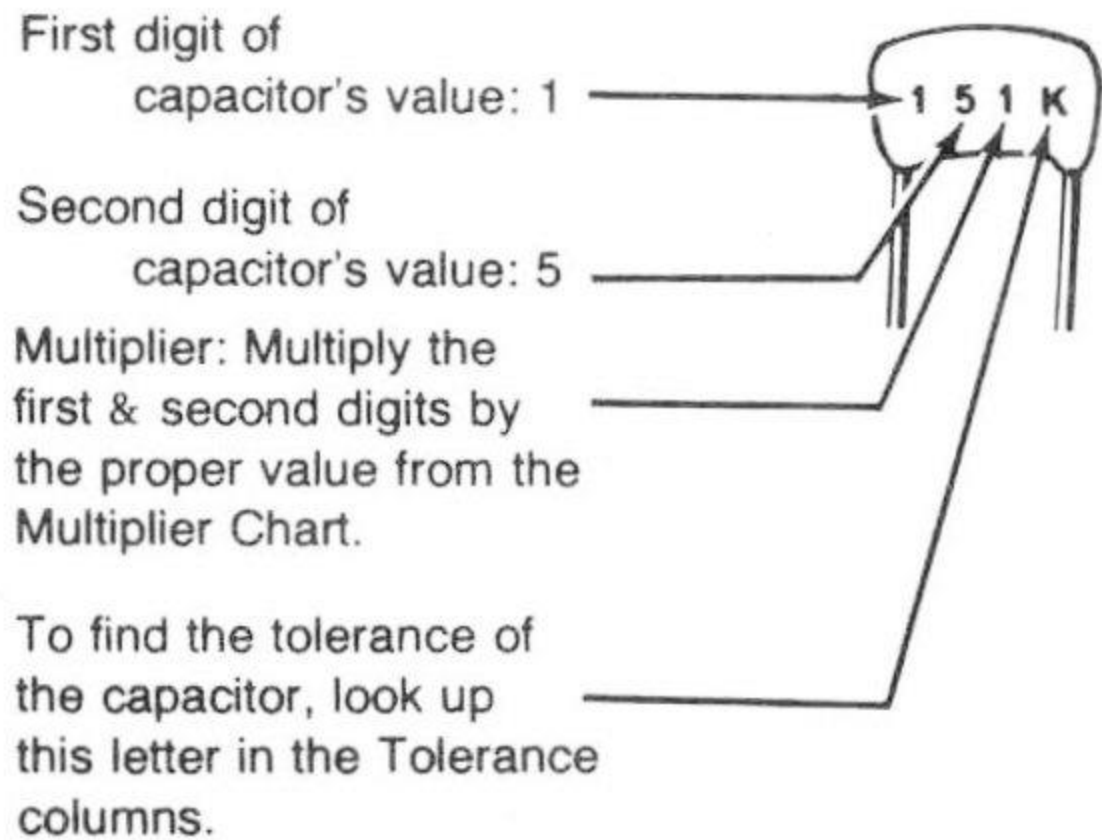

**EXAMPLES:**

151K =  $15 \times 10 = 150 \text{ pF}$   
 759 =  $75 \times 0.1 = 7.5 \text{ pF}$

NOTE: The letter "R" may be used at times to signify a decimal point: as in: 2R2 = 2.2 (pF or  $\mu F$ ).

MULTIPLIER		TOLERANCE OF CAPACITOR		
FOR THE NUMBER:	MULTIPLY BY:	10 pF OR LESS	LETTER	OVER 10 pF
0	1	± 0.1 pF	B	
1	10	± 0.25 pF	C	
2	100	± 0.5 pF	D	
3	1000	± 1.0 pF	F	± 1%
4	10,000	± 2.0 pF	G	± 2%
5	100,000		H	± 3%
			J	± 5%
8	0.01		K	± 10%
9	0.1		M	± 20%

\*DuPont Registered Trademark.



# DISPLAY CIRCUIT BOARD

## PARTS LIST

Refer to the Pack Index Sheet and locate Pack #1. Then remove the parts from this pack and check each part against the following list. The key numbers correspond to the numbers on the "Display Circuit Board Parts Pictorial" (Illustration Booklet, Page 1). Return any part that is packed in an individual envelope, with the part number on it, back into its envelope until that part is called for in a step. Do not

throw away any packing material until you account for all the parts.

To order a replacement part, always include the PART NUMBER. Use the Parts Order Form furnished with this kit. If a Parts Order Form is not available, refer to "Replacement Parts" inside the rear cover of this Manual. For prices, refer to the separate "Heath Parts Price List."

KEY No.	HEATH Part No.	QTY.	DESCRIPTION	CIRCUIT Comp. No.
---------	----------------	------	-------------	-------------------

### ELECTRONIC COMPONENTS

NOTE: 5% resistors have a gold fourth color band.

A1	6-271-12	8	270 $\Omega$ , 1/4-watt, 5% (red-viol-brn) resistor	R201, R202, R203, R204, R205, R206, R207, R208
A2	21-192	1	.1 $\mu$ F (104M) ceramic capacitor	C201
A3	411-861	4	7-segment display	V201, V202, V203, V204
A4	411-862	1	Bar display	V205

NOTE: Transistors may be marked for identification in any of the following four ways:

1. Part number.
2. Type number.
3. Part number and type number.

KEY No.	HEATH Part No.	QTY.	DESCRIPTION	CIRCUIT Comp. No.
---------	----------------	------	-------------	-------------------

4. Part number with a type number other than the one listed.

A5	417-865	4	MPSA55 transistor	Q201, Q202, Q203, Q204
----	---------	---	-------------------	------------------------

### MISCELLANEOUS

	85-2759-1	1	Display circuit board	
B1	490-185	1	Package of desoldering braid	
			Solder	

### PARTS FROM THE FINAL PACK

C1	390-2393	1	Identification label*	
C2		1	Blue and white label*	
C3	391-664	1	Nameplate*	
		1	Parts Order Form*	
		1	Assembly Manual (See Page 1 for the part number.)	

\* These items may be packed inside the Manual. Set them aside for use later.

## STEP-BY-STEP ASSEMBLY

**START** →

In the following steps, you will be given detailed instructions on how to install and solder the first part on the circuit board. Read and perform each step carefully. Then use the same procedure whenever you install parts on a circuit board.

- ( ) Position the circuit board as shown with the printed side (not the foil side) up. The circuit boards in this kit have foils on both sides. When you are instructed to solder a connection in a step, always solder to the foil on the back (not the printed) side.

**NOTE:** When you install a component that has its value printed on it, position the value marking up, so it can be easily read. Diodes should be mounted with their types or part number up, if possible.

- ( ) Hold a 270  $\Omega$  (red-viol-brn) resistor with long-nose pliers and bend the leads straight down to fit the hole spacing on the circuit board.

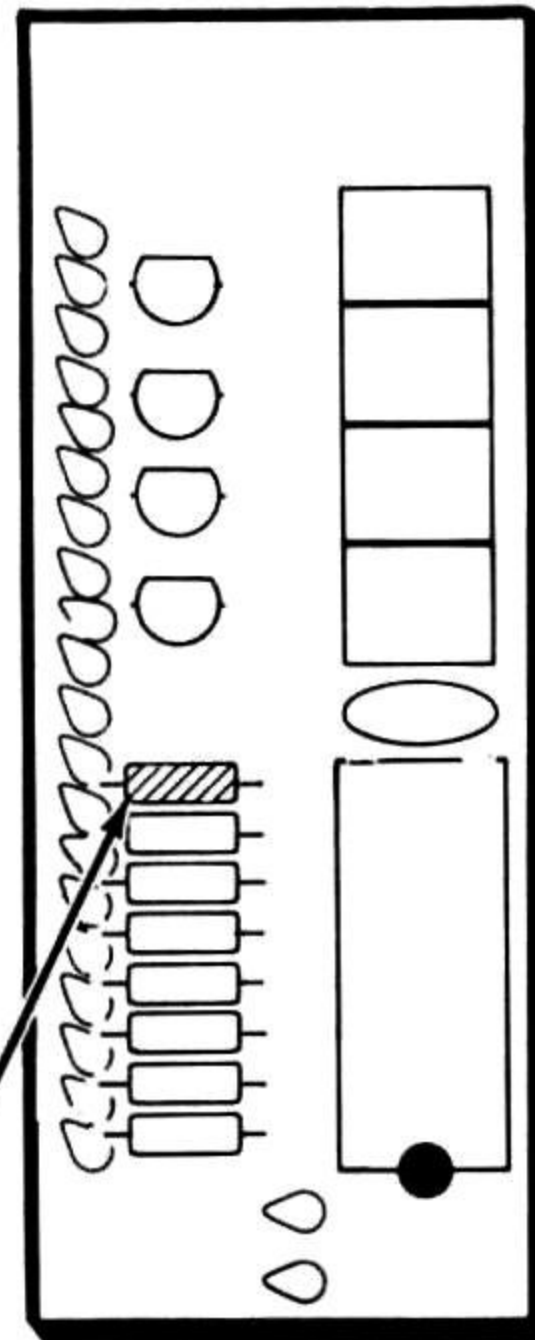

PICTORIAL 1-1

- ( ) R208: Push the leads through the holes at the indicated location on the circuit board. The end with color bands may be positioned either way.

- ( ) Press the resistor against the circuit board. Then bend the leads outward slightly to hold the resistor in place.

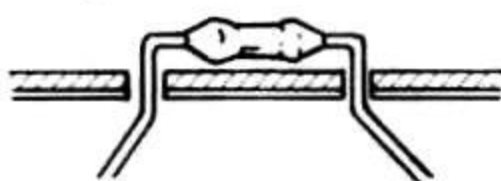
**CONTINUE** →

- ( ) Turn the circuit board over and solder the resistor leads to the foil as follows:

1. Push the soldering iron tip against both the lead and the circuit board foil. Heat **both** for two or three seconds.

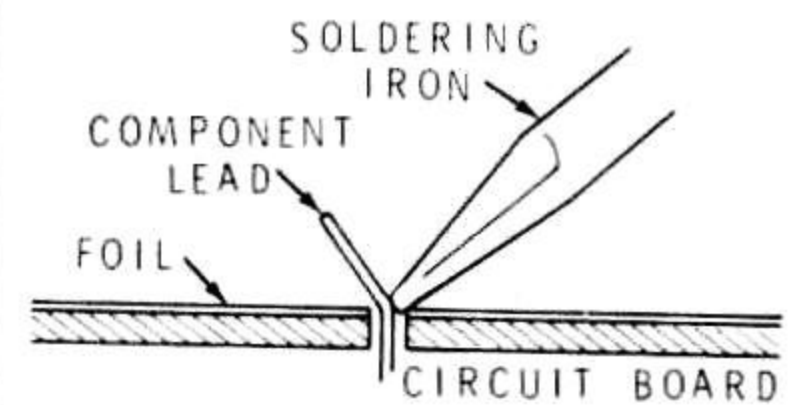

2. Then apply solder to the other side of the connection. **IMPORTANT:** Let the heated lead and the circuit board foil melt the solder.

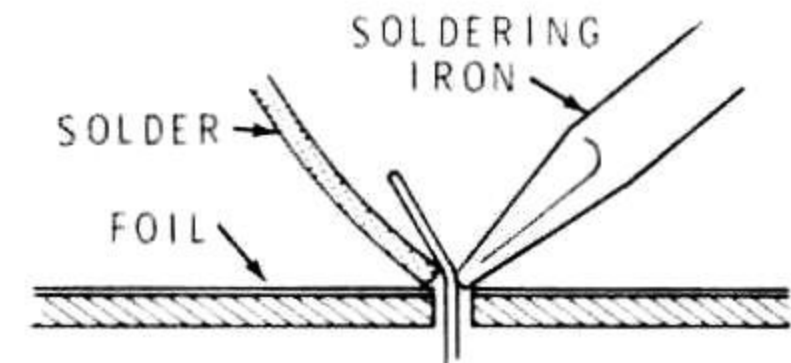

3. As the solder begins to melt, allow it to flow around the connection. Then remove the solder and the iron and let the connection cool.

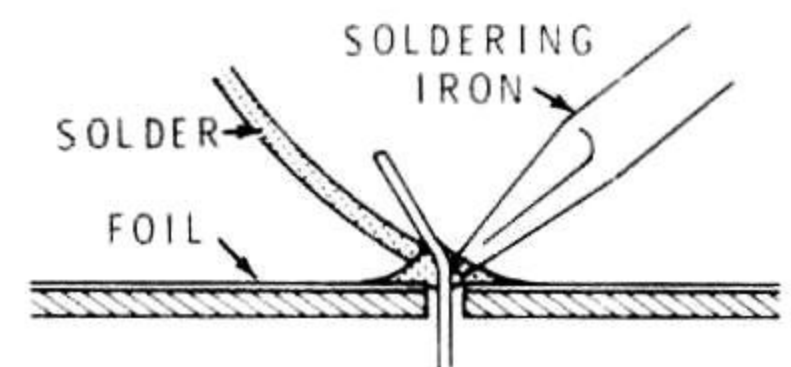

- ( ) Cut off the excess lead lengths close to the connection. **WARNING:** Clip the leads so the ends will not fly toward your eyes.

- ( ) Check each connection. Compare it to the illustrations on Page 11. After you have checked the solder connections, proceed with the assembly on Page 12. Use the same soldering procedure for each connection.

**A GOOD SOLDER CONNECTION**

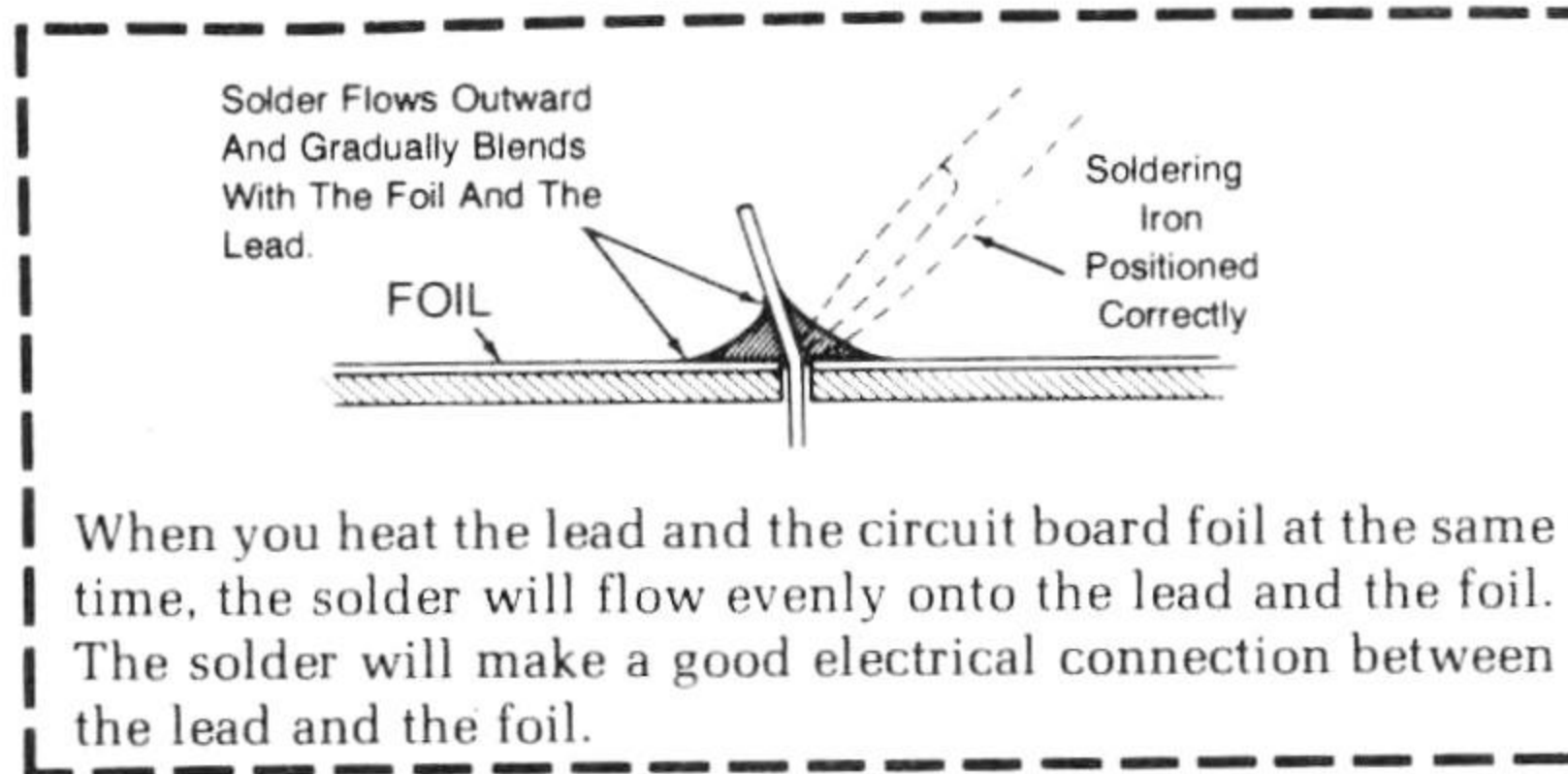

**POOR SOLDER CONNECTIONS**

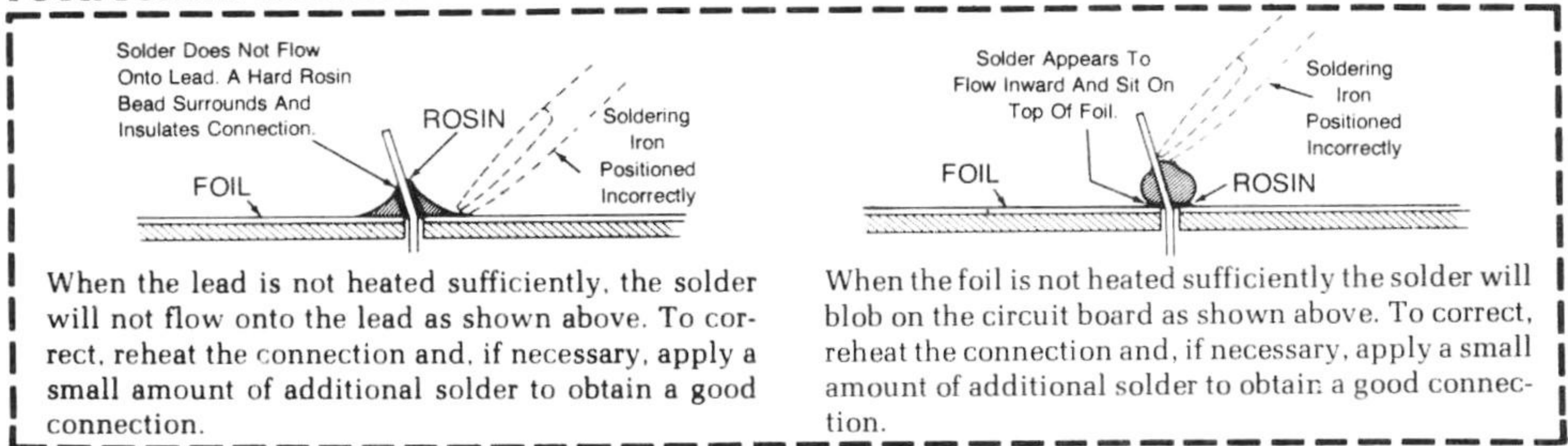

**SOLDER BRIDGES**

A solder bridge between two adjacent foils is shown in photograph A. Photograph B shows how the connection should appear. A solder bridge may occur if you accidentally touch an adjacent previously soldered connection, if you use too much solder, or if you "drag" the soldering iron across other foils as you remove it from the connection. A good rule to follow is: always take a good look at the foil area around each lead before you solder it. Then, when you solder the connection, make sure the solder remains in this area and does not bridge to another foil. This is especially important when the foils are small and close together. NOTE: It is alright for solder to bridge two connections on the same foil.

Use only enough solder to make a good connection, and lift the soldering iron straight up from the circuit board. If a solder bridge should develop, turn the circuit board foil-side-down and heat the solder between connections. The excess solder will run onto the tip of the soldering iron, and this will remove the solder bridge. NOTE: The foil side of most circuit boards has a coating on it called "solder resist." This is a protective insulation to help prevent solder bridges.

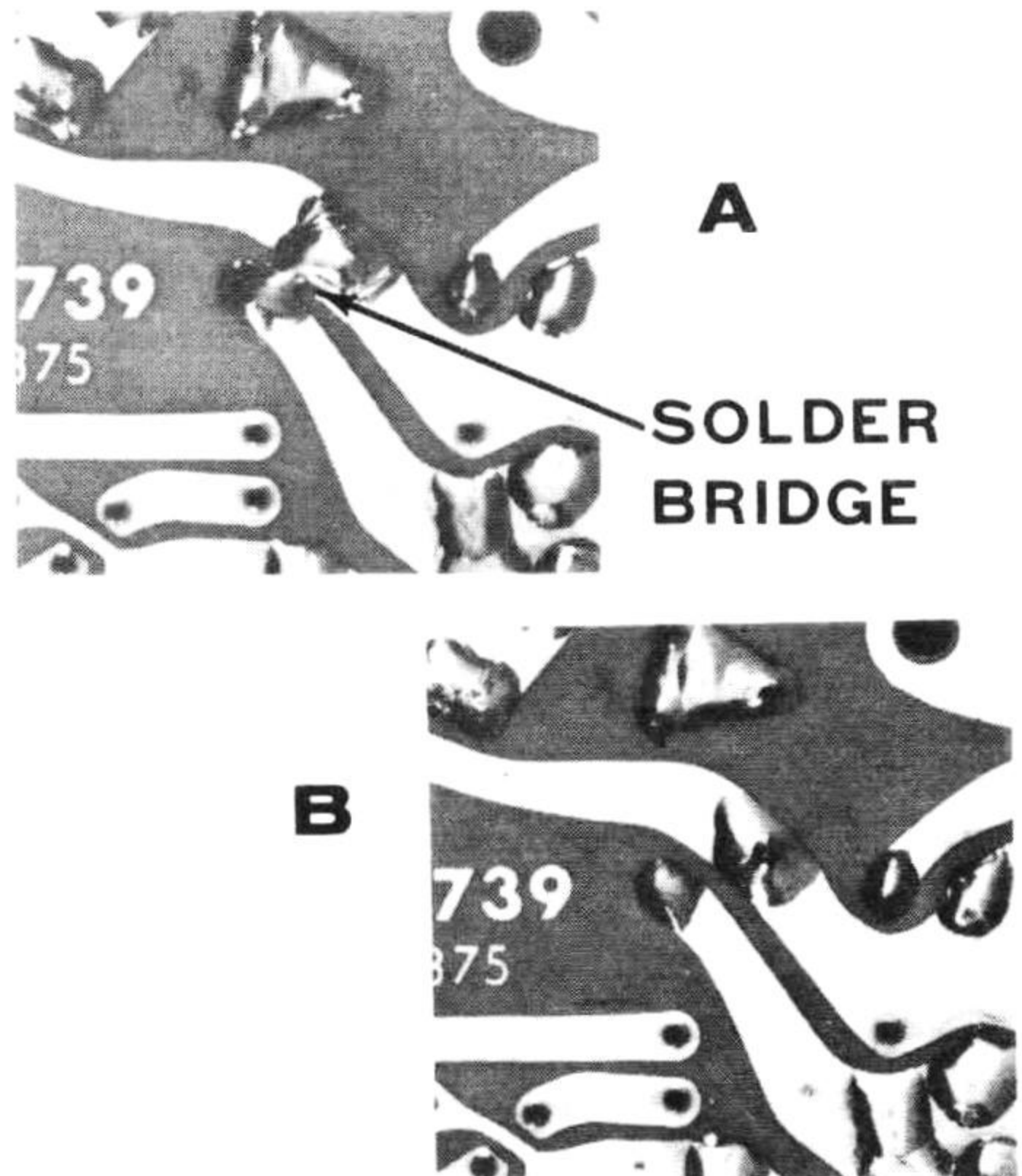

**START** →

( ) Be sure you installed resistor R208 in Pictorial 1-1.

Install seven 270 Ω (red-viol-brn) resistors at the following locations:

- ( ) R207 .....
- ( ) R206 .....
- ( ) R205 .....
- ( ) R204 .....
- ( ) R203 .....
- ( ) R202 .....
- ( ) R201 .....

( ) C201: .1 μF (104M) ceramic.

( ) Solder the leads to the foil and cut off the excess lead lengths.

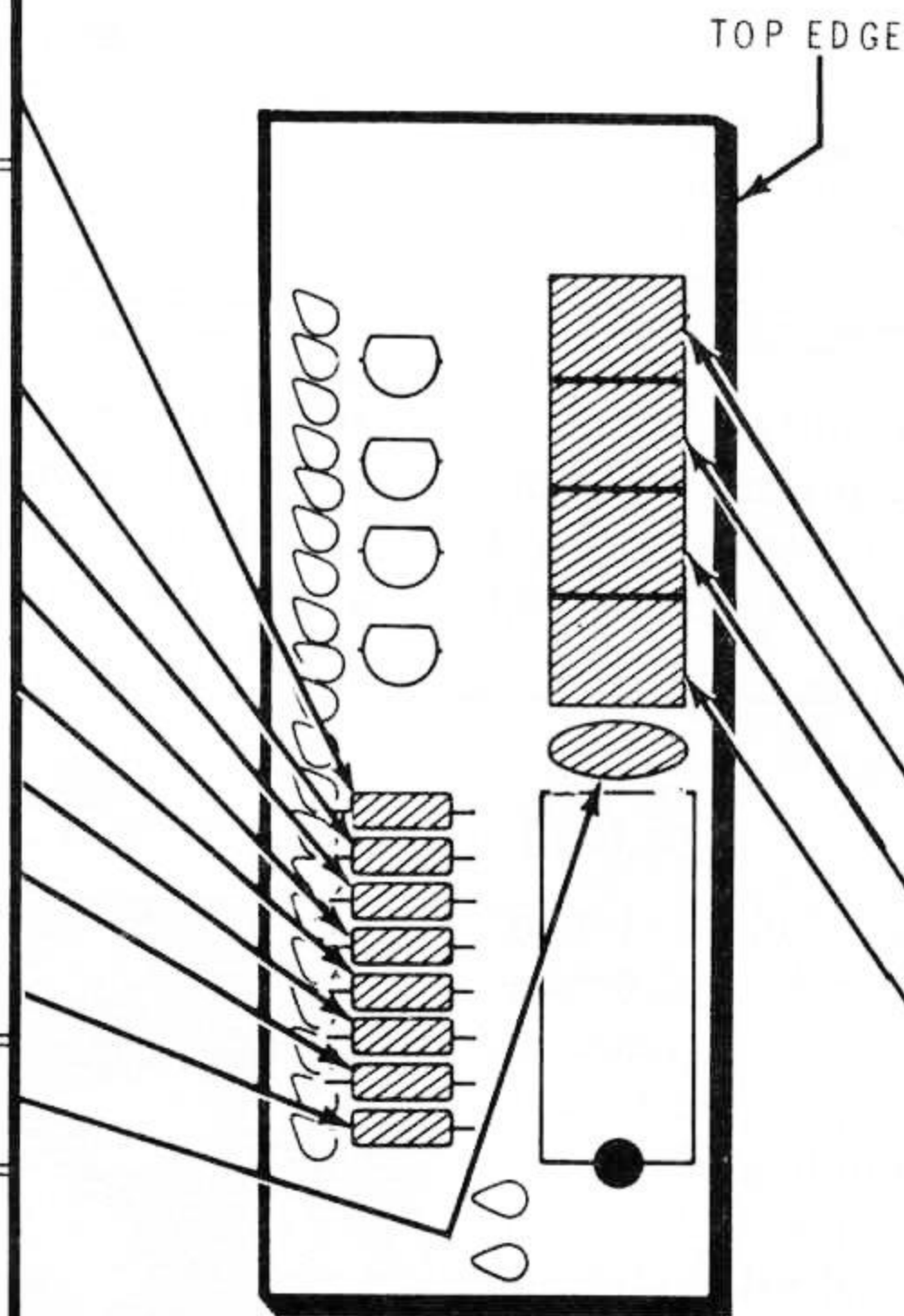

**CONTINUE** →

NOTE: When you install a 7-segment display, position it over its outline on the circuit board so the dot is nearest the top edge of the circuit board. Start the leads into their circuit board holes and press the display tight against the circuit board. Then solder the leads to the foil and cut off any excess lead lengths.

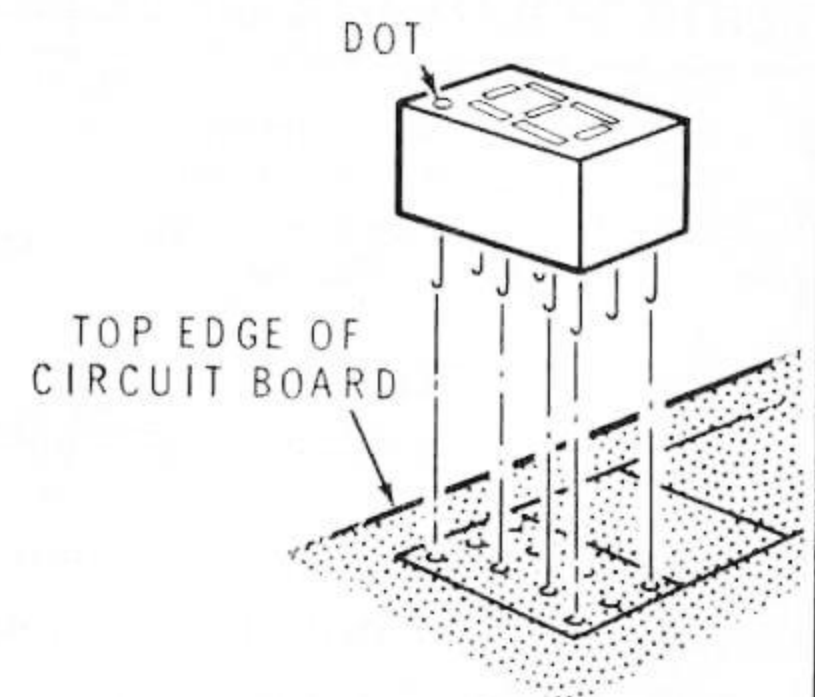

Install four 7-segment displays (#411-861) at the following locations:

- ( ) V201.
- ( ) V202.
- ( ) V203.
- ( ) V204.

PICTORIAL 1-2

**START** ↩

NOTE: When you install the bar display, position it over its outline on the circuit board so its color dot is aligned with the pin 1 hole in the circuit board. Start the pins into their holes, press the display tight against the circuit board, and solder the pins to the foil. Then cut off any excess pin lengths.

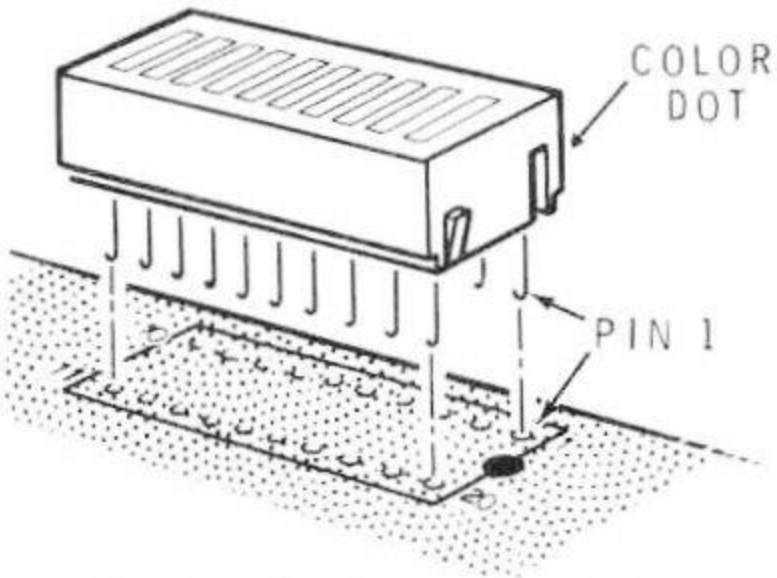

V205: Bar display (#411-862).

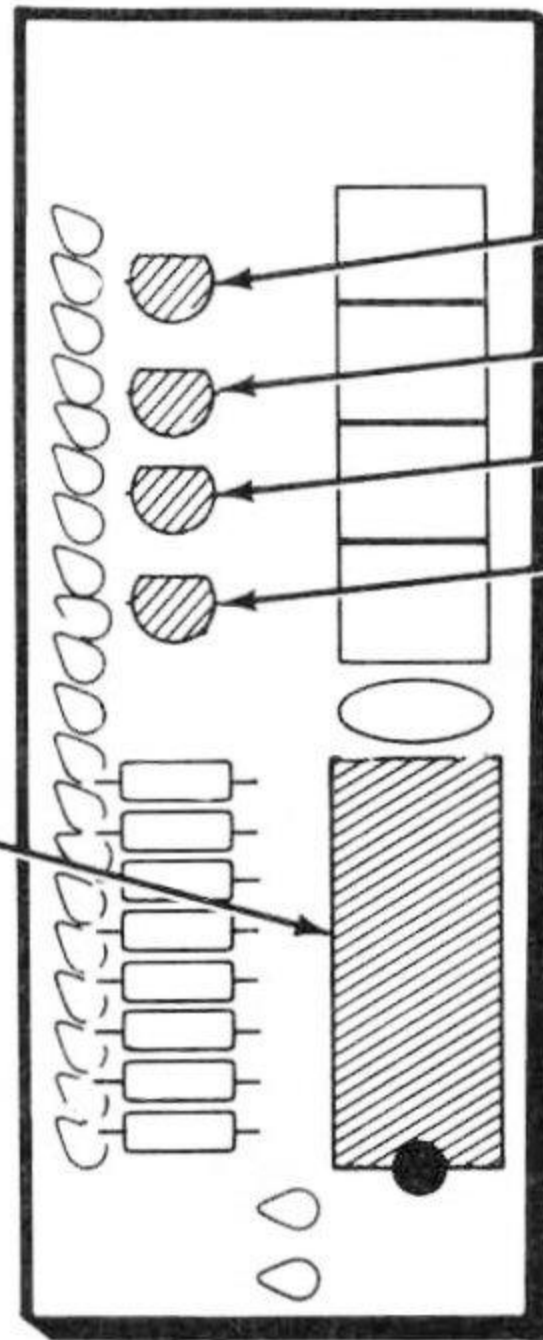

PICTORIAL 1-3

**CONTINUE** ↪

NOTE: When you install a transistor in each of the following steps, align its flat with the flat on the board. Insert the leads into their correct holes. Position the transistor 1/8" above the board. Then solder the leads to the foil and cut off the excess lead lengths.

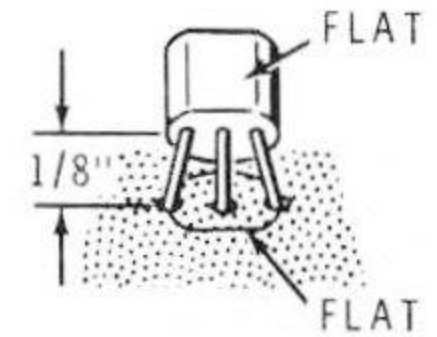

Install four MPSA55 transistors (#417-865) at the following locations:

- Q201.
- Q202.
- Q203.
- Q204.

**CIRCUIT BOARD CHECKOUT**

Carefully inspect the circuit board for the following conditions:

- Unsoldered connections.
- Poor solder connections.
- Solder bridges between foil patterns.
- Protruding leads which could touch together.
- Transistors for the proper installation.

Set the circuit board aside until it is called for. Proceed to "Main Circuit Board."





# MAIN CIRCUIT BOARD

## PARTS LIST

Refer to the Pack Index Sheet and locate Pack #2. Then remove the parts from this pack and check each part against the following list. The key numbers correspond to the numbers on the "Main Circuit Board Parts Pictorial" (Illustration Booklet, Page 2). Return any part that is packed in an individual envelope, with the part number on it, back into its envelope until that part is called for in a step. Do not throw away any packing material until you account for all the parts.

To order a replacement part, always include the PART NUMBER. Use the Parts Order Form furnished with this kit. If a Parts Order Form is not available, refer to "Replacement Parts" inside the rear cover of this Manual. For prices, refer to the separate "Heath Parts Price List."

KEY No.	HEATH Part No.	QTY.	DESCRIPTION	CIRCUIT Comp. No.
---------	----------------	------	-------------	-------------------

### RESISTORS

#### NOTES:

- The following resistors are rated at 1/4-watt and have a tolerance of 5% (gold fourth color band).
- The resistors may be packed in more than one envelope. Open all of the resistor envelopes in this pack before you check them against the Parts List.

A1	6-330-12	8	33 $\Omega$ (org-org-blk)	R9, R11, R12, R13, R14, R15, R16, R17
----	----------	---	---------------------------	--

KEY No.	HEATH Part No.	QTY.	DESCRIPTION	CIRCUIT Comp. No.
---------	----------------	------	-------------	-------------------

### Resistors (cont'd.)

A1	6-271-12	3	270 $\Omega$ (red-viol-brn)	R24, R25, R36
A1	6-102-12	2	1000 $\Omega$ (brn-blk-red)	R22, R32
A1	6-222-12	1	2200 $\Omega$ (red-red-red)	R29
A1	6-332-12	1	3300 $\Omega$ (org-org-red)	R28
A1	6-472-12	9	4700 $\Omega$ (yel-viol-red)	R1, R2, R3, R4, R5, R6, R7, R8, R23
A1	6-103-12	6	10 k $\Omega$ (brn-blk-org)	R18, R31, R33, R34, R35, R37
A1	6-183-12	1	18 k $\Omega$ (brn-gry-org)	R19
A1	6-104-12	2	100 k $\Omega$ (brn-blk-yel)	R26, R27

KEY No.	HEATH Part No.	QTY.	DESCRIPTION	CIRCUIT Comp. No.
---------	----------------	------	-------------	-------------------

**CAPACITORS**

B1	27-137	1	.02 $\mu$ F Mylar	C2
B2	21-143	9	.05 $\mu$ F ceramic	C7, C8, C9, C11, C12, C13, C14, C15, C16
C3	25-922	4	.68 $\mu$ F electrolytic	C6, C18, C19, C21
C3	25-924	1	2.2 $\mu$ F electrolytic	C17
C3	25-917	4	10 $\mu$ F electrolytic	C1, C3, C4, C22
C4	25-877	1	2200 $\mu$ F electrolytic	C5

**DIODES**

D1	56-26	8	1N191 (brn-wht-brn)	D2, D3, D4, D5, D6, D7, D8, D9
D1	56-56	5	1N4149	D1, D19, D21, D22, D24
D1	56-89	3	GD510	D13, D14, D23
D1	57-64	2	DRS110	D11, D12
D1	57-65	4	1N4002	D15, D16, D17, D18

**TRANSISTORS – INTEGRATED CIRCUITS (IC's)****NOTES:**

1. Transistors and integrated circuits may be marked for identification in any of the following four ways:
  - a. Part number.
  - b. Type number.

KEY No.	HEATH Part No.	QTY.	DESCRIPTION	CIRCUIT Comp. No.
---------	----------------	------	-------------	-------------------

**Transistors – Integrated Circuits (IC's) (Cont'd.)**

- c. Part number and type number (on integrated circuits, this refers only to the numbers; the letters may be different or missing).
- d. Part number with a type number other than the one listed.

2. Some integrated circuits may be packed in conductive foam. Do not remove these IC's from the conductive foam until a step directs you to do so.

E1	417-235	2	2N4121 transistor	Q12, Q18
E1	417-294	1	MPSA42 transistor	Q11
E1	417-801	2	MPSA20 transistor	Q9, Q17
E1	417-864	1	MPSA05 transistor	Q14
E1	417-865	10	MPSA55 transistor	Q1, Q2, Q3, Q4, Q5, Q6, Q7, Q8, Q15, Q16
E1	417-927	1	MPSA93 transistor	Q13
E1	442-627	1	78L05 IC	U11

**NOTE:** The following integrated circuits are in a bag marked "Parts 2 of 2 IC's." Keep these IC's in the bag until they are called for during the "Initial Tests."

E2	443-703	1	CD4001CN or MC14001CP IC	U9
E2	443-877	1	74LS138 IC	U7
E2	443-887	1	CD4023UBE IC	U6
E2	443-933	4	5101 IC	U2, U3, U4, U5
E2	443-1110	1	74LS377 IC	U8
E2	444-186	1	MK3870 IC	U1

KEY No.	HEATH Part No.	QTY.	DESCRIPTION	CIRCUIT Comp. No.	KEY No.	HEATH Part No.	QTY.	DESCRIPTION	CIRCUIT Comp. No.
<b>ELECTRONIC COMPONENTS</b>					<b>HARDWARE</b>				
F1	10-941	1	100 k $\Omega$ control	R21	H1	250-1172	2	2-56 $\times$ 1/4" screw	
F2	404-238	1	3579.545 kHz (3.579545 MHz) crystal	Y1	H2	250-1411	2	4-40 $\times$ 1/4" screw	
F3	418-37	3	1.5-volt battery	B1, B2, B3	H3	252-2	2	4-40 nut	
<b>SOCKETS – PLUGS – CONNECTORS</b>					<b>MISCELLANEOUS</b>				
G1	432-866	4	Spring connector (includes 1 extra)	P1, P2	J1	73-147	1	Foam tape	
G2	432-965	1	25-pin plug		J2	75-108	1	Insulator paper	
G3	432-1080	1	3-pin socket shell			85-2758-2	1	Main circuit board	
G4	434-253	1	40-pin IC socket		J3	258-5	2	Battery contact	
G4	434-298	2	14-pin IC socket			346-1	6"	Sleeving	
G4	434-299	1	16-pin IC socket			347-55	6'	8-wire cable	
G4	434-311	1	20-pin IC socket		J4	354-6	1	Cable tie	
G4	434-339	4	22-pin IC socket						

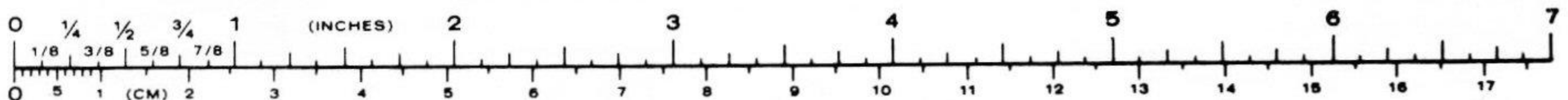

# STEP-BY-STEP ASSEMBLY

## START

( ) Position the circuit board as shown with the printed side (not the foil side) up.

NOTE: Only a portion of the circuit board is shown in some of the following Pictorials. The small "Identification Drawing" at the top of the page shows the area of the circuit board to be assembled.

( ) R29: 2200 Ω (red-red-red).

( ) R31: 10 kΩ (brn-blk-org).

NOTE: When you install a diode, always match the band on the diode with the band mark on the circuit board. A DIODE WILL NOT WORK PROPERLY IF IT IS INSTALLED BACKWARDS. See Detail 2-1A.

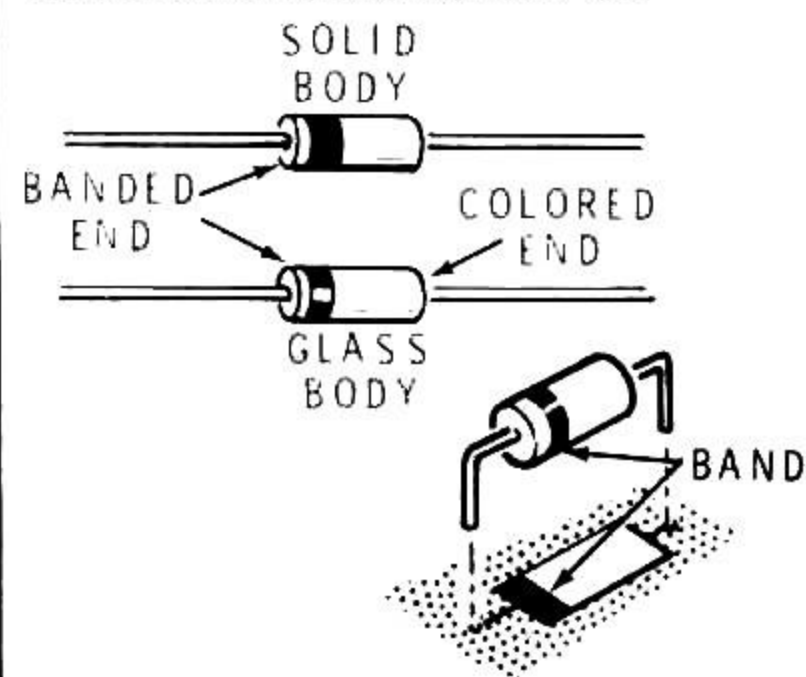

If your diode has a solid body, the band is clearly defined. If your diode has a glass body, do not mistake the colored end inside the diode for the banded end. Look for a band painted on the outside of the glass.

( ) D23: GD510 diode (#56-89).

( ) D11: DRS110 diode (#57-64).

( ) D1: 1N4149 diode (#56-56).

( ) D3: 1N191 diode (#56-26, brn-wht-brn).

( ) D4: 1N191 diode (#56-26, brn-wht-brn).

( ) D5: 1N191 diode (#56-26, brn-wht-brn).

( ) Solder the leads to the foil and cut off the excess lead lengths.

The steps performed in this Pictorial are in this area of the circuit board.

PART NUMBER

IDENTIFICATION DRAWING

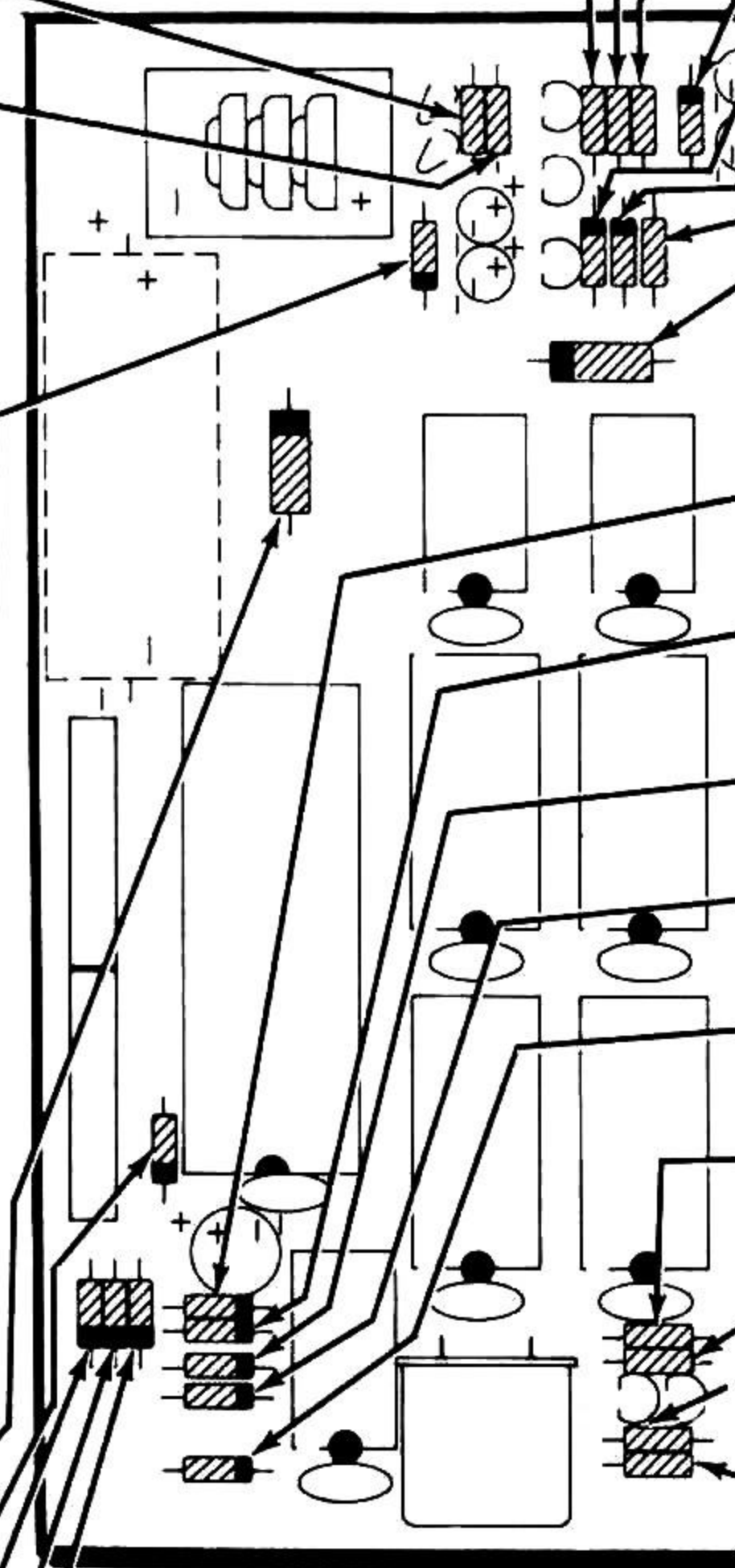

PICTORIAL 2-1

## CONTINUE

( ) R32: 1000 Ω (brn-blk-red).

( ) R34: 10 kΩ (brn-blk-org).

( ) R33: 10 kΩ (brn-blk-org).

( ) D19: 1N4149 diode (#56-56).

( ) D22: 1N4149 diode (#56-56).

( ) D21: 1N4149 diode (#56-56).

( ) R35: 10 kΩ (brn-blk-org).

( ) D12: DRS110 diode (#57-64).

( ) Solder the leads to the foil and cut off the excess lead lengths.

( ) D9: 1N191 diode (#56-26, brn-wht-brn)

( ) D8: 1N191 diode (#56-26, brn-wht-brn).

( ) D7: 1N191 diode (#56-26, brn-wht-brn).

( ) D6: 1N191 diode (#56-26, brn-wht-brn).

( ) D2: 1N191 diode (#56-26, brn-wht-brn).

( ) R7: 4700 Ω (yel-viol-red).

( ) R16: 33 Ω (org-org-blk).

( ) R8: 4700 Ω (yel-viol-red).

( ) R17: 33 Ω (org-org-blk).

( ) Solder the leads to the foil and cut off the excess lead lengths.

IMPORTANT: THE BANDED END OF DIODES CAN BE MARKED IN A NUMBER OF WAYS.

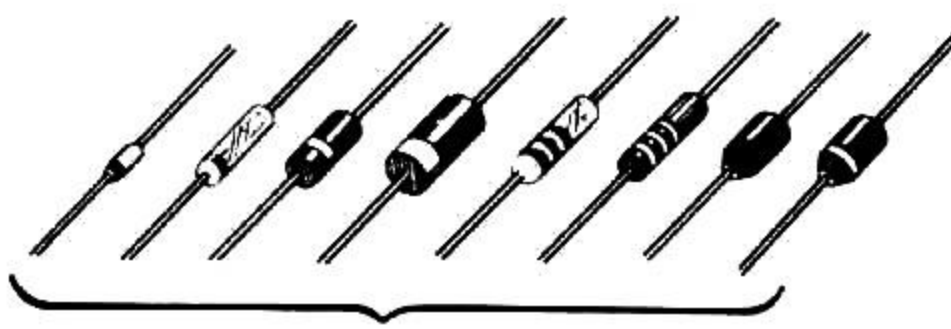

BANDED END (CATHODE)

Detail 2-1A

The steps performed in this Pictorial are in this area of the circuit board.

PART NUMBER

IDENTIFICATION DRAWING

## CONTINUE

NOTE: Be sure to install the following diodes so their bands are positioned as shown on the circuit board.

Install four 1N4002 diodes (#57-65) at the following locations:

- ( ) D18.
- ( ) D17.
- ( ) D15.
- ( ) D16.

( ) R22: 1000  $\Omega$  (brn-blk-red).

( ) D24: 1N4149 diode (#56-56).

( ) Solder the leads to the foil and cut off the excess lead lengths.

( ) D14: GD510 diode (#56-89).

( ) D13: GD510 diode (#56-89).

( ) R36: 270  $\Omega$  (red-viol-brn).

( ) R19: 18 k $\Omega$  (brn-gry-org).

( ) R27: 100 k $\Omega$  (brn-blk-yel).

( ) R28: 3300  $\Omega$  (org-org-red).

( ) R26: 100 k $\Omega$  (brn-blk-yel).

( ) R23: 4700  $\Omega$  (yel-viol-red).

( ) R24: 270  $\Omega$  (red-viol-brn).

( ) Solder the leads to the foil and cut off the excess lead lengths.

## START

( ) R37: 10 k $\Omega$  (brn-blk-org).

( ) R18: 10 k $\Omega$  (brn-blk-org).

( ) R25: 270  $\Omega$  (red-viol-brn).

( ) R1: 4700  $\Omega$  (yel-viol-red).

( ) R9: 33  $\Omega$  (org-org-blk).

( ) R2: 4700  $\Omega$  (yel-viol-red).

( ) R11: 33  $\Omega$  (org-org-blk).

( ) Solder the leads to the foil and cut off the excess lead lengths.

( ) R3: 4700  $\Omega$  (yel-viol-red).

( ) R12: 33  $\Omega$  (org-org-blk).

( ) R4: 4700  $\Omega$  (yel-viol-red).

( ) R13: 33  $\Omega$  (org-org-blk).

( ) R5: 4700  $\Omega$  (yel-viol-red).

( ) R14: 33  $\Omega$  (org-org-blk).

( ) R6: 4700  $\Omega$  (yel-viol-red).

( ) R15: 33  $\Omega$  (org-org-blk).

( ) Solder the leads to the foil and cut off the excess lead lengths.

PICTORIAL 2-2

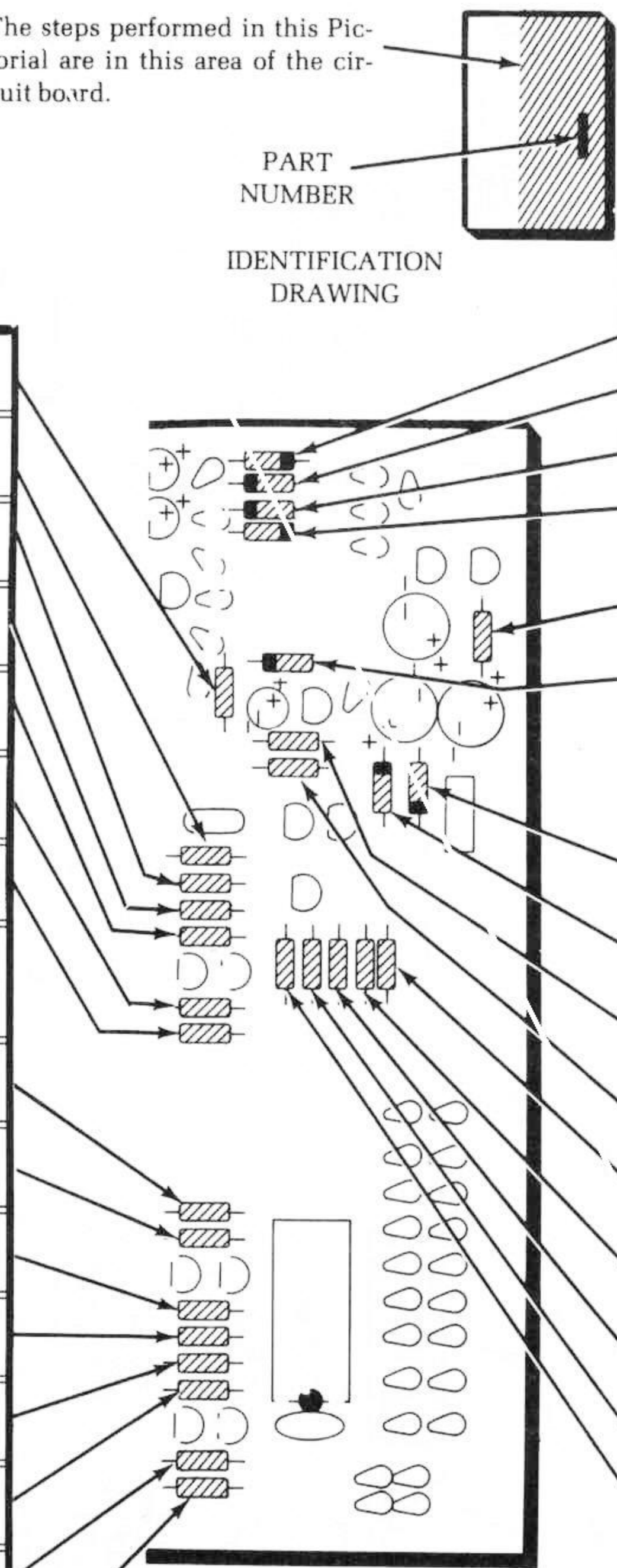

**START** →

NOTE: When you install an IC socket, be sure the index mark is still visible after the socket is installed. Then solder the pins to the foil.

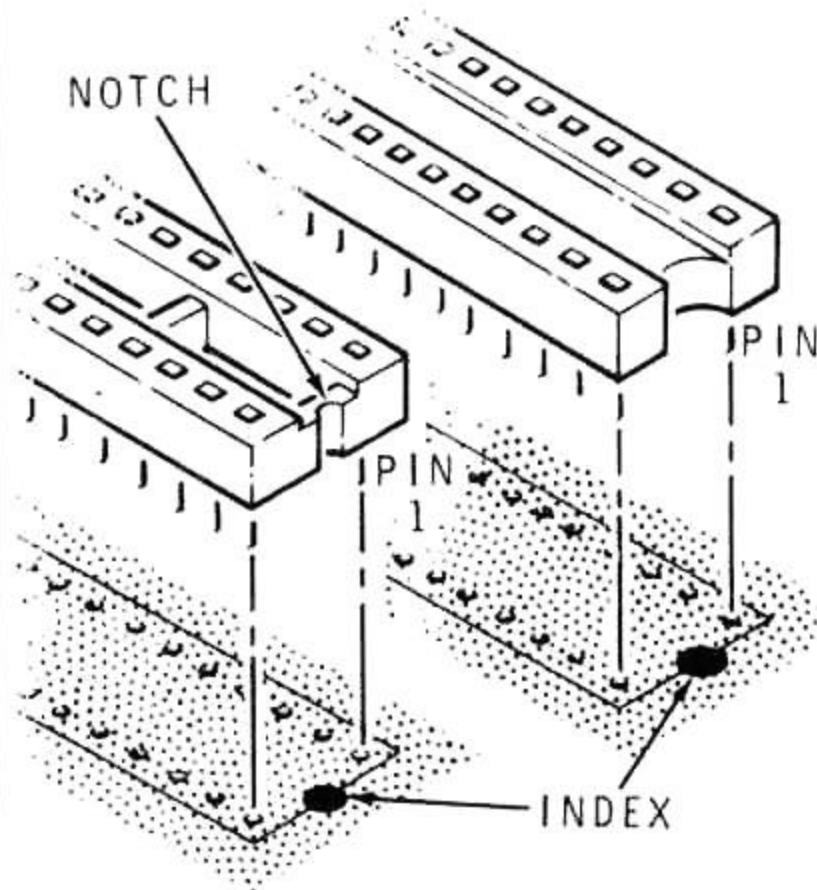

- ( ) Install 22-pin IC sockets at locations U2, U3, U4, and U5.
- ( ) Install a 20-pin IC socket at location U8.
- ( ) Install a 16-pin IC socket at location U7.
- ( ) Install 14-pin IC sockets at locations U6 and U9.
- ( ) Install the 40-pin IC socket at location U1.
- ( ) Refer to Detail 2-3A and cut two 10-pin plugs from the 25-pin plug. Cut the 25-pin plug at pin 11 from each end. Discard the cut-off center section.
- ( ) Refer to Detail 2-3B and insert the short end of the pins of a 10-pin plug into the circuit board at location P2 and solder the pins to the foil. Keep the plug tight against the board.
- ( ) Remove pin 9 from the other 10-pin plug. Then install this plug at location P1 on the circuit board.

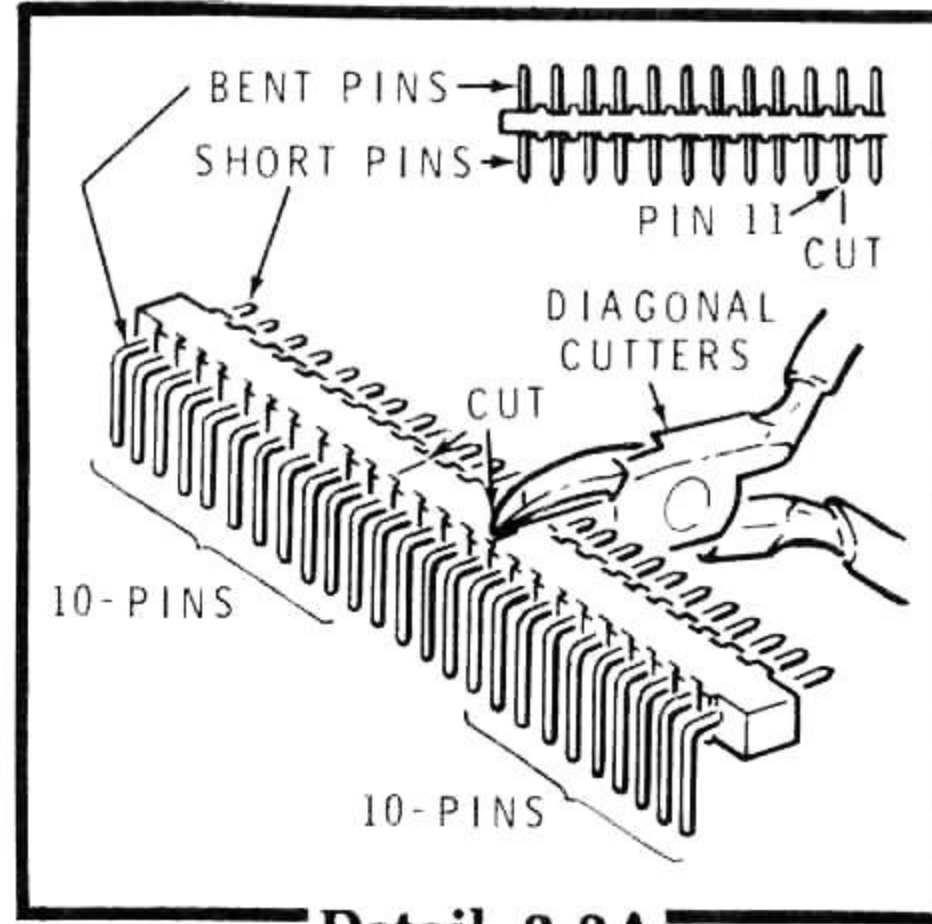

Detail 2-3A

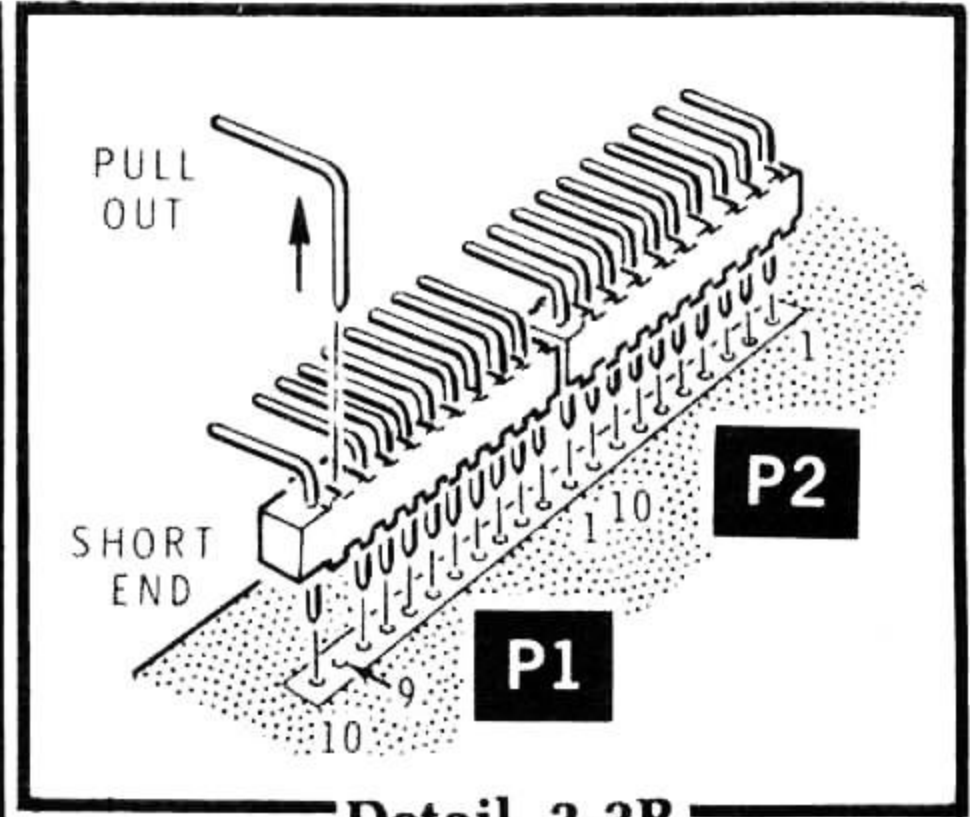

Detail 2-3B

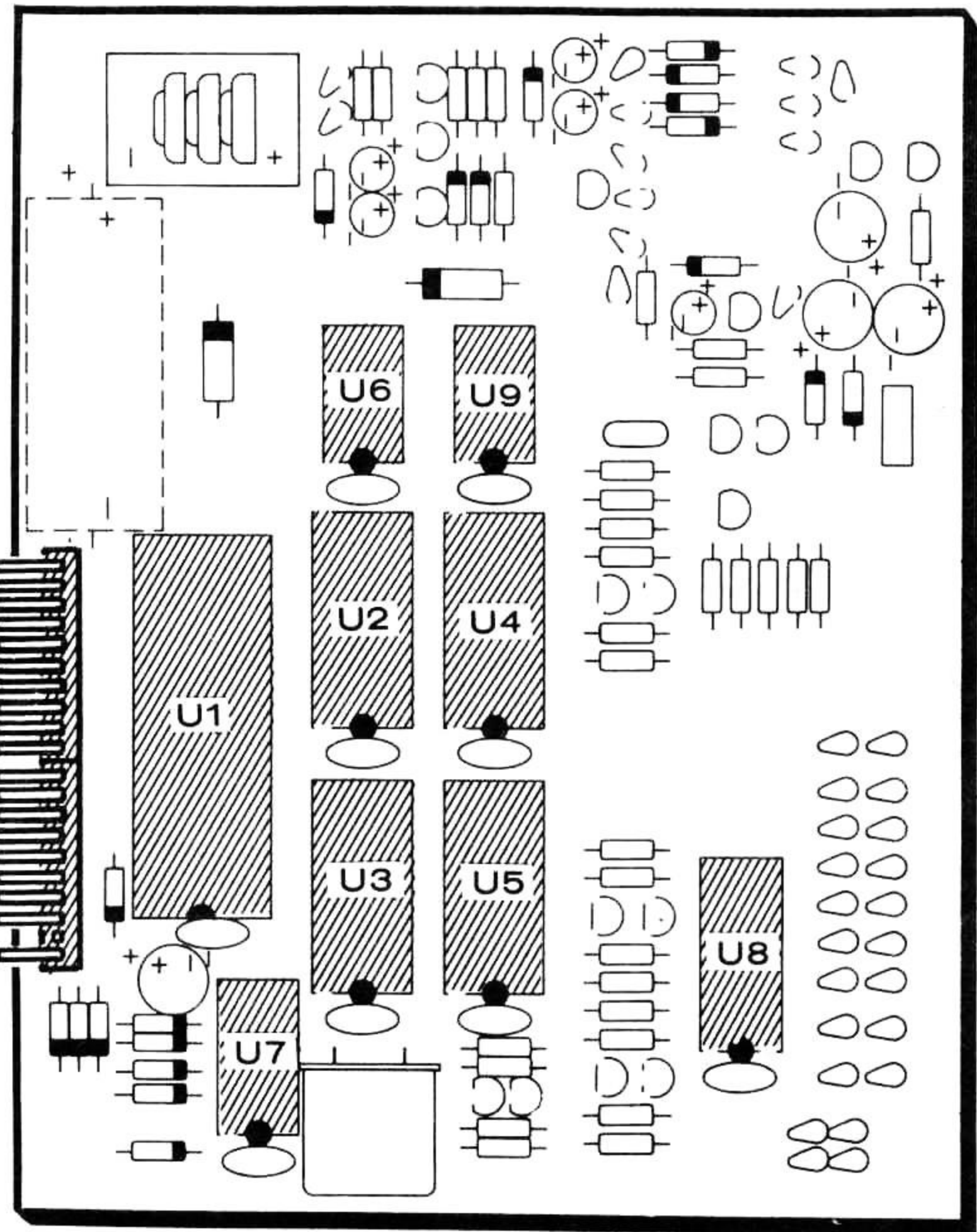

PICTORIAL 2-3

**START** 

NOTE: When you install a transistor or IC in this Pictorial, align its flat with the flat on the board. Start the leads into their corresponding holes. Position it 1/4" above the board and solder the leads to the foil. Then cut off the excess lead lengths. See Detail 2-4A.

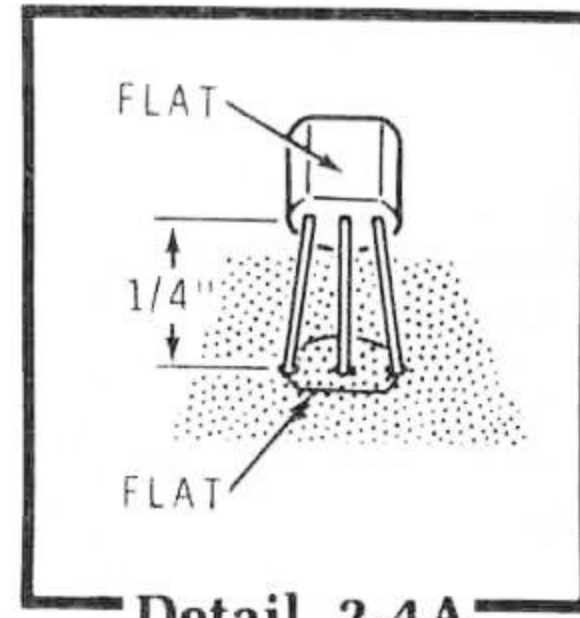

**Detail 2-4A**

( ) Q17: MPSA20 transistor (#417-801).

( ) Q18: 2N4121 transistor (#417-235).

( ) Q11: MPSA42 transistor (#417-294). Be careful not to use the hole that is outside the circuit board outline.

( ) U11: 78L05 IC (#442-627).

( ) Q14: MPSA05 transistor (#417-864).

( ) Q15: MPSA55 transistor (#417-865).

( ) Q16: MPSA55 transistor (#417-865).

( ) Q13: MPSA93 transistor (#417-927).

( ) Q12: 2N4121 transistor (#417-235).

( ) Q9: MPSA20 transistor (#417-801).

Install MPSA55 transistors (#417-865) at the following eight locations:

- ( ) Q1 .....
- ( ) Q2 .....
- ( ) Q3 .....
- ( ) Q4 .....
- ( ) Q7 .....
- ( ) Q8 .....
- ( ) Q5 .....
- ( ) Q6 .....

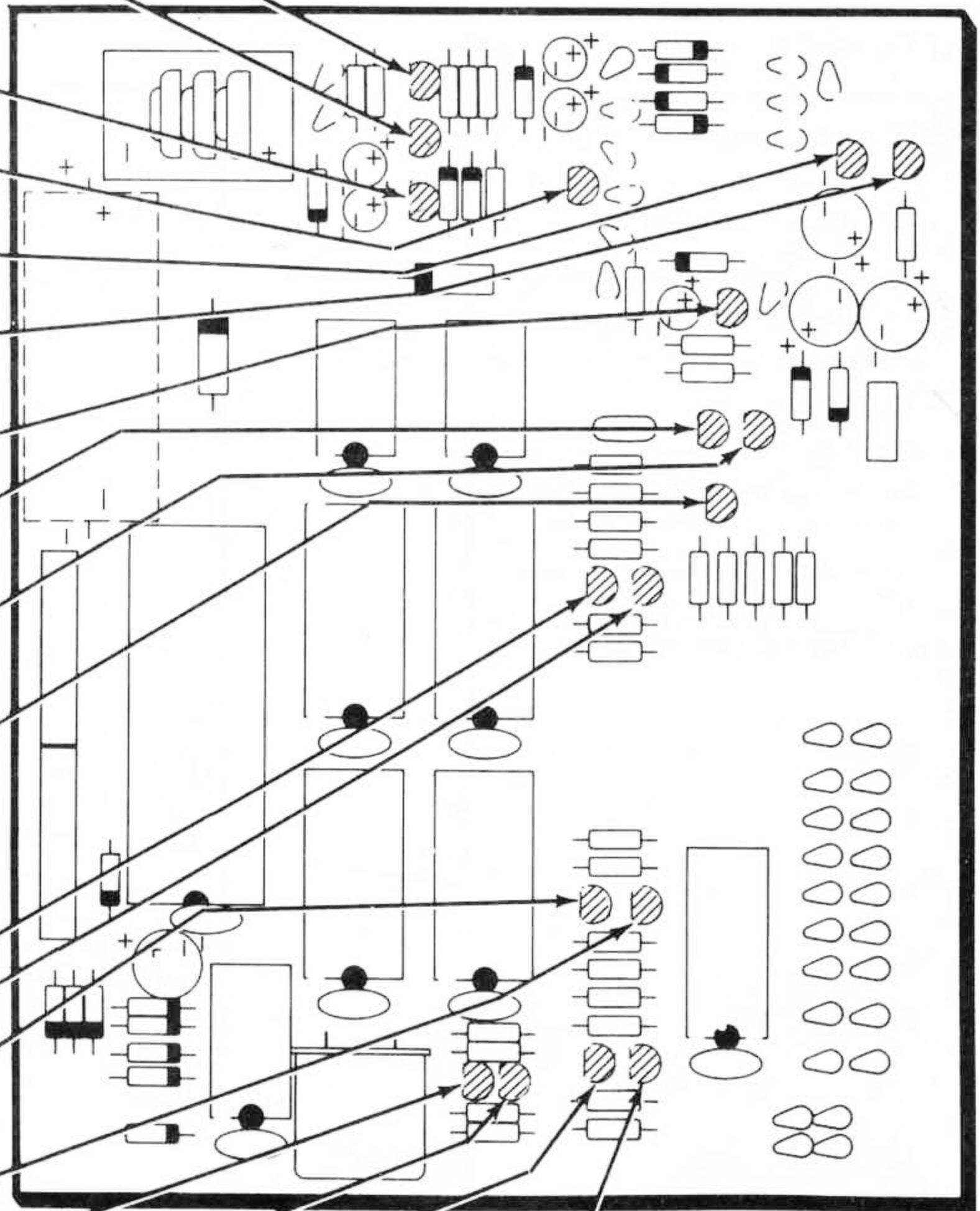

**PICTORIAL 2-4**

**START** 

- ( ) C21: .68  $\mu$ F electrolytic. See Detail 2-5A.
- ( ) C6: .68  $\mu$ F electrolytic.
- ( ) C17: 2.2  $\mu$ F electrolytic.
- ( ) C18: .68  $\mu$ F electrolytic.
- ( ) C3: 10  $\mu$ F electrolytic.
- ( ) C19: .68  $\mu$ F electrolytic.
- ( ) C22: 10  $\mu$ F electrolytic.
- ( ) C4: 10  $\mu$ F electrolytic.
- ( ) C2: .02  $\mu$ F Mylar.
- ( ) Solder the leads to the foil and cut off the excess lead lengths.
- Install .05  $\mu$ F ceramic capacitors at the following eight locations. See Detail 2-5B.
- ( ) C8 .....
- ( ) C7 .....
- ( ) C12 .....
- ( ) C14 .....
- ( ) C16 .....
- ( ) C15 .....
- ( ) C13 .....
- ( ) C9 .....
- ( ) C1: 10  $\mu$ F electrolytic.
- ( ) C11: .05  $\mu$ F ceramic.
- ( ) Solder the leads to the foil and cut off the excess lead lengths.

NOTE: When you install electrolytics, be sure to match the positive (+) mark on the capacitor with the positive (+) mark on the circuit board, or match the negative (-) mark on the capacitor with the negative (-) mark on the circuit board.

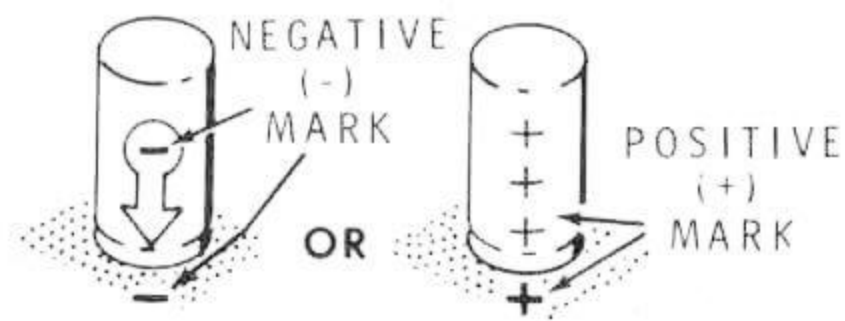

**Detail 2-5A**

NOTE: When you install ceramic capacitors, do not push the insulated portions of the leads into the circuit board holes. This could make it difficult to solder the leads to the foil.

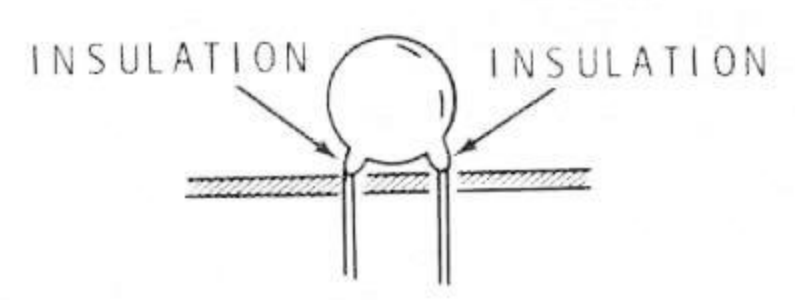

**Detail 2-5B**

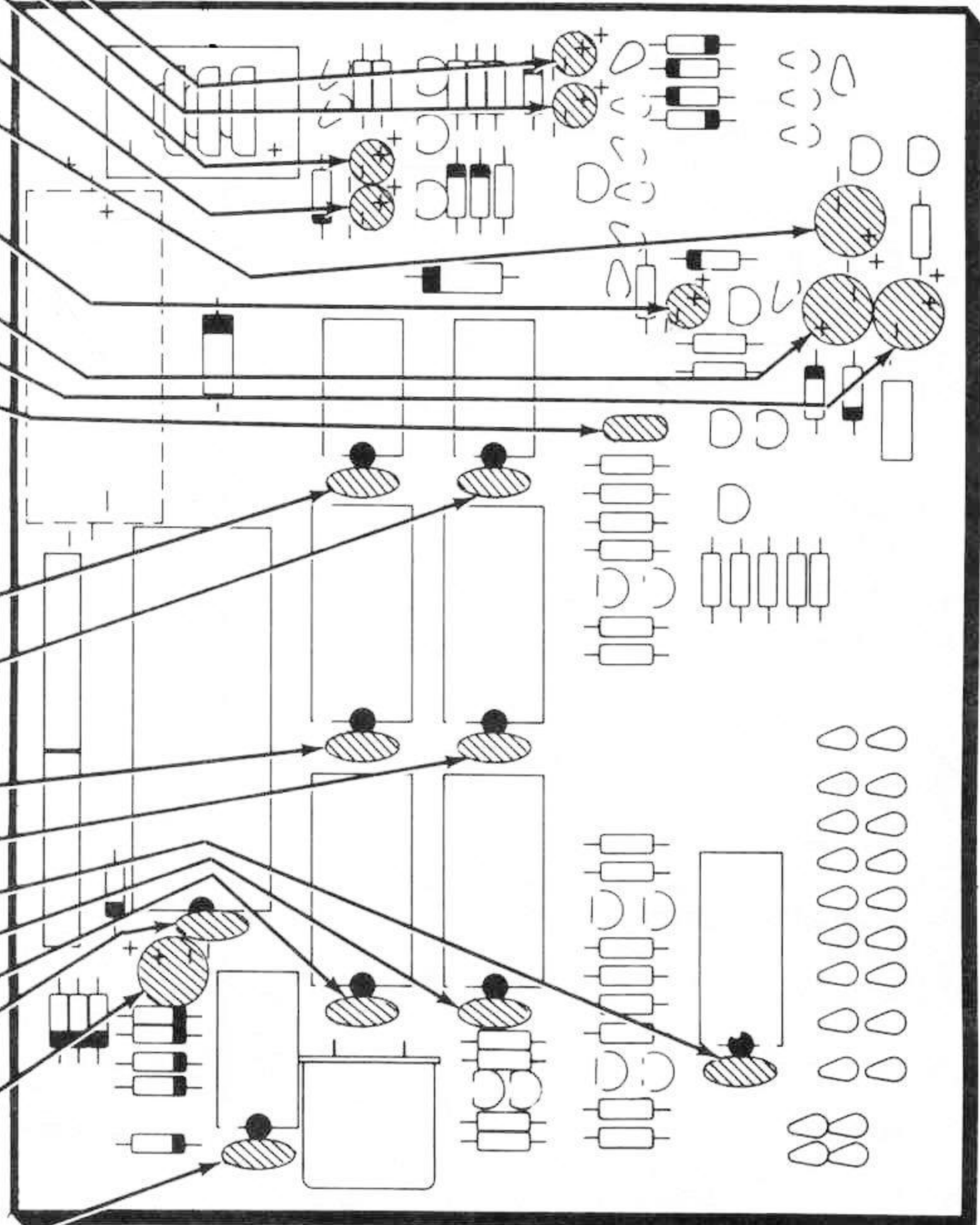

**PICTORIAL 2-5**



## START

- ( ) Mount the battery contacts at their holes in the circuit board. Use 2-56 × 1/4" screws, #2 lockwashers, and 2-56 nuts. Be sure to position the contacts as shown.

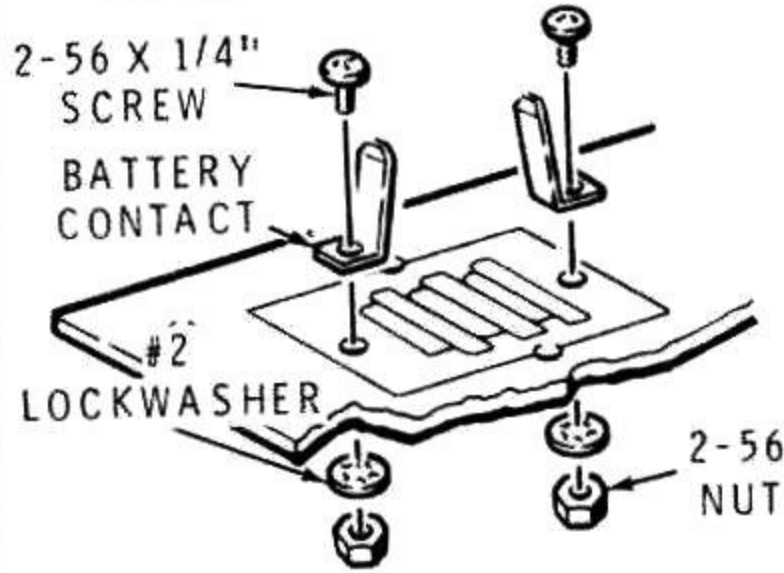

- ( ) C5: 2200 μF electrolytic. Place a 3/4" length of sleeving on each lead and bend the leads against the ends of the capacitor. Match the positive (+) mark on the capacitor with the positive (+) mark on the board or match the negative (-) mark on the capacitor with the negative (-) mark on the board. Insert the leads into their holes, solder the leads to the foil, and cut off the excess lead lengths.

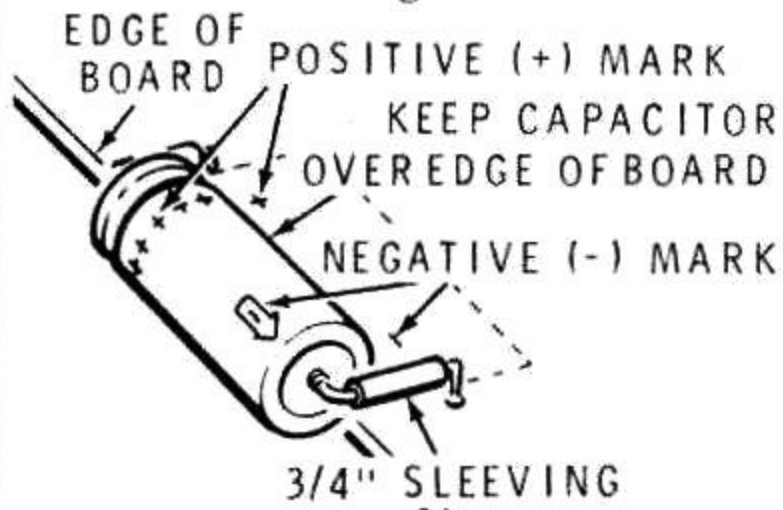

- ( ) R21: 100 kΩ control. Push the control tight against the board and solder the pins to the foil.

- ( ) Y1: 3579.545 kHz (3.579545 MHz) crystal (#404-238). Cut two 5/8" lengths of foam tape. Then remove the paper backing from one side of each piece and press the tape onto the crystal. See Detail 2-6A. Remove the paper backing from the other side of the foam tape, bend the crystal leads down, start the leads into their holes, and press the crystal onto the board. Solder the leads to the foil and cut off their excess lengths.

- ( ) Set the circuit board aside temporarily.

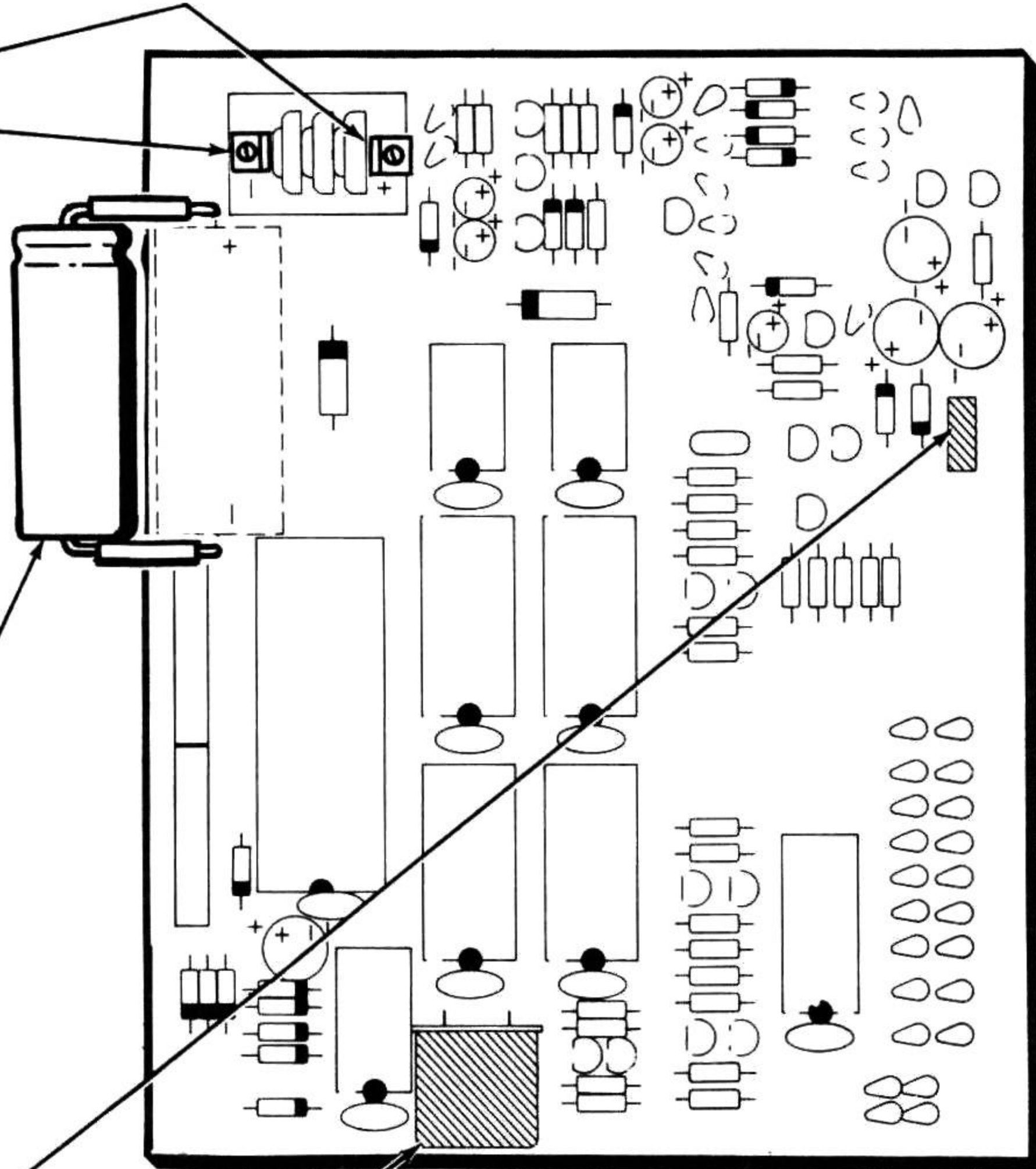

PICTORIAL 2-6

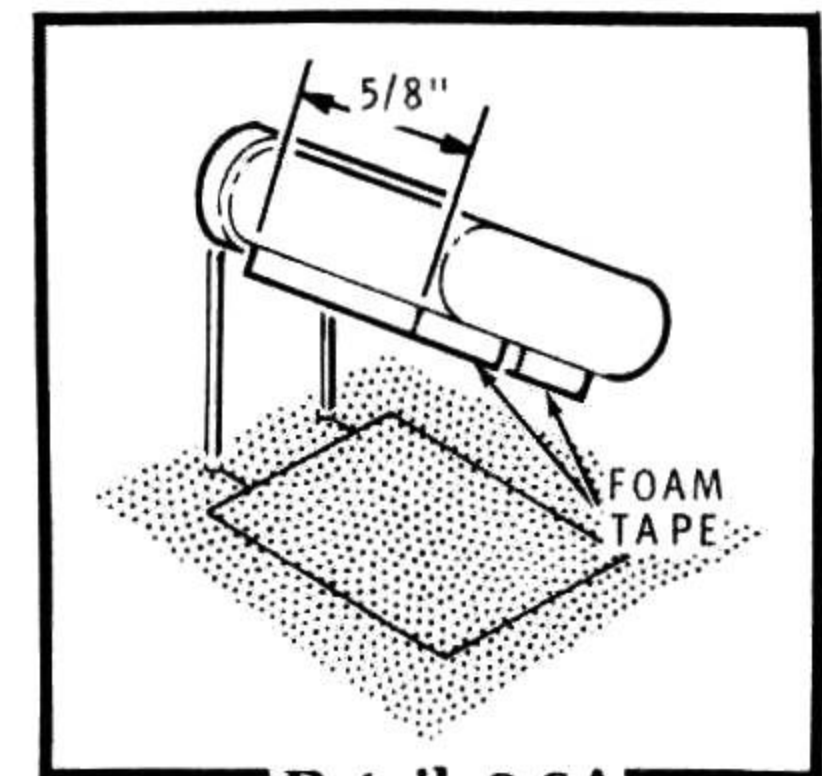

Detail 2-6A



(A) CUT THE 8-WIRE CABLE TO 7-1/4".

(B) SEPARATE THE WIRES AT THE ENDS APPROXIMATELY 1/4" USING A PAIR OF CUTTERS. TO DO THIS, FIRST LET THE SHARP EDGES OF THE CUTTER SEAT IN THE GROOVE BETWEEN THE WIRES, AND THEN CUT THEM APART JUST AT THE END. BE CAREFUL NOT TO CUT THE INSULATION AND EXPOSE THE INNER WIRES.

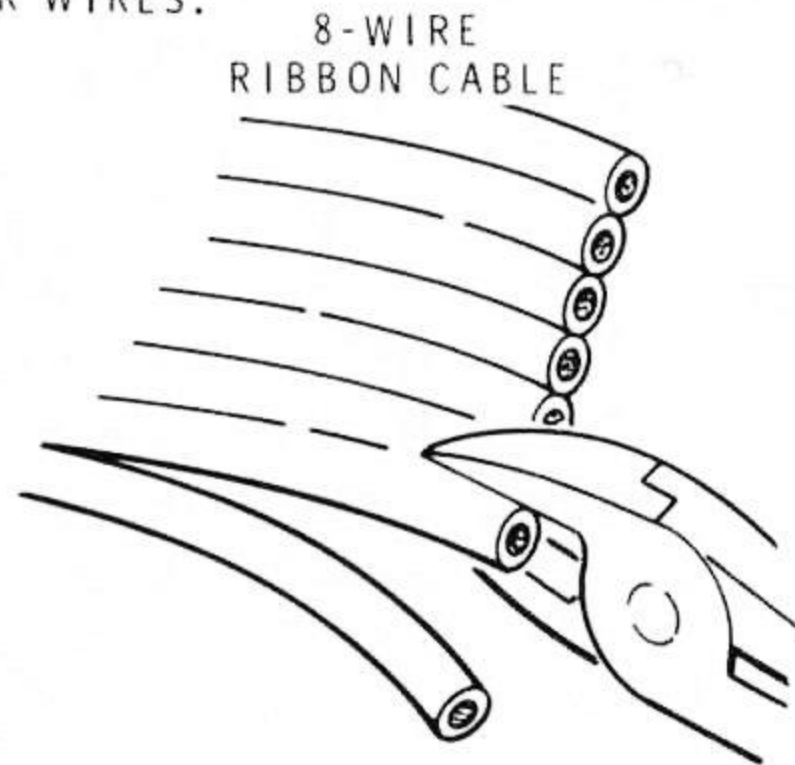

(C) SEPARATE THE 8-WIRE CABLE FOR ITS ENTIRE LENGTH BETWEEN THE GREEN AND YELLOW WIRES TO MAKE TWO 4-WIRE CABLES. DO THIS BY PULLING THE CABLE APART BY HAND. SAVE BOTH SECTIONS AS SOME OF THE WIRES WILL BE USED LATER.

(D) MARK THE 4-WIRE CABLE HAVING THE BROWN WIRE WITH INK AT THE TWO INDICATED LOCATIONS.

(E) SEPARATE THE INDICATED COLOR WIRES TO THE INDICATED INK MARKS. POSITION THE BROWN WIRE AS SHOWN.

(F) CUT THE SPECIFIED COLOR WIRES TO THE INDICATED LENGTHS FROM THE INK MARKS.

(G) REMOVE 1/4" OF INSULATION FROM THE END OF EACH WIRE.

(H) TWIST THE FINE STRANDS AND MELT A SMALL AMOUNT OF SOLDER ON THE EXPOSED WIRE ENDS.

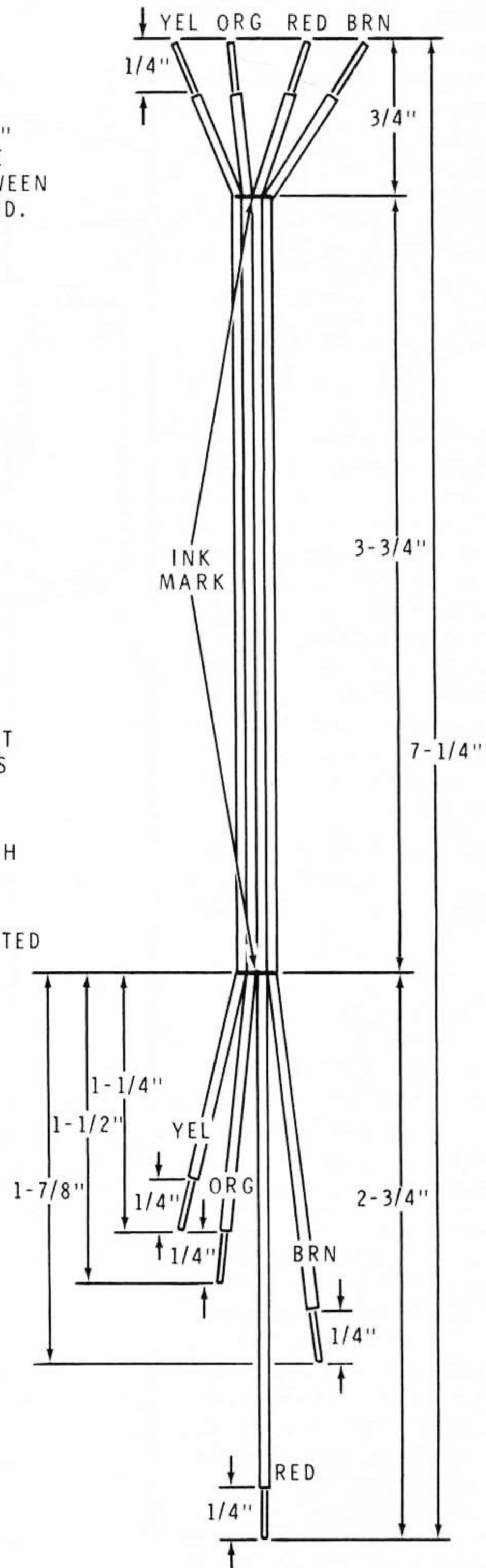

Detail 2-7A

Refer to Pictorial 2-7 (Illustration Booklet, Page 3) for the following steps.

- ( ) Refer to Detail 2-7A and prepare a 7-1/4" length of 8-wire cable. NOTE: The cable preparation details are full size, except as noted.

NOTE: When you solder a wire to the foil side of a circuit board, as in the next step, keep the insulation 1/8" above the circuit board to make sure you get a good solder connection. Refer to the inset drawing on the Pictorial.

- ( ) Solder the wires at the even end of this prepared 4-wire cable into the indicated holes in the display circuit board. Install the wires in the **foil** (not the printed) side of the circuit board. The hole letters are on the printed side of the circuit board. The yellow wire goes into hole "H."

- ( ) Refer to Detail 2-7B (Illustration Booklet, Page 3) and prepare a 7-1/4" length of 8-wire cable. Use the same procedure as you did earlier.

- ( ) Solder the wires at the even end of this 8-wire cable into the indicated holes in the display circuit board. The gray wire goes into hole "J."

- ( ) Refer to Detail 2-7C and prepare a 5-3/4" length of 8-wire cable.

- ( ) Solder the wires at the even end of this 8-wire cable into the indicated holes in the display circuit board. The gray wire goes into hole "X."

- ( ) Locate the 7-1/4" length of leftover 4-wire cable and separate it for its full length between the blue and violet wires. Discard the green and blue 2-wire cable.

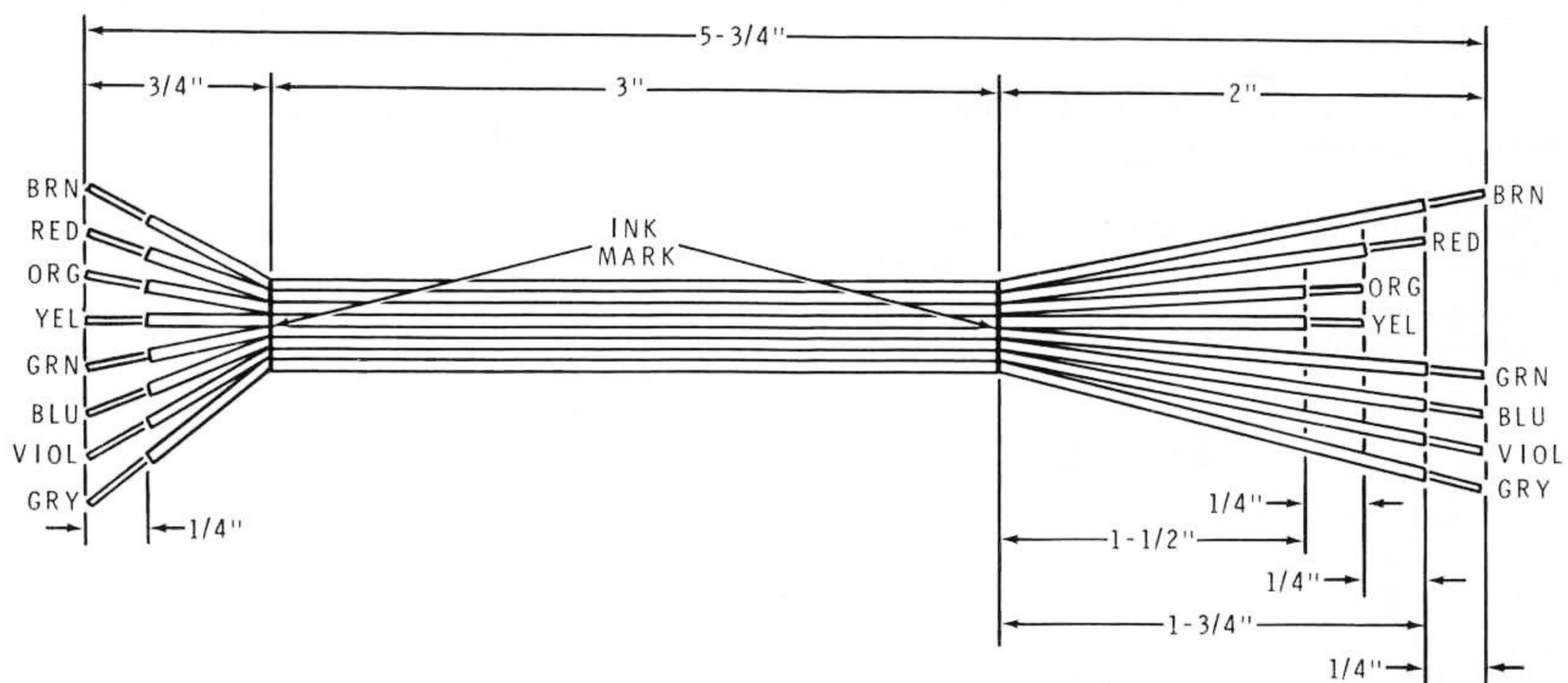

Detail 2-7C

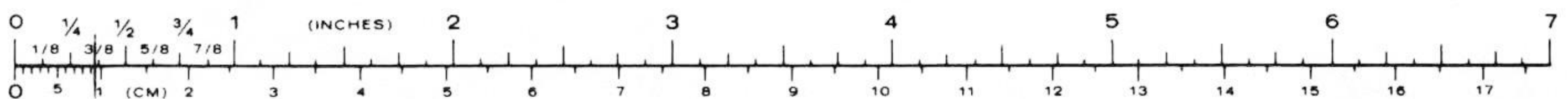

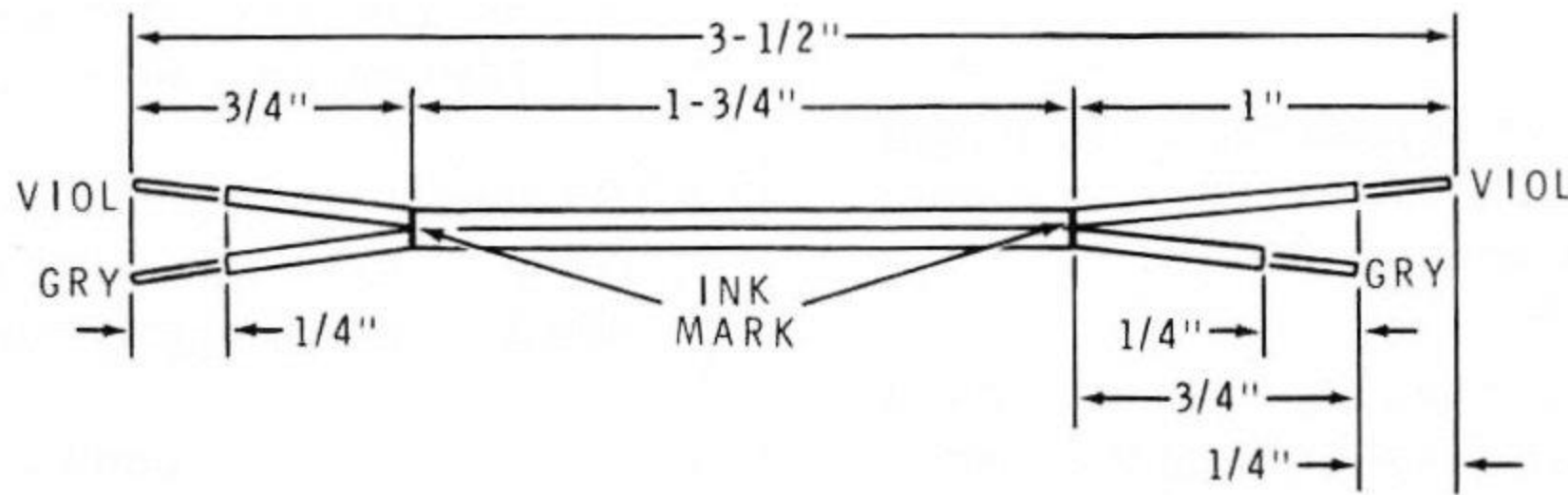

Detail 2-7D

- ( ) Refer to Detail 2-7D and prepare a 3-1/2" long 2-wire cable from the violet and gray wires.
- ( ) Solder the wires at the even end of this 2-wire cable into holes Y (gray) and N (violet) of the display circuit board.
- ( ) Clip off any excess wire lengths of the cable wire ends that extend from the printed side of the display circuit board.

Refer to Pictorial 2-8 (Illustration Booklet, Page 4) for the following steps.

- ( ) Refer to the inset drawing on Pictorial 2-8 and make a fold (90 degree bend) in the 4-wire cable 1-1/2" from the indicated edge of the display circuit board. Position the yellow wire

as shown. Also position the other three cables back over the printed side of the circuit board so they are out of the way while you perform the following steps.

Position the display circuit board on the main circuit board and connect the free end of the 4-wire cable to the main circuit board as follows. Insert the cable wires into the circuit board holes from the lettered side and solder them to the foil on the other side. Then cut off any excess lead lengths.

- ( ) Yellow wire into hole H.
- ( ) Orange wire into hole F.
- ( ) Brown wire into hole E.
- ( ) Red wire into hole D.



Refer to Pictorial 2-9 for the following steps.

( ) Position the 8-wire cable with the gray wire coming from hole J in the display circuit board onto the main circuit board. Make a fold in the cable 1-3/4" from the top edge of the display circuit board.

Solder the wires from the free end of this cable to the holes in the main circuit board as follows. Then cut off any excess lead lengths.

( ) Orange wire into hole G.

( ) Brown wire into hole B.

( ) Red wire into hole A.

( ) Yellow wire into hole C.

( ) Blue wire into hole L.

( ) Green wire into hole M.

( ) Gray wire into hole J.

( ) Violet wire into hole K.

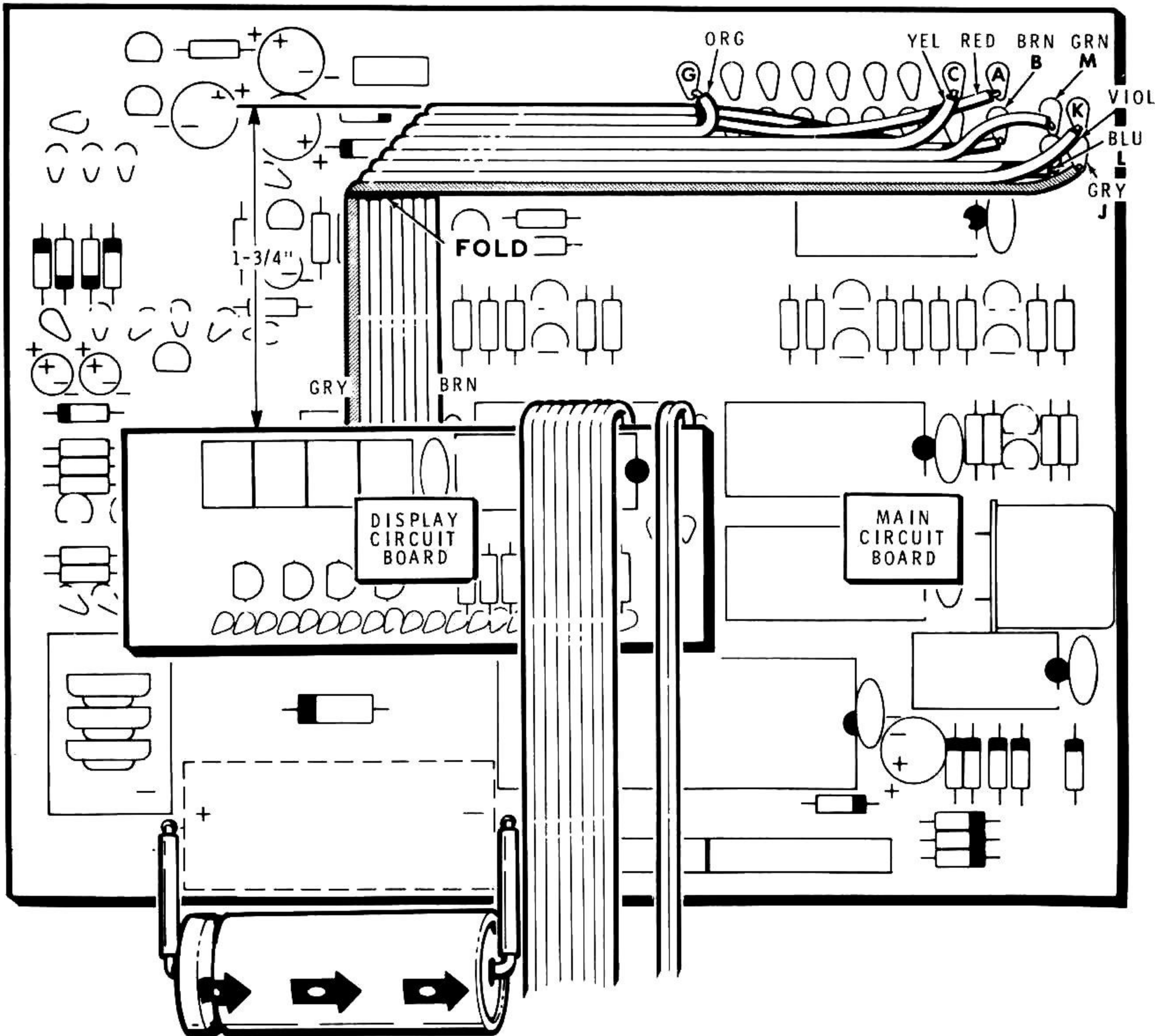

PICTORIAL 2-9

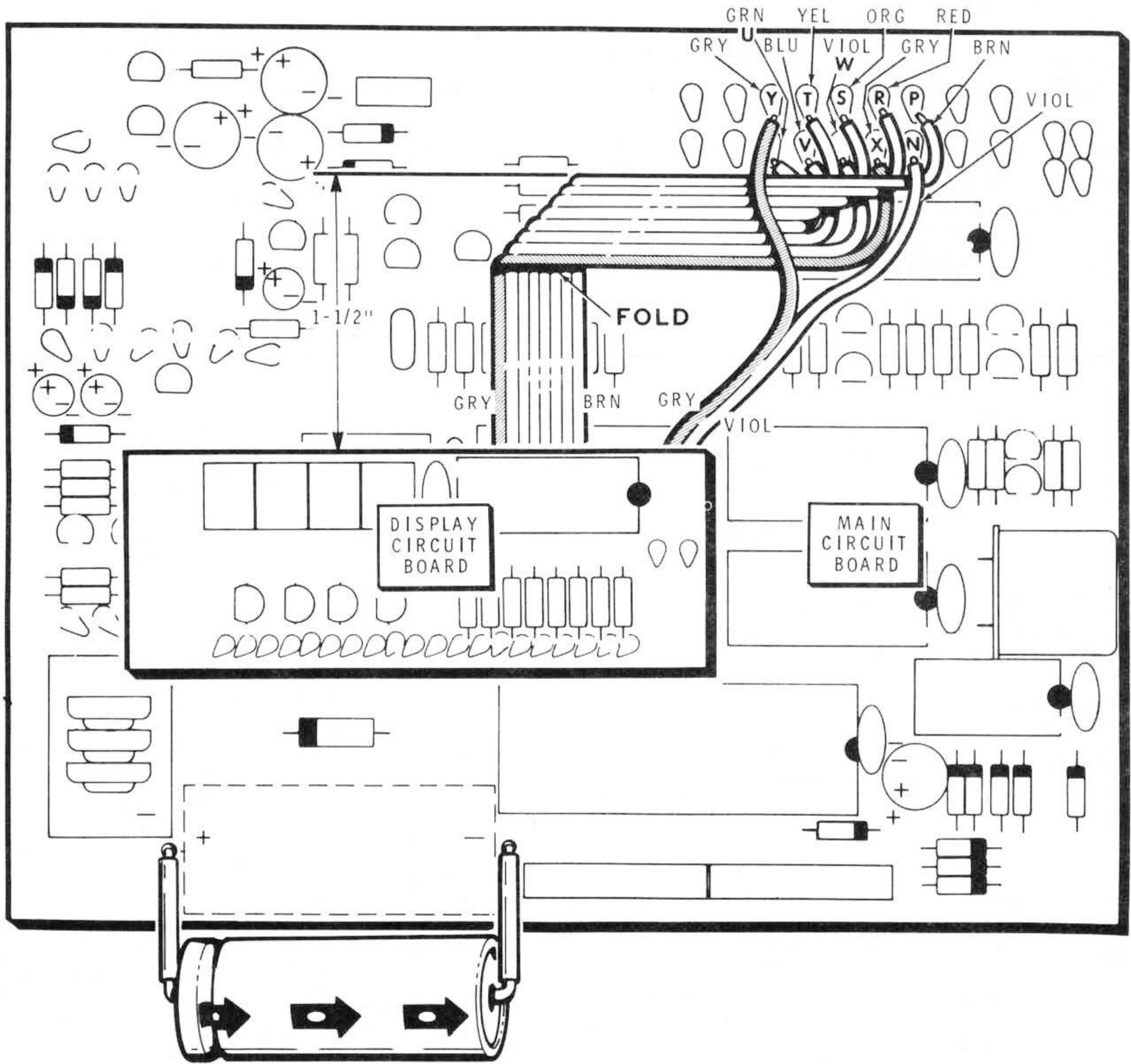

PICTORIAL 2-10

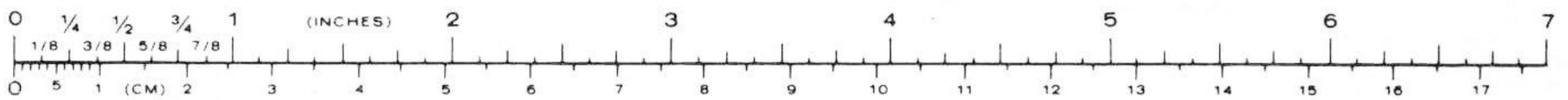

Refer to Pictorial 2-10 for the following steps.

- ( ) Position the remaining 8-wire cable coming from the display circuit board onto the main circuit board. Make a fold in the cable 1-1/2" from the top edge of the display circuit board.

Solder the wires from the free end of this cable into the holes in the main circuit board as follows. Then cut off any excess lead lengths.

- ( ) Green wire into hole U.
- ( ) Blue wire into hole V.
- ( ) Yellow wire into hole T.
- ( ) Violet wire into hole W.
- ( ) Orange wire into hole S.
- ( ) Gray wire into hole X.
- ( ) Red wire into hole R.
- ( ) Brown wire into hole P.

Solder the free end of the 2-wire cable coming from the display circuit board into the holes in the main circuit board as follows:

- ( ) Gray wire into hole Y.
- ( ) Violet wire into hole N.

Refer to Pictorial 2-11 (Illustration Booklet, Page 4) for the following steps.

- ( ) Position the display circuit board on the main circuit board as shown in position #1.
- ( ) Cut a 16" length of 8-wire cable. Then refer to Detail 2-11A (Illustration Booklet, Page 5) and prepare the ends of the cable as shown.

- ( ) Position this cable along the indicated edge of the main circuit board so the cable end with the most even ends is toward the left and the brown wire is closest to the circuit board.
- ( ) Near the left end of the cable, fold the 4-wire part of the cable consisting of the brown, red, orange, and yellow wires as shown.

Solder the wires at the left end of this cable to the main circuit board as follows. Then cut off any excess lead lengths.

- ( ) Yellow wire into hole DD.
- ( ) Orange wire into hole CC.
- ( ) Brown wire into hole LL.
- ( ) Red wire into hole EE.
- ( ) Violet wire into hole AA.
- ( ) Blue wire into hole BB.
- ( ) Green wire into hole GG.
- ( ) Gray wire into hole FF.

- ( ) Reposition the display circuit board so it is toward the rear edge of the main circuit board (position #2).

- ( ) Cut a 14" length of 8-wire cable. Separate the wires for their full length between the orange and yellow wires, and between the green and blue wires. Use the 2-wire (green and yellow) cable in the next step and save the brown, red, and orange 3-wire cable, and the gray, violet, and blue 3-wire cable for use later.

- ( ) Refer to Detail 2-11B and prepare the ends of the 14" green and yellow 2-wire cable as shown.

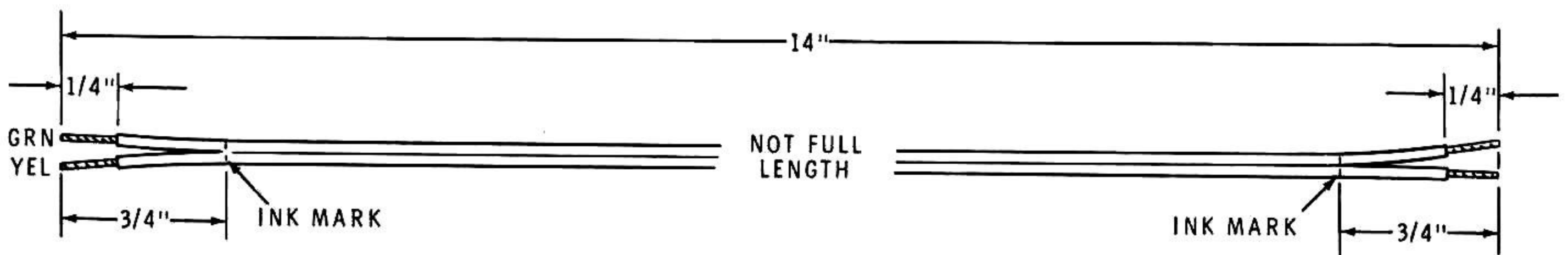

**Detail 2-11B**

Solder the wires at either end of this cable to the main circuit board as follows:

- Green wire into hole HH.
- Yellow wire into hole JJ.
- Position the free end of the green and yellow 2-wire cable under the brown, orange, and yellow wires (coming from holes LL, CC, and DD on the main circuit board) and toward the right under the cables coming from the display circuit board.
- Refer to the inset drawing on Pictorial 2-11 and install a cable tie around the green and yellow 2-wire cable and around the cable coming from holes J, K, L, and M on the main circuit board. Pass the pointed end up through the cable tie end, and pull the cable tie tight and into one of its top slots. Then cut off its excess one notch from the cable tie slot.
- Refer to Detail 2-11C (Illustration Booklet, Page 5) and prepare a 3" length of 3-wire cable from the 3-wire gray, violet, and blue cable you set aside earlier. Save the remaining length of 3-wire cable for use later.
- At the end of the cable with only 1/8" of insulation removed, install a spring connector on each wire following the instructions in Detail 2-11C.
- Align the flat of the spring connectors with the notch side of the 3-pin socket shell and push the connectors into the socket shell until the connectors snap into place. Be sure you position the proper color wire at its correct location.

Solder the wires of this cable assembly into the main circuit board holes as follows:

- Blue wire into hole IN.
- Violet wire into hole COM.
- Gray wire into hole OUT.

### CIRCUIT BOARD CHECKOUT

Carefully inspect the circuit board for the following conditions:

- Unsoldered connections.
- Poor solder connections.
- Solder bridges between foil patterns.
- Protruding leads which could touch together.
- Transistors for the proper type and installation.
- Electrolytic capacitors for the correct position of the positive (+) or negative (-) leads.
- Diodes for the proper type and correct position of the banded end.

NOTE: The integrated circuits will be installed later during "Initial Tests."





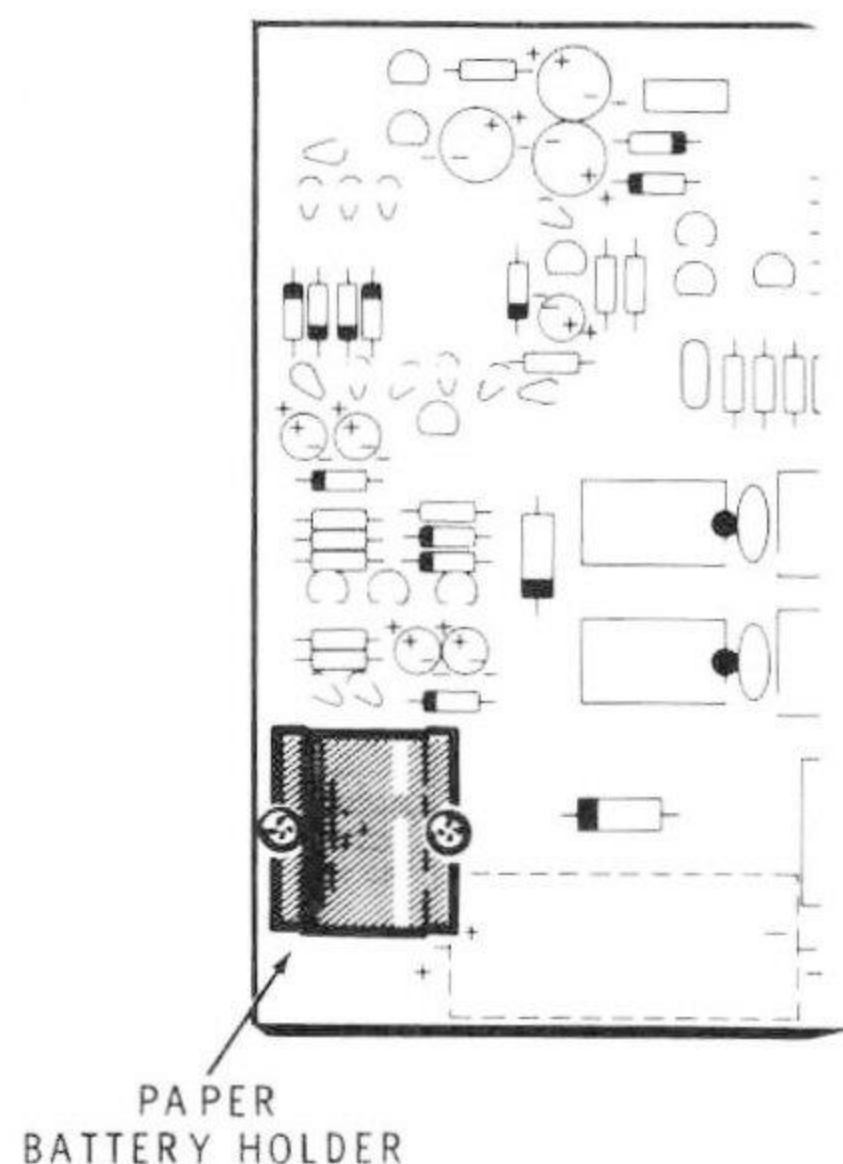

PICTORIAL 2-12

## ASSEMBLY CONTINUED

Refer to Pictorial 2-12 for the following steps.

- ( ) Refer to Detail 2-12A and cut the battery holder from the insulator paper. DO NOT remove the protective backing from the insulator paper.
- ( ) Refer again to Detail 2-12A and mount the prepared battery holder to the main circuit board with a 4-40 × 1/4" screw, a #4 lockwasher, and a 4-40 nut at the circuit board hole nearest the "B2" lettering. Do not overtighten the hardware.
- ( ) B1, B2, B3: Install the three 1.5-volt batteries (#418-37) between the battery contacts. Be sure the small side of each battery is positioned as shown on the circuit board.
- ( ) Wrap the battery holder around the batteries and secure the other side of the holder with a 4-40 × 1/4" screw, a #4 lockwasher, and a 4-40 nut. Do not overtighten the hardware.

Set the circuit board assembly and the bag of integrated circuits aside temporarily. Proceed to "Chassis."

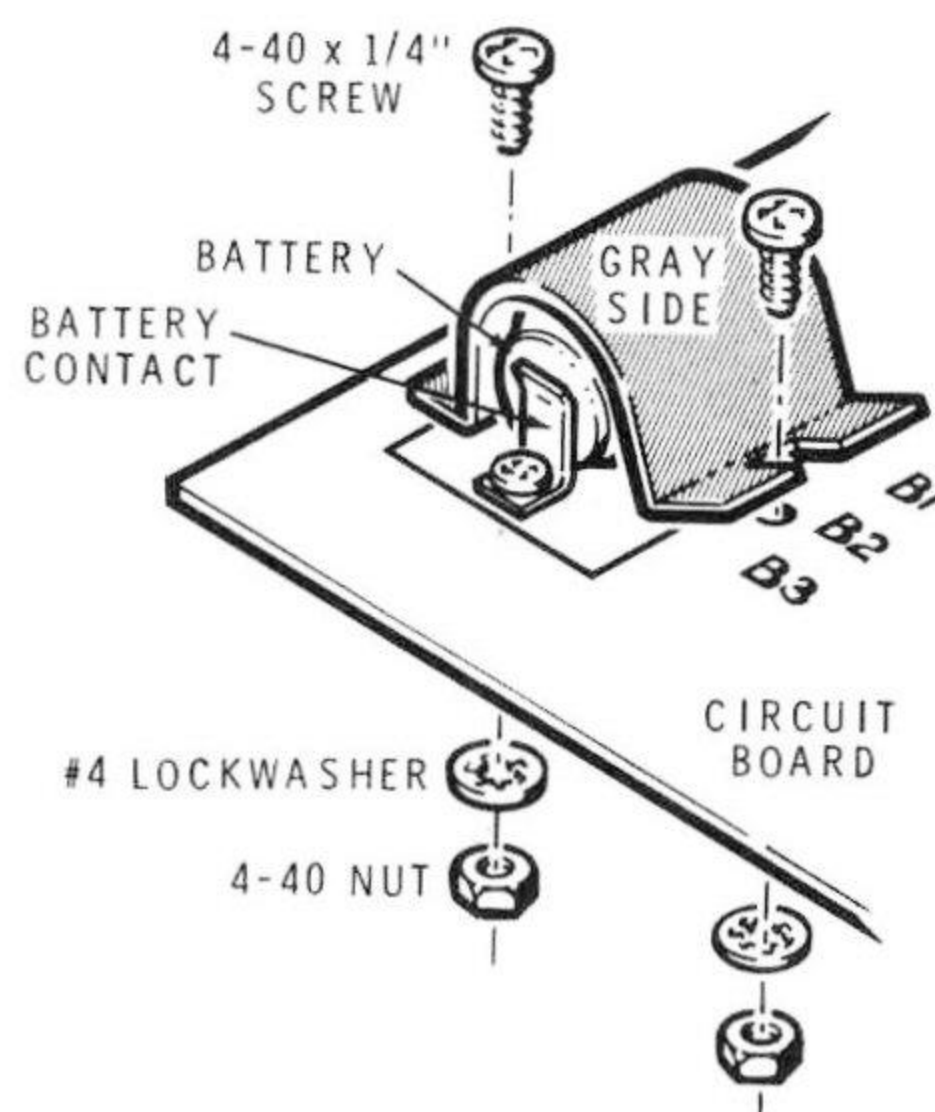
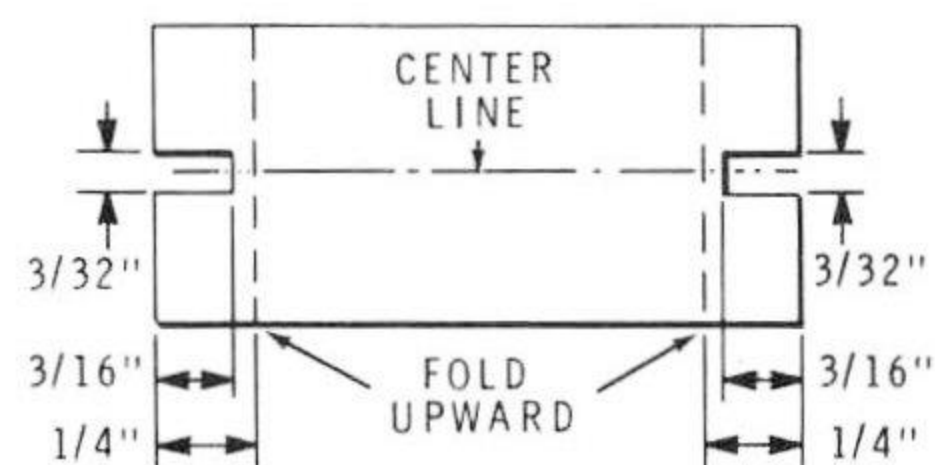
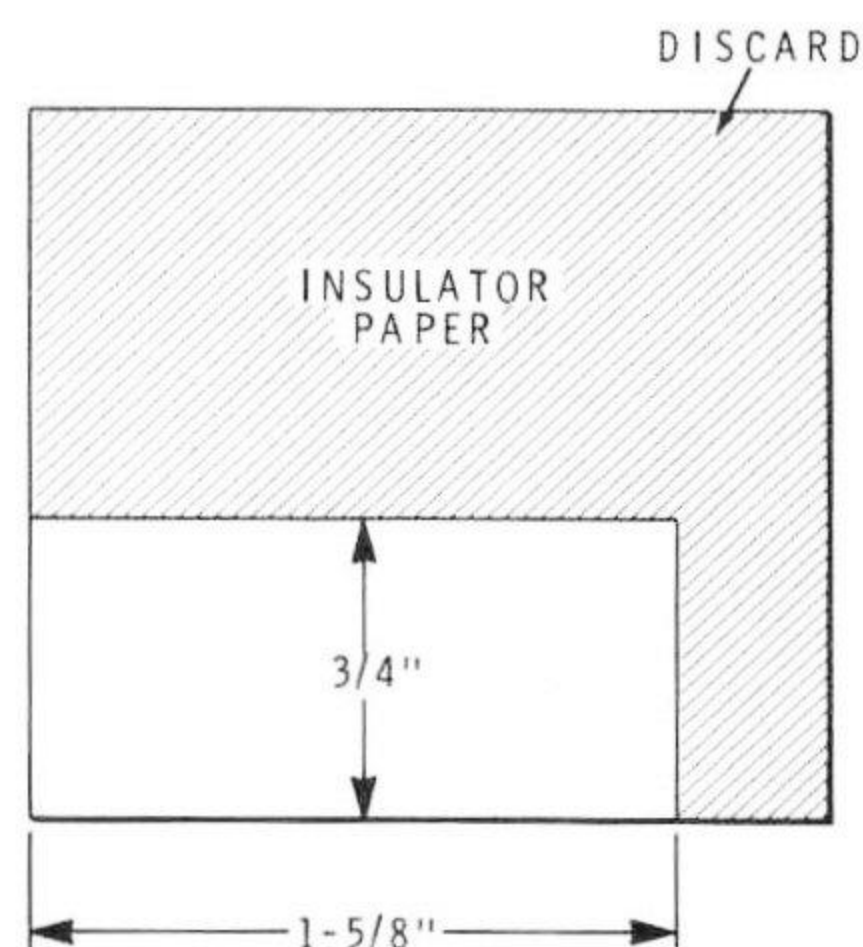

Detail 2-12A



# CHASSIS

## PARTS LIST

Unpack the remainder of the kit. Then check each part against the following list. The key numbers correspond to the numbers on the "Chassis Parts Pictorial" (Illustration Booklet, Pages 6 and 7). Return any part that is packed in an individual envelope, with the part number on it, back into its envelope until that part is called for in a step. Do not throw away any packing material until you account for all the parts.

To order a replacement part, always include the PART NUMBER. Use the Parts Order Form furnished with this kit. If a Parts Order Form is not available, refer to "Replacement Parts" inside the rear cover of this Manual. For prices, refer to the separate "Heath Parts Price List."

KEY No.	HEATH Part No.	QTY.	DESCRIPTION	CIRCUIT Comp. No.
---------	----------------	------	-------------	-------------------

### ELECTRONIC COMPONENTS

A1	6-101-12	1	100 $\Omega$ , 1/4-watt, 5% (brn-blk-brn) resistor	R102
A2	10-237	1	200 $\Omega$ control	R101
A3	21-140	5	.001 $\mu$ F ceramic capacitor	C101, C102, C103, C104, C105
A4	60-72	1	Slide switch (momentary)	S101
A5	60-607	1	Rocker switch	S102
A6	64-911	1	Keyboard assembly	
A7	401-163	1	Speaker	SP101
A8	442-54	1	7805 integrated circuit	U101

KEY No.	HEATH Part No.	QTY.	DESCRIPTION	CIRCUIT Comp. No.
---------	----------------	------	-------------	-------------------

### HARDWARE

Hardware packets are marked to show the size of the hardware they contain (HDW #4, or, HDW #2 & #6, etc.). You may have to open more than one packet — in this pack — to locate all the hardware of any one (#6, for example) size.

#### #4 Hardware

B1	250-1411	5	4-40 $\times$ 1/4" screw
B2	250-1412	2	4-40 $\times$ 3/8" screw
B3	250-1319	2	4-40 $\times$ 5/8" screw
B4	252-2	5	4-40 nut
B5	254-9	5	#4 lockwasher

KEY No.	HEATH Part No.	QTY.	DESCRIPTION	CIRCUIT Comp. No.
---------	----------------	------	-------------	-------------------

**#6 Hardware**

C1	250-1280	11	6-32 × 3/8" screw	
C2	250-1305	4	#6 × 5/8" self-tapping screw	
C3	250-1331	2	6-32 × 5/8" screw	
C4	252-3	7	6-32 nut	
C5	253-60	4	#6 flat washer	
C6	254-1	7	#6 lockwasher	
C7	259-6	1	#6 solder lug	

**Other Hardware**

D1	252-7	2	Control nut	
D2	253-10	2	Control flat washer	
D3	253-15	1	Fiber flat washer	
D4	253-16	1	Fiber shoulder washer	
D5	254-4	2	Control lockwasher	
D6	255-13	2	1/4" long spacer	
D7	255-77	2	7/16" long spacer	
D8	266-929	4	Plastic insert	

**CONNECTORS – SOCKETS – PLUGS**

E1	432-72	2	Male terminal pin	
E2	432-73	4	Female terminal pin	
E3	432-196	2	2-pin plug shell	
E4	432-866	20	Spring connector (includes 2 extra)	

KEY No.	HEATH Part No.	QTY.	DESCRIPTION	CIRCUIT Comp. No.
---------	----------------	------	-------------	-------------------

**Connectors – Sockets – Plugs (Cont'd.)**

E5	432-907	1	2-pin socket shell	
E6	432-958	2	10-pin socket shell	
E7	434-42	2	Phono socket	J101, J102
E8	436-19	1	Phone jack	J103
E9	438-4	1	Phono plug	
E10	438-55	1	Polarizing pin	

**SHEET METAL PARTS**

F1	204-1856	1	Speaker mounting bracket	
F2	204-2578	1	Right keyboard mounting bracket	
F3	204-2579	1	Left keyboard mounting bracket	
F4	204-2659	1	Circuit board mounting bracket	
F5	205-1895-1	1	Chassis	

**MISCELLANEOUS**

G1	74-46	1	Double-stick tape (1/8" × 1-1/2")	
G2	92-783	1	Cabinet	
G3	209-87	1	Speaker grille	
G4	261-28	4	Foot	
G5	352-13	1	Silicone grease	
G6	446-744	1	Window	

## STEP-BY-STEP ASSEMBLY

Refer to Pictorial 3-1 (Illustration Booklet, Page 8) for the following steps.

- ( ) Refer to Detail 3-1A and position the chassis upside down. Carefully peel the backing paper from the four feet and press them into place at their outlines on the chassis.
- ( ) Carefully peel the backing paper from the blue and white label. Then press the label into place on the bottom of the chassis. Do not cover any of the printing on the chassis. Be sure to refer to the numbers on the label in any communications you have with the Heath Company about your kit.

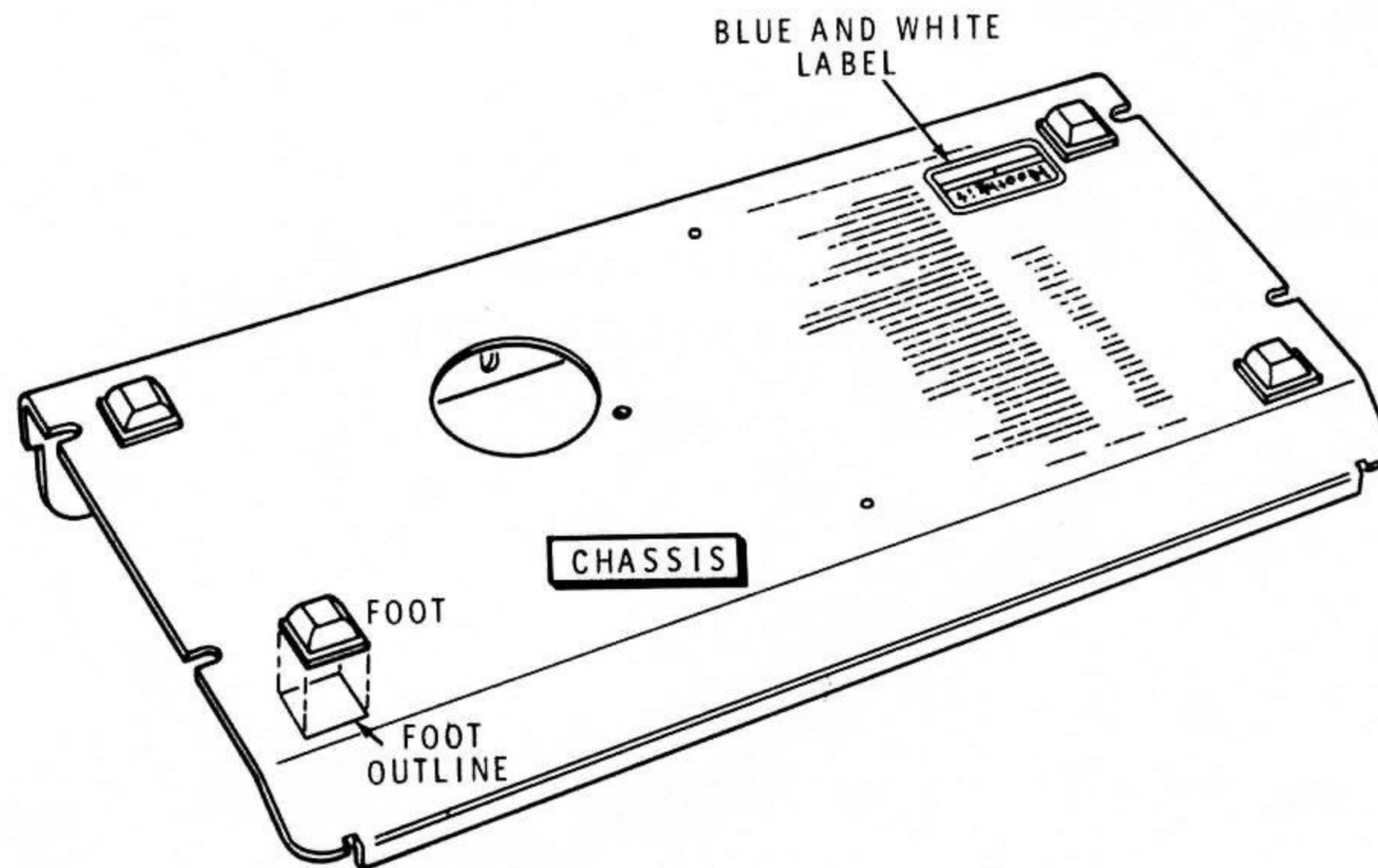

**Detail 3-1A**

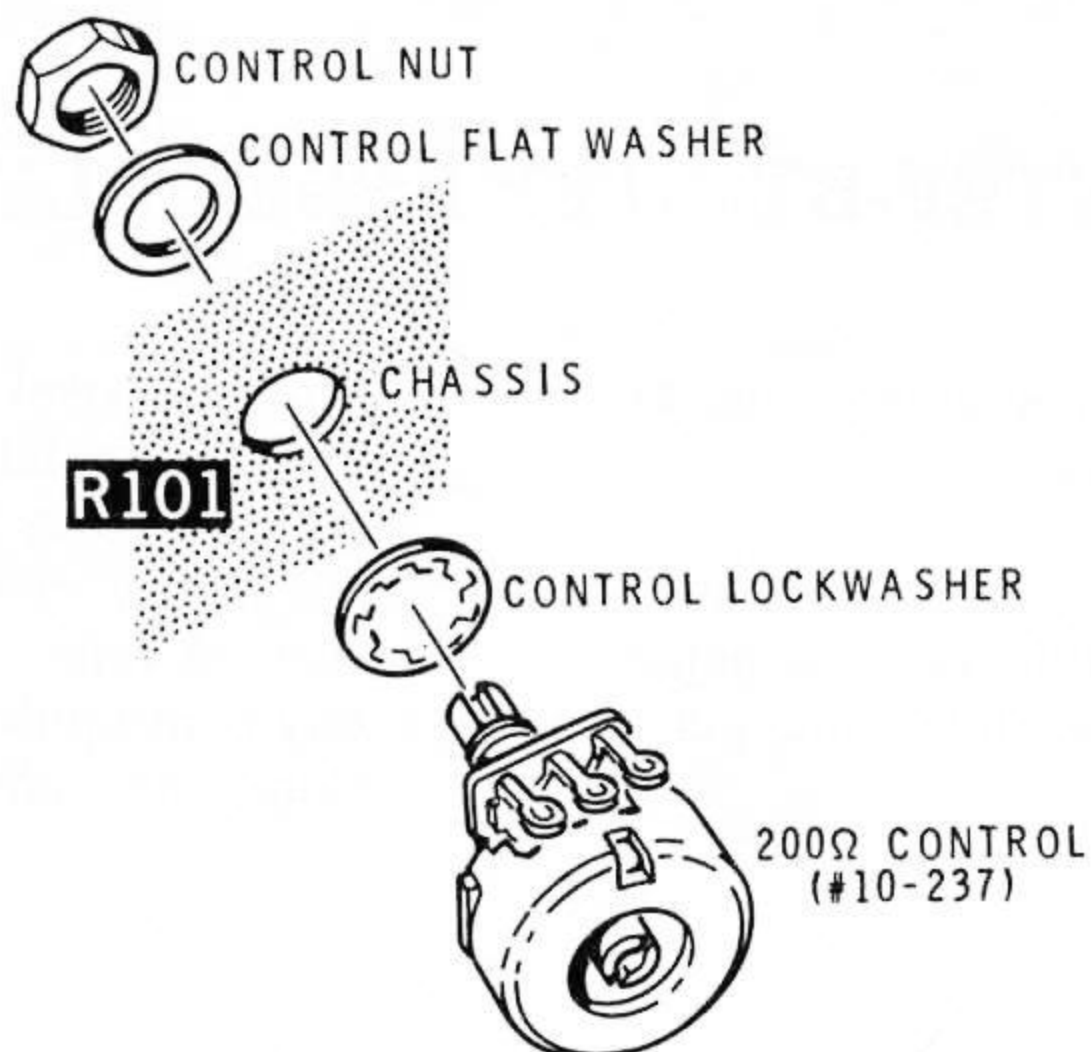

**Detail 3-1B**

- ( ) Reposition the chassis right-side-up as shown in Pictorial 3-1.
- ( ) R101: Refer to Detail 3-1B and mount the 200 Ω control (#10-237) to the chassis at R101. Use a control lockwasher, a control flat washer, and a control nut. Be sure to position the control as shown in the Pictorial.

- ( ) J103: Refer to Detail 3-1C and mount the phone jack to the chassis at J103. Use a control lockwasher, a fiber flat washer, a fiber shoulder washer, a control flat washer, and a control nut. Be sure to position the phone jack as shown in the Pictorial. Also be sure the shoulder on the fiber shoulder washer is in the chassis hole.

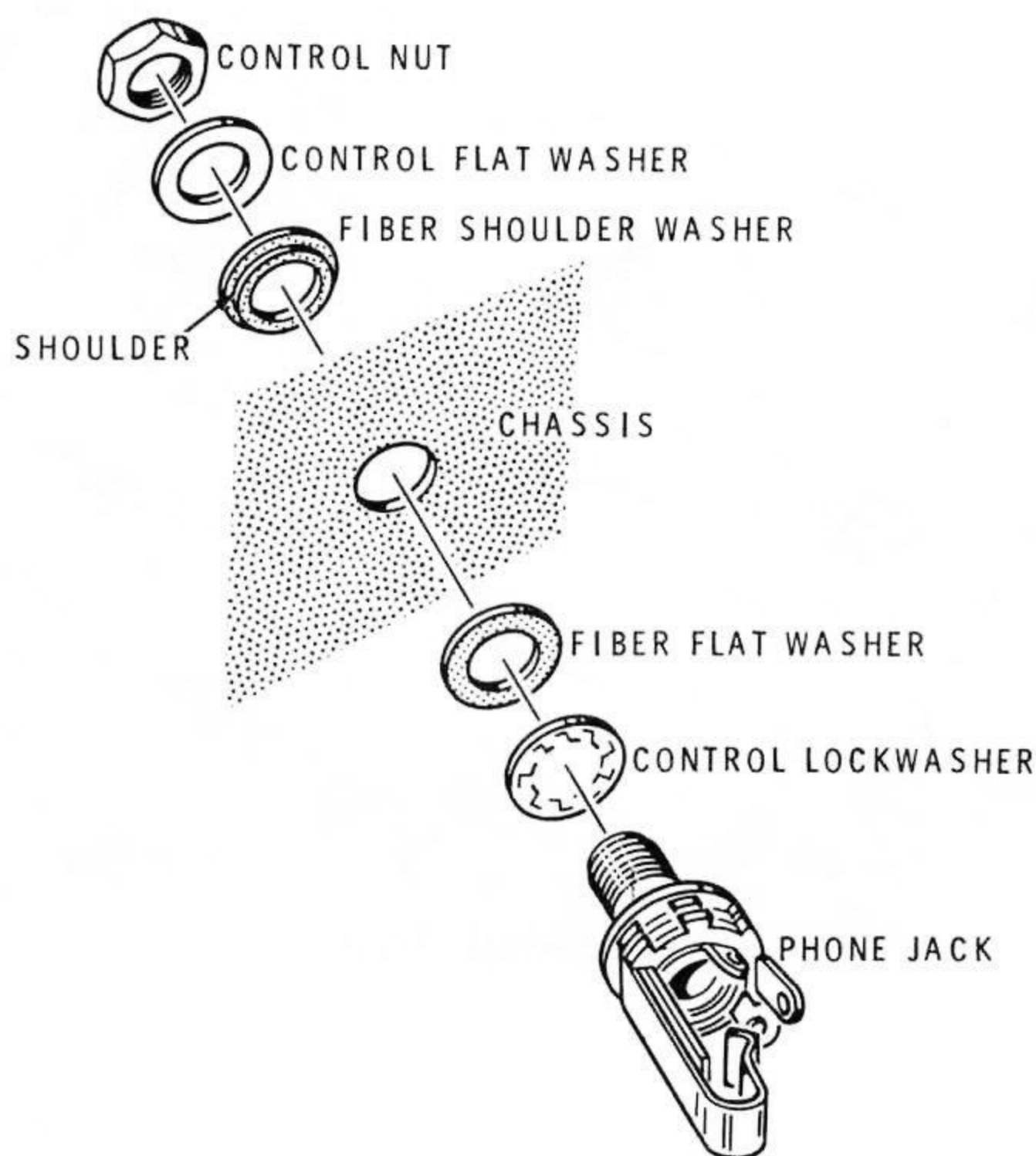

**Detail 3-1C**

( ) J101: Refer to Detail 3-1D and mount a phono socket to the chassis at J101. Use two 6-32 × 3/8" screws, two #6 lockwashers, and two 6-32 nuts. Be sure to position the socket as shown in the Pictorial. Also be sure to center the socket in its opening before you tighten the hardware.

( ) J102: Similarly, mount a phono socket to the chassis at J102. Use two 6-32 × 3/8" screws, two #6 lockwashers, and two 6-32 nuts. Be sure to position the socket as shown in the Pictorial.

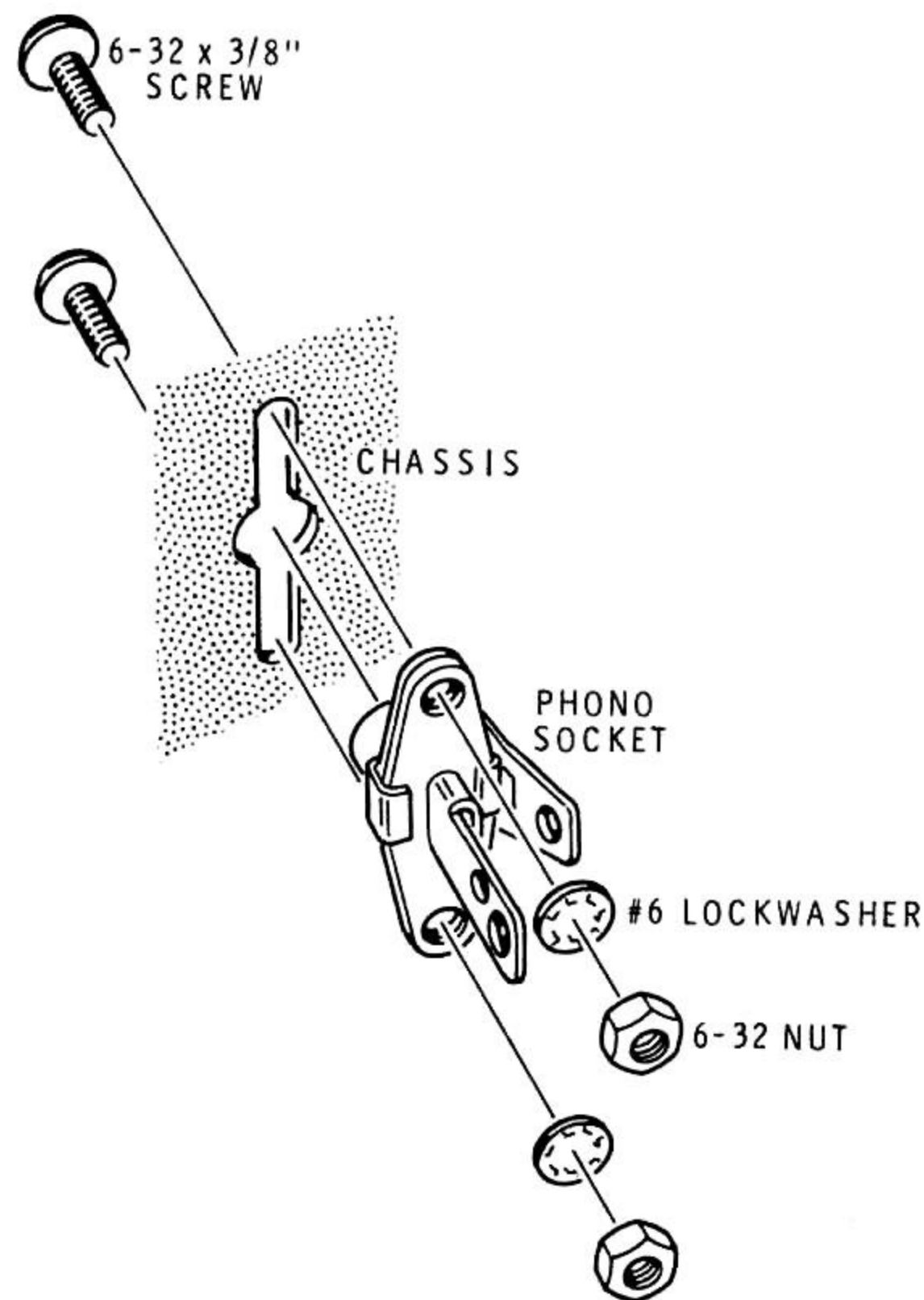

**Detail 3-1D**

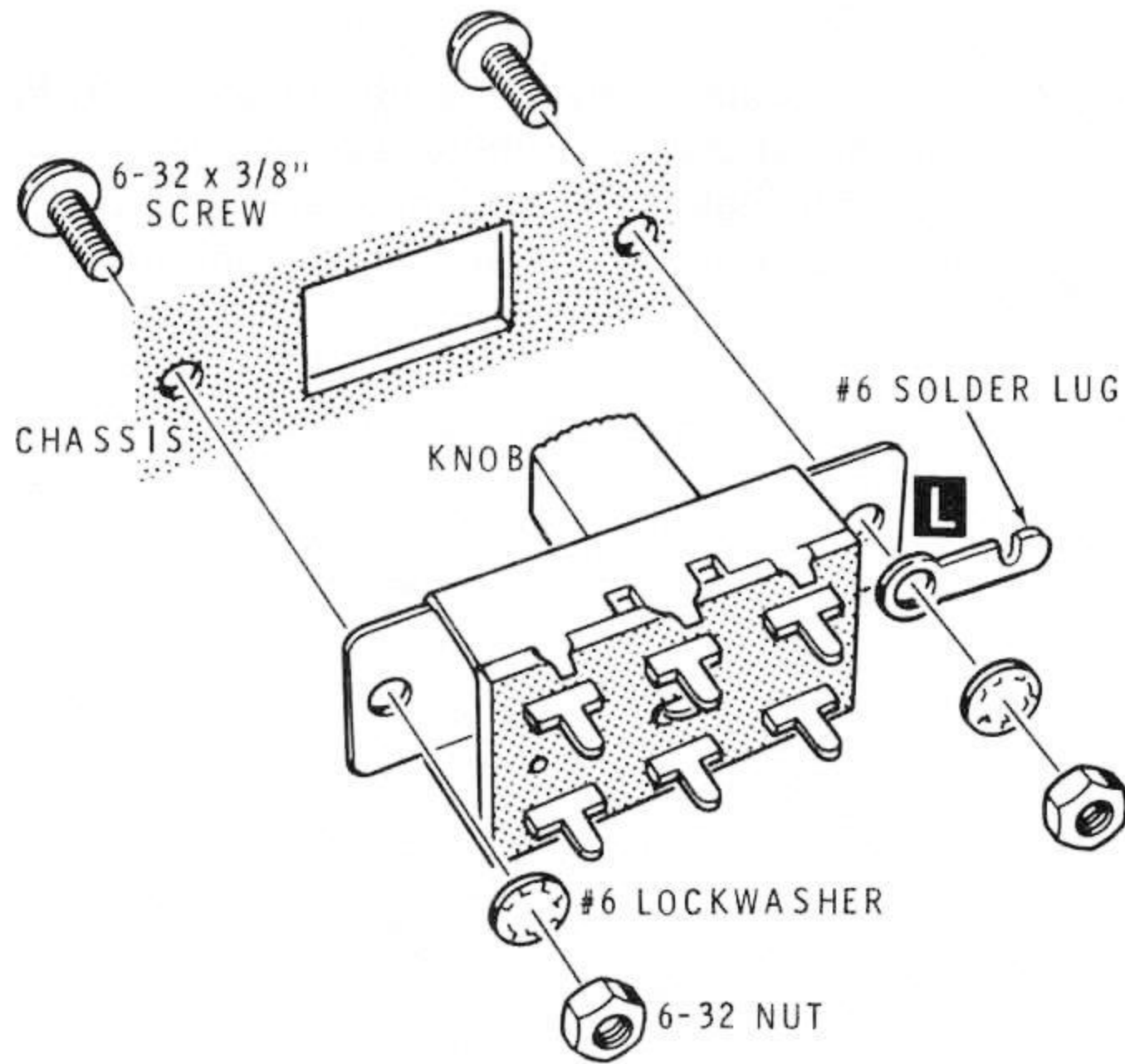

Detail 3-1E

- ( ) S102: Refer to Detail 3-1E and mount the slide switch to the chassis at S102. Use two 6-32  $\times$  3/8" screws, two #6 lockwashers, a #6 solder lug, and two 6-32 nuts. Be sure to mount the #6 solder lug at L. Also be sure to position the switch so its knob is toward the right and the solder lug is toward the right as shown in the Pictorial.
- ( ) Bend solder lug L away from the chassis so it is perpendicular to the rear of the chassis.

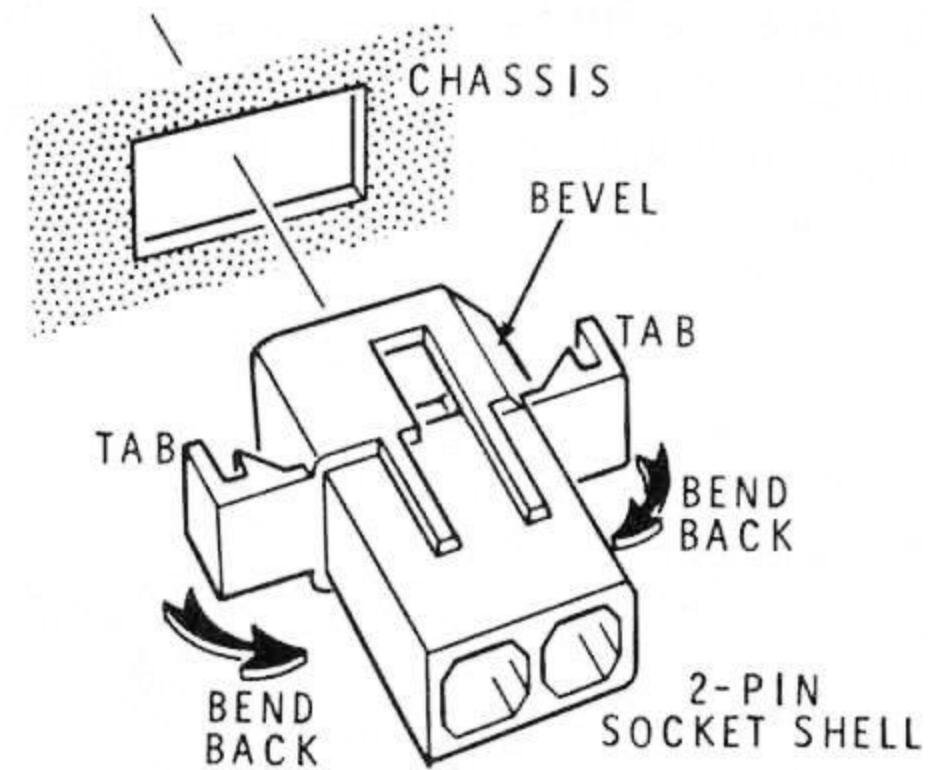

Detail 3-1F

- ( ) J104: Refer to Detail 3-1F and install the 2-pin socket shell in the chassis at J104. Bend its tabs back and insert the socket shell into the chassis slot. Release the tabs to lock the socket shell into place. Be sure to position the beveled side as shown.
- ( ) S101: Refer to Detail 3-1G and mount the rocker switch to the chassis at S101. Use two 6-32  $\times$  5/8" screws and two 7/16" long spacers. Be sure to mount the switch so its lugs are positioned as shown in the Pictorial.

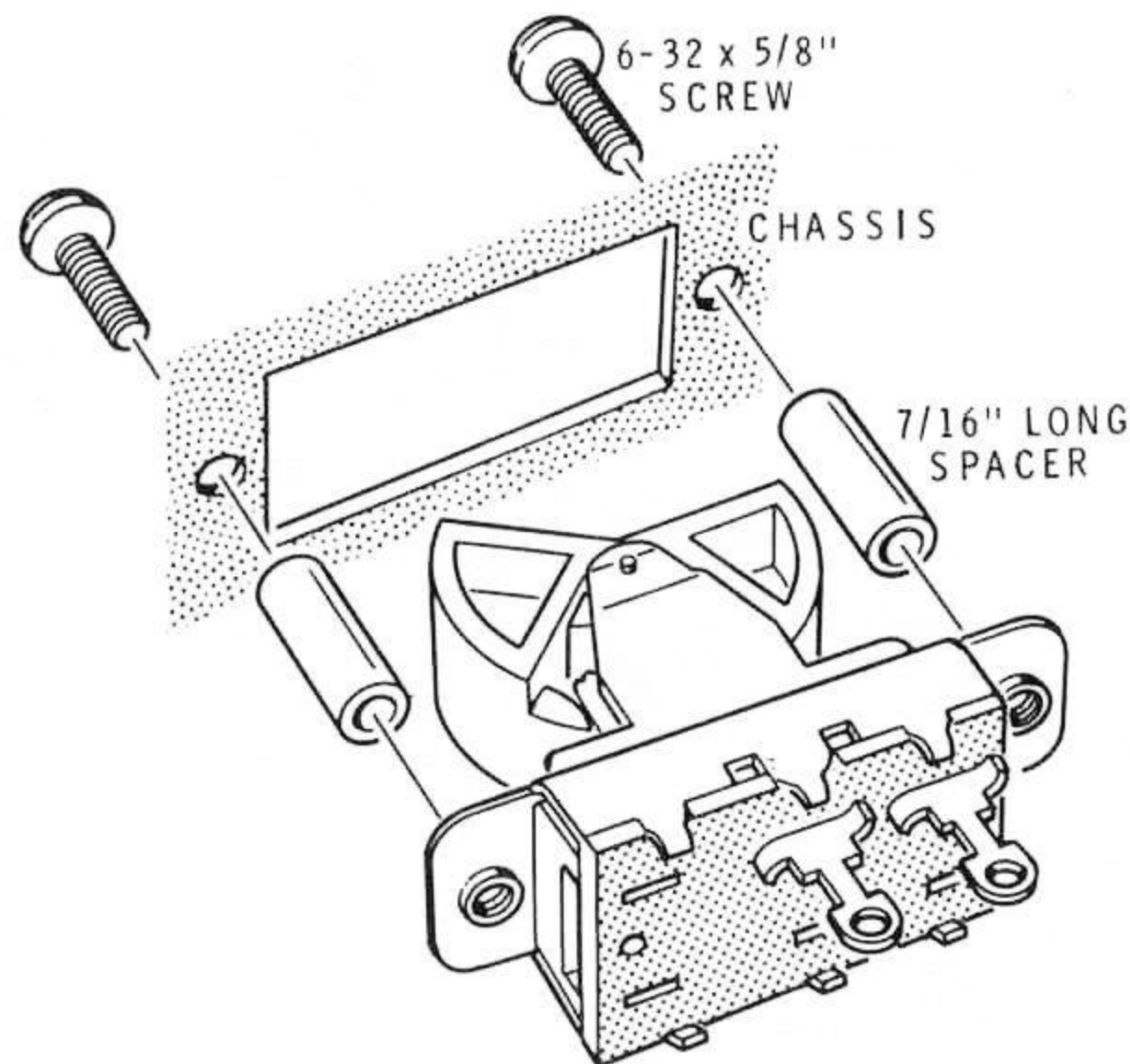

Detail 3-1G



**CAUTION:** When you install the speaker in the next step, handle it carefully so you do not puncture its paper cone. This would damage the speaker.

6-32 × 3/8" screw, a #6 lockwasher, and a 6-32 nut. Be sure to position the speaker as shown in the Pictorial.

( ) SP101: Refer to Detail 3-1H and mount the speaker and speaker grille to the chassis at SP101. Use the speaker mounting bracket, a

( ) Set the chassis aside temporarily.

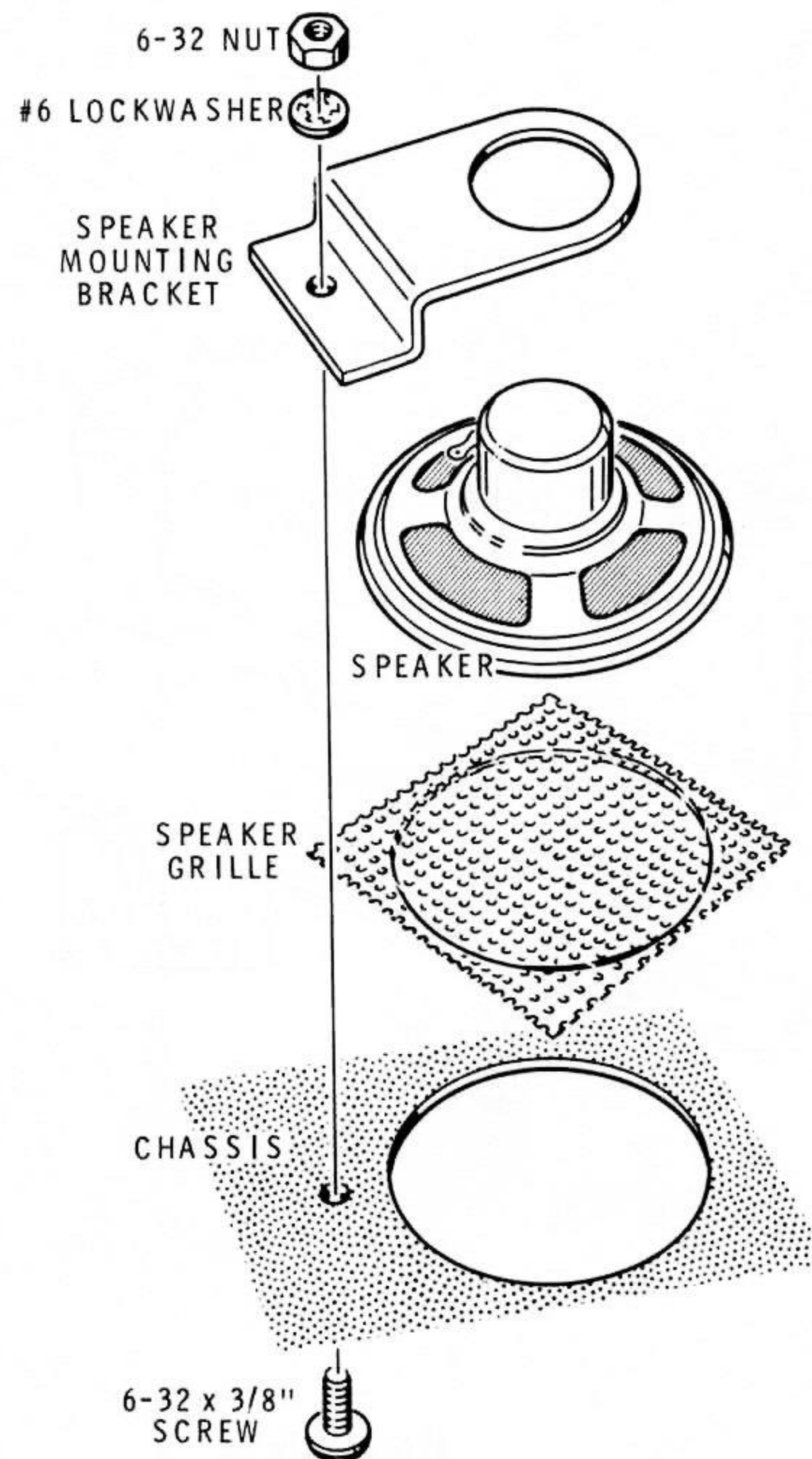

**Detail 3-1H**

**WARNING:** The silicone grease that you will use in the following step helps transfer heat from the IC to the circuit board mounting bracket. The grease is not caustic, but make sure you do not get it into your eyes, ears, nose, mouth, or clothing. Always wash your hands after you use the grease. Keep this and all chemicals out of the reach of children.

- ( ) Refer to the inset drawing on Detail 3-1J and open the packet of silicone grease.

- ( ) U101: Refer to Detail 3-1J and apply a thin layer of silicone grease to the indicated side of the 7805 IC (#442-54). Then mount the IC onto the circuit board mounting bracket. Use a 4-40 × 1/4" screw, a #4 lockwasher, and a 4-40 nut. Be sure to position the IC as shown. Discard the leftover silicone grease.

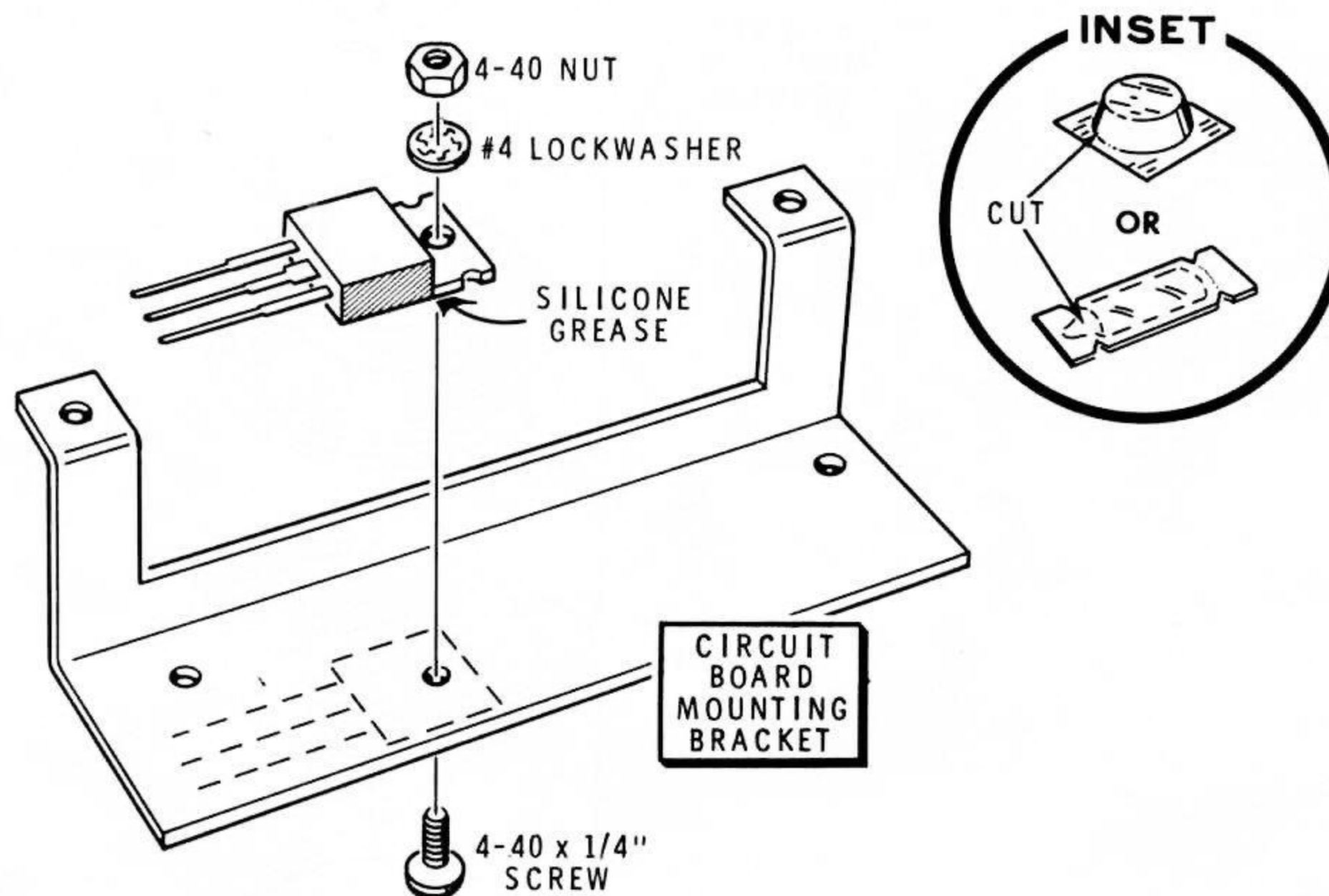

**Detail 3-1J**

# Heathkit®

- ( ) Refer to the inset drawing on Detail 3-1K and position the display circuit board into position above the main circuit board. Then form the cables connected between the two boards as shown and fit the circuit board mounting bracket into place between the two circuit boards.
- ( ) Refer again to Detail 3-1K and secure the display circuit board to the circuit board mounting bracket. Use two 4-40 × 5/8" screws, two 1/4" long spacers, two #4 lockwashers, and two 4-40 nuts.
- ( ) Refer again to Detail 3-1K and secure the display circuit board to the circuit board mounting bracket. Use two 4-40 × 3/8" screws, two #4 lockwashers, and two 4-40 nuts. Be sure you position the cable wires as shown and do not pinch any wires between the bracket and the circuit board.

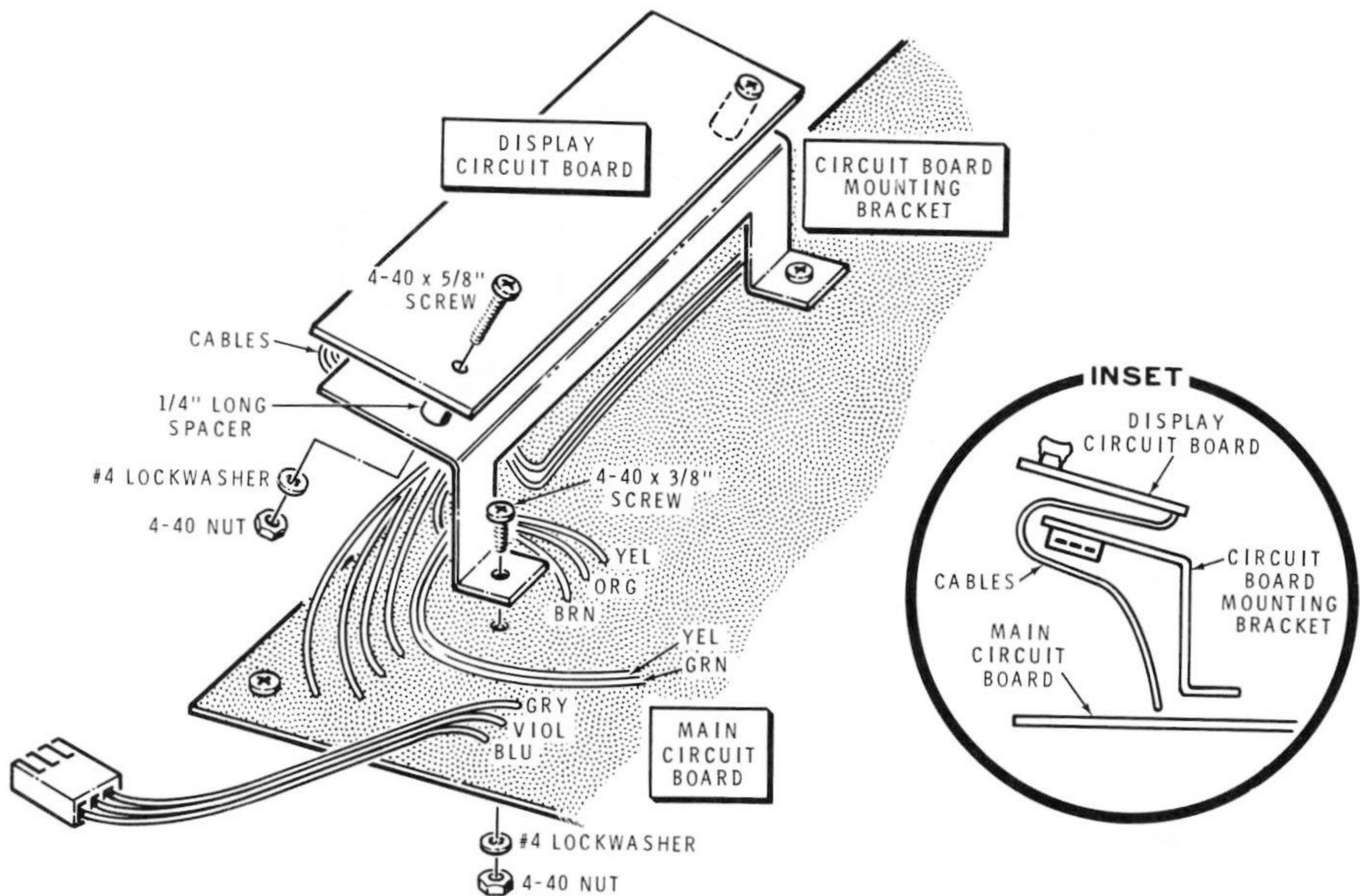

Detail 3-1K

- ( ) Refer to Detail 3-1L and push the 3-pin socket shell coming from the main circuit board onto the pins of U101 (mounted on the circuit board mounting bracket). Be sure the blue wire is positioned as shown (slots in the socket shell away from the bracket).
- ( ) Locate the violet and blue wires near the free end of the 8-wire cable coming from the main circuit board.
- ( ) Cut **one** lead of two .001  $\mu$ F ceramic capacitors to 1/2".

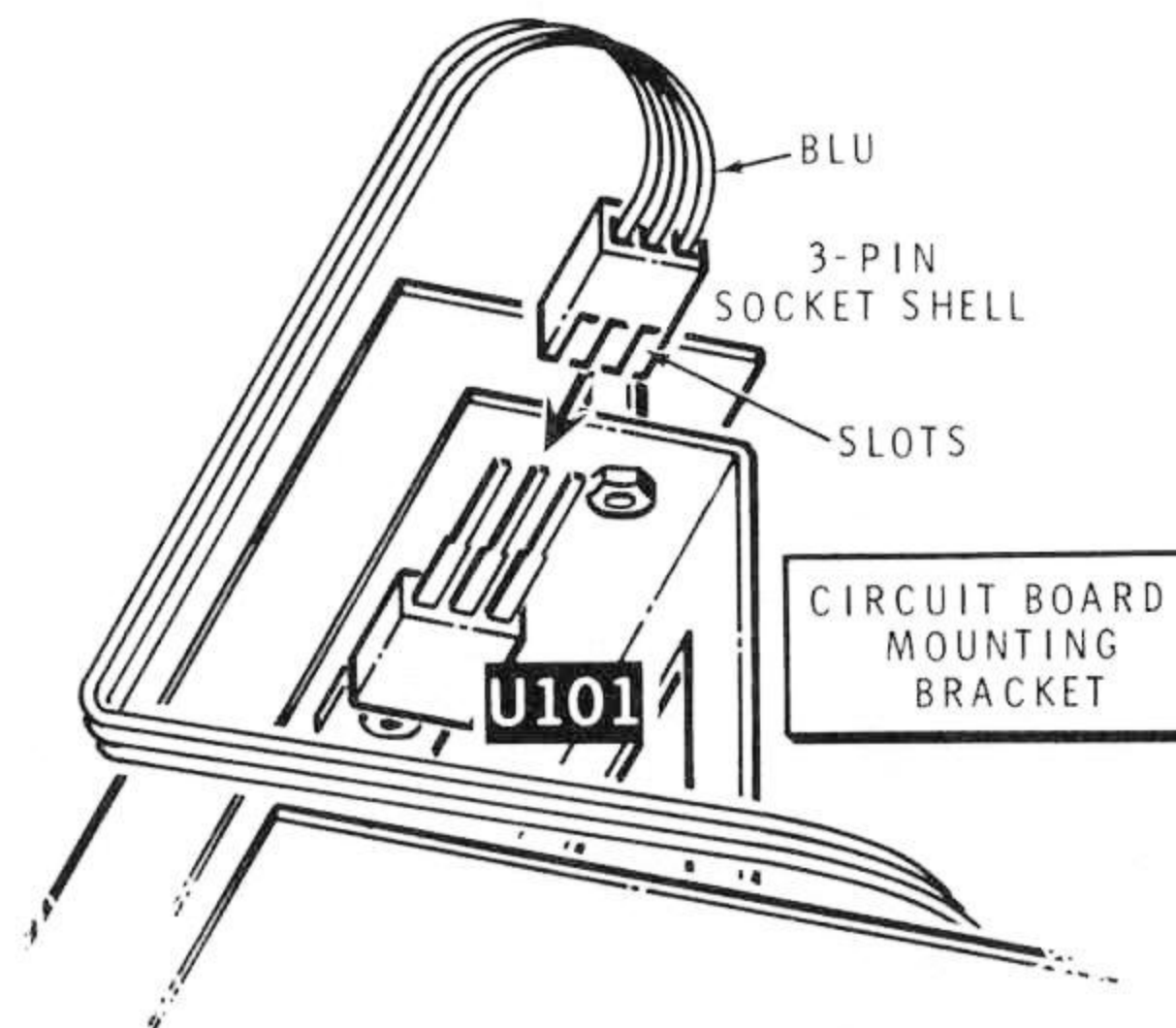

Detail 3-1L



- ( ) C103: Refer to Detail 3-1M and install a male terminal pin on the end of the short lead of a prepared .001  $\mu$ F ceramic capacitor and the violet cable wire.
- ( ) C104: Similarly, install a male terminal pin on the end of the short lead of the remaining prepared .001  $\mu$ F ceramic capacitor and the blue cable wire.
- ( ) Position the main circuit board into position on the chassis. Position the 8-wire cable flat and down against the circuit board and near the rear of the chassis. The cable must not cover the small hole in the rear of the chassis or you will not be able to adjust control R21, which is mounted on the rear of the main circuit board.

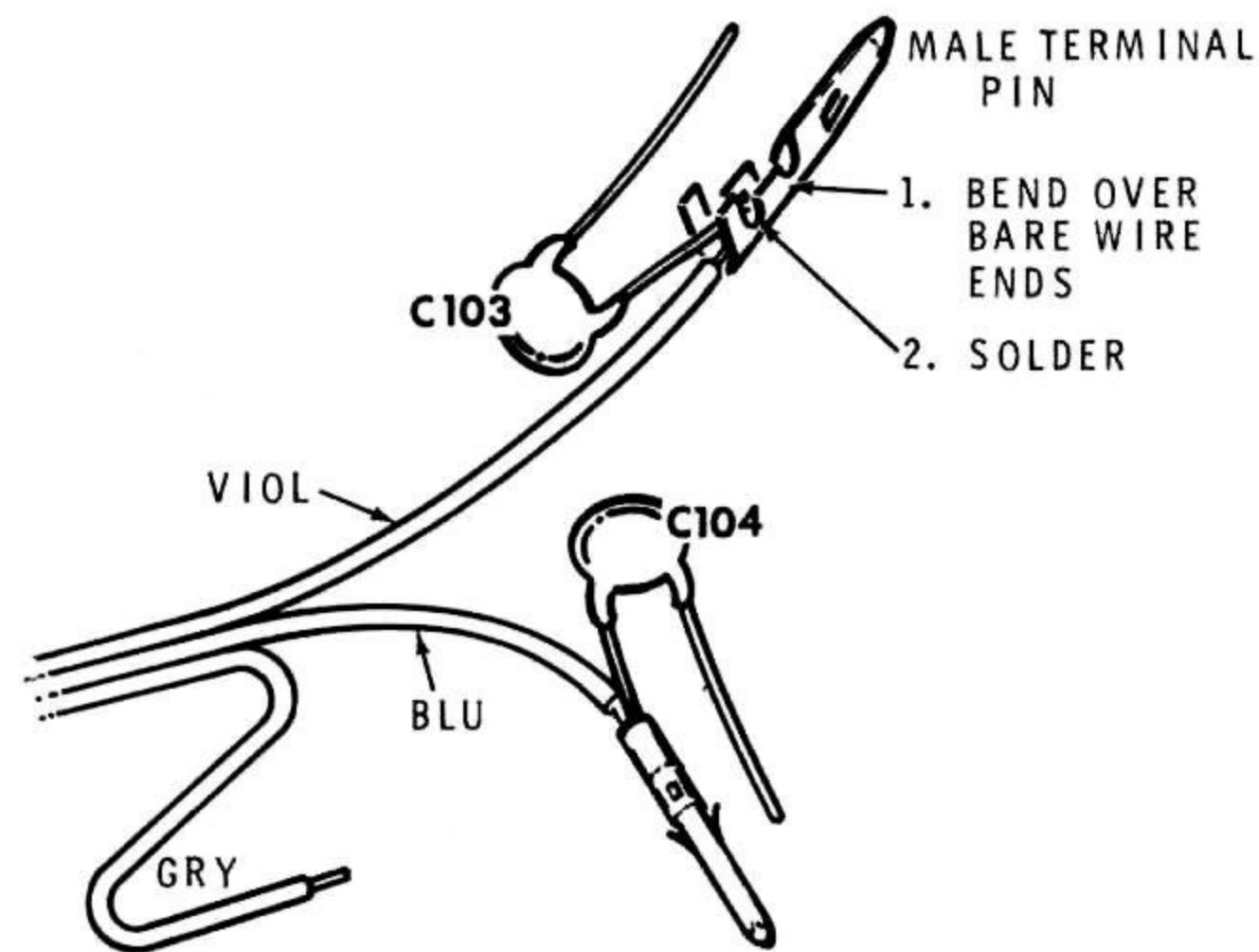

**Detail 3-1M**

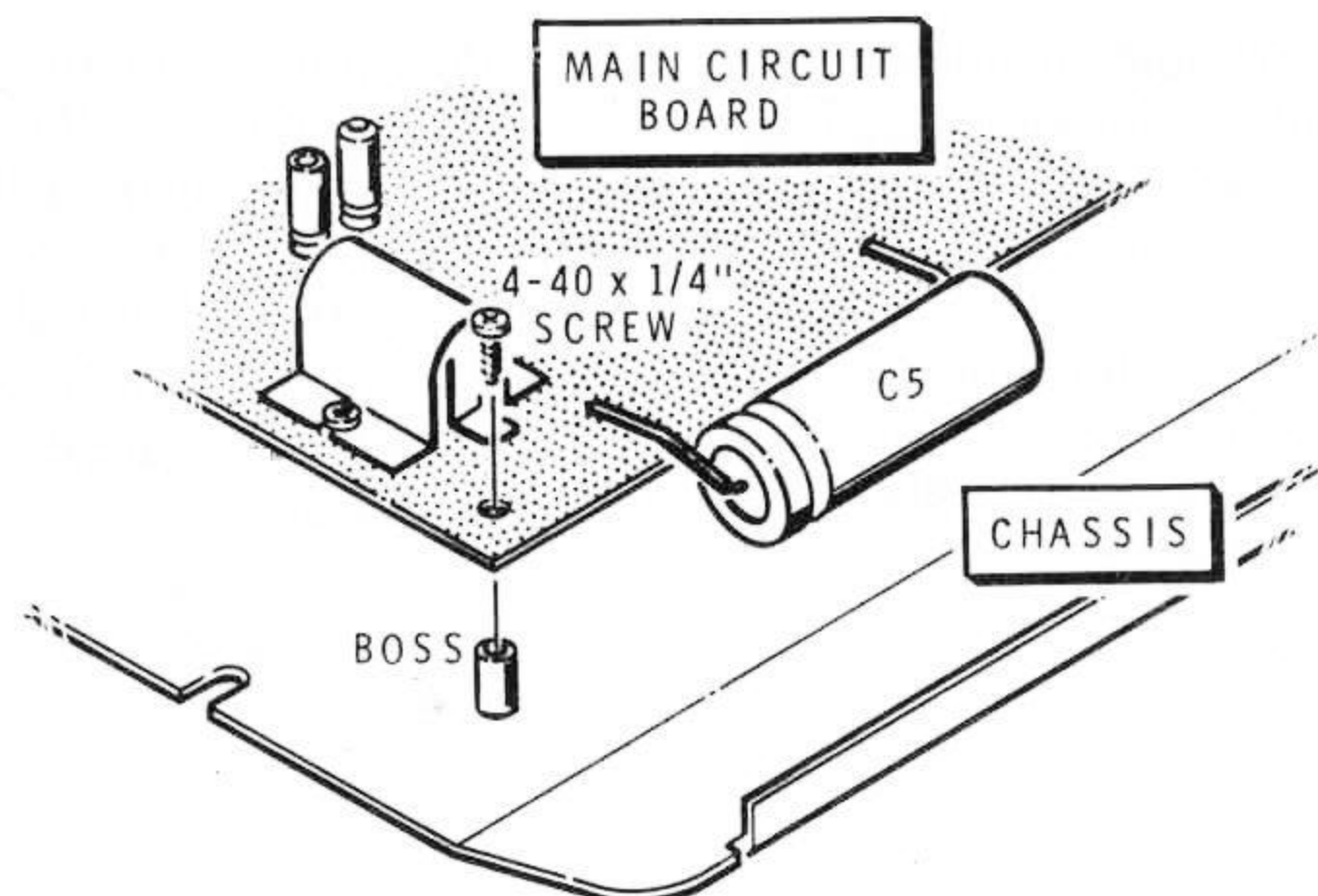

Detail 3-1N

- ( ) Refer to Detail 3-1N and use four 4-40 × 1/4" screws to secure the corners of the main circuit board to the bosses on the chassis.
- ( ) Press capacitor C5 down against the chassis.

NOTE: In the following steps, (NS) means not to solder because you will add other wires later. "S-" with a number, such as (S-3), means to solder the connection. The number following the "S-" tells you how many wires should be at the connection. This helps you check your work for errors as you go.

Connect the free end of the 8-wire cable to the components on the rear of the chassis as follows:

- ( ) Brown wire to control R101 lug 1 (NS).
- ( ) Red wire to control R101 lug 3 (S-1).
- ( ) Orange wire to socket J101 lug 1 (NS).
- ( ) Yellow wire to socket J102 lug 1 (NS).
- ( ) Green wire to switch S102 lug 5 (S-1).
- ( ) Push the male terminal pin on the violet wire into socket J104 hole 1 until it locks into place. The free lead of capacitor C103 will be connected later.

- ( ) Similarly push the male terminal pin on the blue wire into socket J104 hole 2 until it locks into place. The free lead of capacitor C104 will be connected later.

- ( ) Gray wire to switch S101 lug 3 (S-1). NOTE: There is no lug 1 on this switch.

Connect the free ends of the wires of the 2-wire cable coming from the main circuit board as follows:

- ( ) Green wire to switch S102 lug 2 (S-1).
- ( ) Yellow wire to switch S102 lug 3 (S-1).
- ( ) Locate the 11" length of gray, violet, and blue 3-wire cable that you set aside earlier. Then separate the gray and violet wires (as a pair) for their entire length from the blue wire. Cut a 7" length of gray and violet 2-wire cable from these wires and set it aside for use later. Now separate the remaining gray and violet wires and the wires of the 14" brown, red, and orange 3-wire cable (also set aside earlier) into individual wires for use in the following steps. DO NOT cut any wires from the remaining length of 8-wire cable in the following steps. This cable is needed for the keyboard wiring later.

NOTE: When you are directed to prepare a wire, as in the next step, cut the indicated color wire to the specified length and remove 1/4" of insulation from both ends. Then tightly twist the fine wire strands and melt a small amount of solder on the bare wire ends.

- ( ) Prepare the following wires from the separated 8-wire cable wires. The wires are listed in the order in which you will use them.

4" brown	3" red
2-1/2" brown	2-1/2" red
2-1/2" brown	4" gray

- ( ) Bend lug 2 of sockets J101 and J102 as close together as possible.
- ( ) Remove an extra 1/4" of insulation (total 1/2" from one end of the prepared 4" brown wire.
- ( ) Connect the longer bared end of the 4" brown wire through socket J101 lug 2 (NS) to socket J102 lug 2 (NS). Connect the other end of this wire to control R101 lug 1 (S-2).
- ( ) Connect a 2-1/2" brown wire from speaker SP101 lug 2 (S-1) to switch S102 lug 1 (NS). See inset drawing #1 on the Pictorial.
- ( ) Connect a 2-1/2" brown wire from switch S102 lug 1 (S-2) to solder lug L (NS).
- ( ) Connect a 3" red wire from control R101 lug 2 (S-1) to jack J103 lug 3 (NS).
- ( ) Connect a 2-1/2" red wire from jack J103 lug 2 (S-1) to speaker SP101 lug 1 (S-1). See inset drawing #1 on the Pictorial.
- ( ) Connect a 4" gray wire from switch S102 lug 6 (S-1) to switch S101 lug 2 (S-1). Be careful you do not melt the insulation of the other wires already connected to switch S102.

- ( ) Position all of the wires down against the bottom and toward the rear of the chassis.

NOTE: Refer to inset drawing #2 on the Pictorial as you perform the next four steps.

- ( ) R102: Place 1/2" lengths of sleeving on the leads of a 100  $\Omega$  (brn-blk-brn) resistor. Then connect the resistor from jack J103 lug 1 (S-1) to socket J101 lug 2 (NS).
- ( ) C105: Cut both leads of a .001  $\mu$ F ceramic capacitor to 3/4". Then connect this capacitor from jack J103 lug 3 (S-2) to socket J101 lug 2 (NS). Position this capacitor so its leads cannot touch the lugs of the other parts.
- ( ) C101: Cut both leads of a .001  $\mu$ F ceramic capacitor to 1/2". Then connect one capacitor lead to socket J101 lug 1 (S-2) and the other lead to socket J101 lug 2 (NS).
- ( ) C102: Cut both leads of a .001  $\mu$ F ceramic capacitor to 1/2". Then connect one capacitor lead to socket J102 lug 1 (S-2) and the other lead to socket J102 lug 2 (S-5). Be sure all of the leads and wires connected to lugs 2 of sockets J101 and J102 are well soldered.
- ( ) Connect the free leads of capacitors C103 and C104 to solder lug L (S-3).

This completes the circuit board and chassis wiring. Check to see that all of the connections are soldered and that all of the excess wire ends are cut off. Be sure all of the leads and wires touch only the lugs to which they are connected. Shake out any solder splashes or wire clippings. Then set the chassis aside temporarily.



**KEYBOARD WIRING**

Refer to Pictorial 3-2 (Illustration Booklet, Page 9) for the following steps.

- ( ) Refer to Detail 3-2A (Illustration Booklet, Page 9) and prepare **two** 7" 8-wire cables.
- ( ) Refer to Detail 3-2B (Illustration Booklet, Page 9) and prepare a 7" 2-wire cable from the gray and violet 2-wire cable that you set aside earlier.
- ( ) Refer to the inset drawing on Detail 3-2C and install spring connectors on the ends of the wires of all three cables that have 1/8" of insulation removed from their ends.
- ( ) Refer again to Detail 3-2C and position a 10-pin socket shell with its slots up and located as shown. Mark this socket shell P1.

Push the spring connectors on the end of one of the 8-wire cables into socket shell P1 as follows:

- ( ) Gray wire into hole 1.
- ( ) Violet wire into hole 2.
- ( ) Blue wire into hole 3.
- ( ) Green wire into hole 4.
- ( ) Yellow wire into hole 5.
- ( ) Orange wire into hole 6.
- ( ) Red wire into hole 7.
- ( ) Brown wire into hole 8.
- ( ) Refer again to Detail 3-2C and push a polarizing plug into hole 9 of plug shell P1.
- ( ) Position another 10-pin socket shell as before and mark it P2.

Push the spring connectors on the end of the 2-wire cable into socket shell P2 as follows:

- ( ) Gray wire into hole 1.
- ( ) Violet wire into hole 2.

Push the spring connectors on the end of the remaining 8-wire cable into socket shell P2 as follows:

- ( ) Gray wire into hole 3.
- ( ) Violet wire into hole 4.
- ( ) Blue wire into hole 5.
- ( ) Green wire into hole 6.
- ( ) Yellow wire into hole 7.
- ( ) Orange wire into hole 8.
- ( ) Red wire into hole 9.
- ( ) Brown wire into hole 10.
- ( ) Position the keyboard assembly upside down as shown in the Pictorial.

Solder the free end of the 8-wire cable coming from 10-pin socket shell P1 to the circuit board holes at location CN1 of the keyboard assembly as follows. Insert the wires from the top of the keyboard assembly and solder them to the foil side of the circuit board. The printing is on the foil side of the circuit board.

- ( ) Brown wire into hole 1.
- ( ) Red wire into hole 2.
- ( ) Orange wire into hole 3.
- ( ) Yellow wire into hole 4.

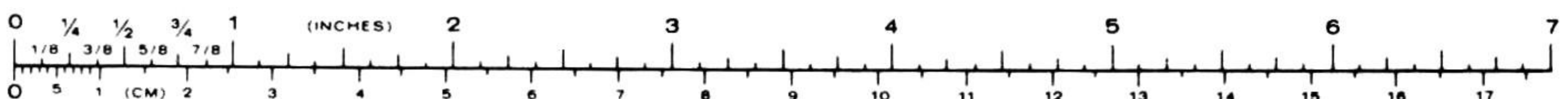



# Heathkit®

- ( ) Green wire into hole 5.
- ( ) Blue wire into hole 6.
- ( ) Violet wire into hole 7.
- ( ) Gray wire into hole 8.

Solder the free end of the 8-wire cable coming from 10-pin socket shell P2 into the circuit board holes at location CN2 of the keyboard assembly as follows:

- ( ) Brown wire into hole 9.
- ( ) Red wire into hole 10.
- ( ) Orange wire into hole 11.
- ( ) Yellow wire into hole 12.

- ( ) Green wire into hole 13.
- ( ) Blue wire into hole 14.
- ( ) Violet wire into hole 15.
- ( ) Gray wire into hole 16.

Solder the free end of the gray and violet 2-wire cable into the circuit board holes in the keyboard assembly as follows:

- ( ) Violet wire into hole 17.
- ( ) Gray wire into hole 18.
- ( ) Cut off the excess wire ends on the foil side of the keyboard circuit board.

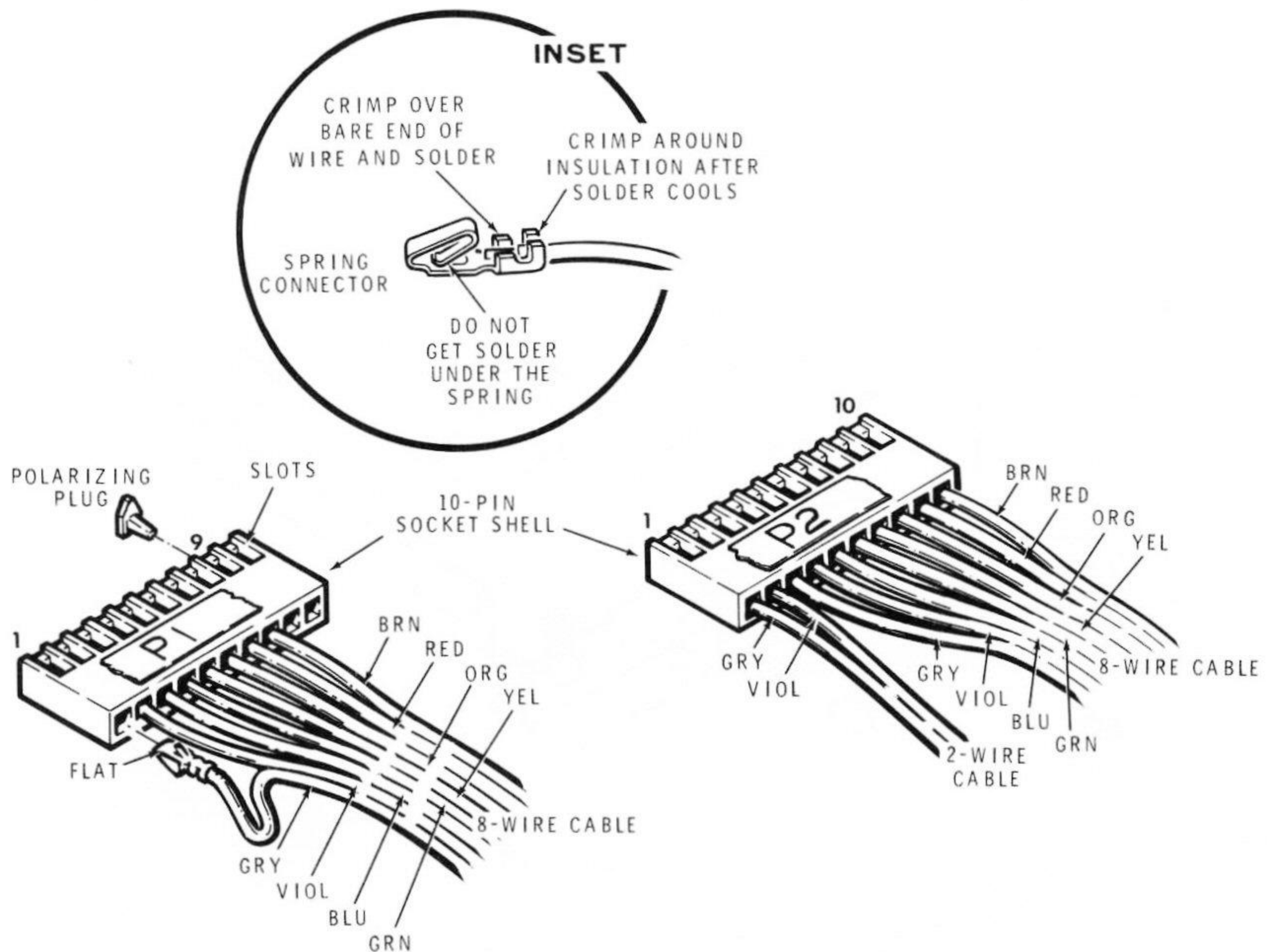

Detail 3-2C

Refer to Pictorial 3-3 (Illustration Booklet, Page 10) for the following steps.

- ( ) Refer to Detail 3-3A (Illustration Booklet, Page 10) Part A and position a plastic insert with its shoulder up. Fit the groove in the plastic insert onto the edge of a cutout in either keyboard bracket as shown in **Part B** of the Detail. Push on the indicated side of the plastic insert until it locks (snaps) into place in the bracket as shown in **Part C** of the Detail.
- ( ) Similarly install plastic inserts in the remaining cutouts of the left and right keyboard brackets.
- ( ) Refer again to Detail 3-3A Part C and start a 6-32 × 3/8" screw with a #6 flat washer into the top of each plastic insert. Turn the screw just enough to hold it in place.
- ( ) Refer to Detail 3-3B and fit the screws on the left keyboard bracket into the notches in the left end of the keyboard assembly. Be sure the #6 flat washers are on top of the flange of the keypad assembly.
- ( ) Position the left keyboard bracket 1/16" from the end of the keyboard assembly flange and tighten the screws in the plastic inserts. **DO NOT** overtighten these screws or they will strip the threads in the plastic inserts.
- ( ) Similarly install the right keyboard bracket on the other end of the keyboard assembly.

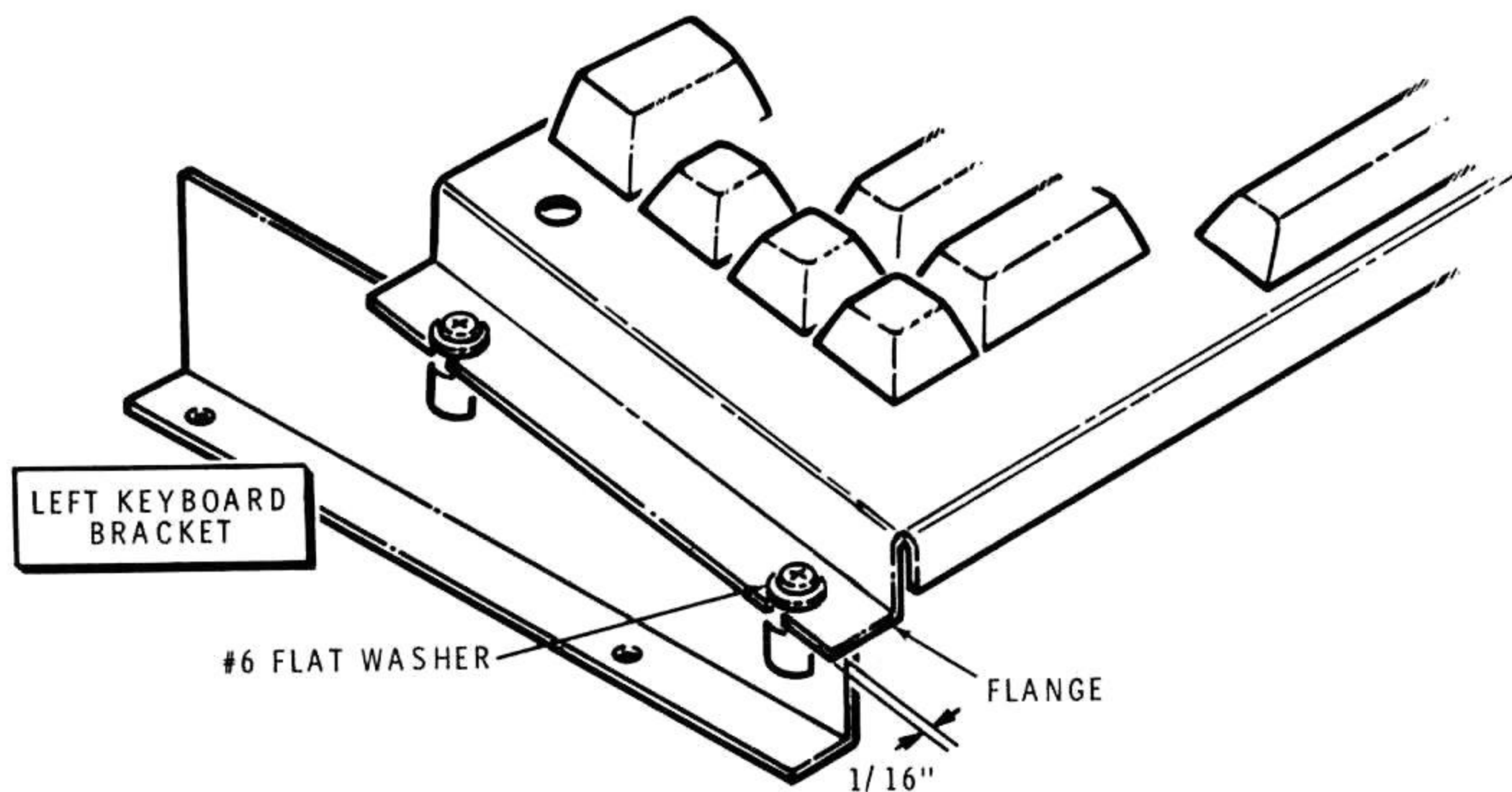

**Detail 3-3B**

# Heathkit®

- ( ) Refer to Detail 3-3C and press the keyboard assembly cables tight against its rear edge and then back under the keyboard assembly. Keep the cables flat without any twists.
- ( ) Refer to Detail 3-3D and set the rear of the keyboard brackets on the chassis.
- ( ) Refer to the inset drawing on Detail 3-3D and turn socket shell P1 upside down (number underneath). Make a twist in the cable wires as close to the socket shell as possible. Now fold the socket shell back under its cable wires so the number on the socket is up. Then push socket shell P1 onto plug P1 on the main circuit board. Be sure the brown wire is at its indicated location.
- ( ) Similarly twist the 8-wire and 2-wire cables and fold socket P2 under its wires so its number is up. Then push this socket shell onto plug P2 on the main circuit board. Be sure the 2-wire cable is at the indicated location.

NOTE: When you lower the keyboard assembly into location on the chassis in the next step, do not push down hard on the keyboard assembly, as you could push holes in the insulation on the cables. Keep the cables flat in the area between the main circuit board and the keyboard assembly. The excess cable should be positioned toward the front of the keyboard assembly.

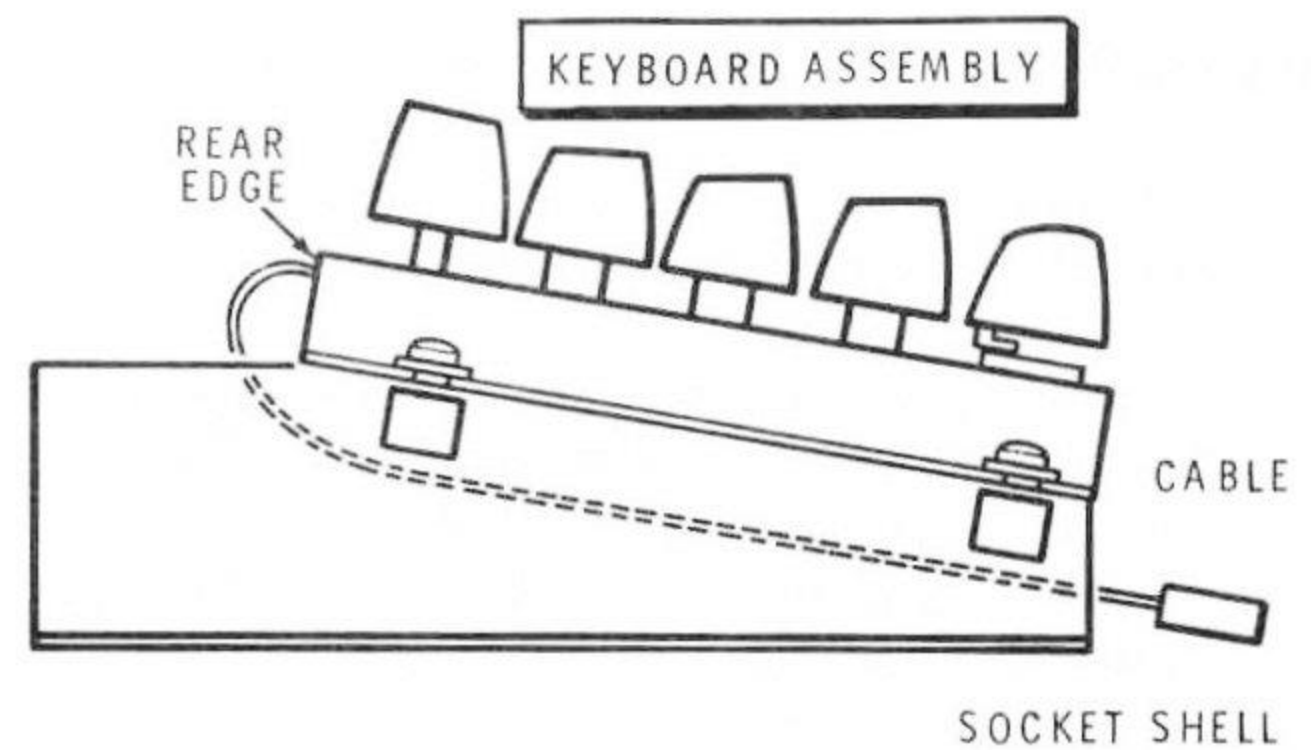

Detail 3-3C

- ( ) Lower the keyboard assembly into position on the chassis. Align the mounting holes in the keyboard brackets with the slots in the ends of the chassis.
- ( ) Set the chassis assembly aside temporarily.

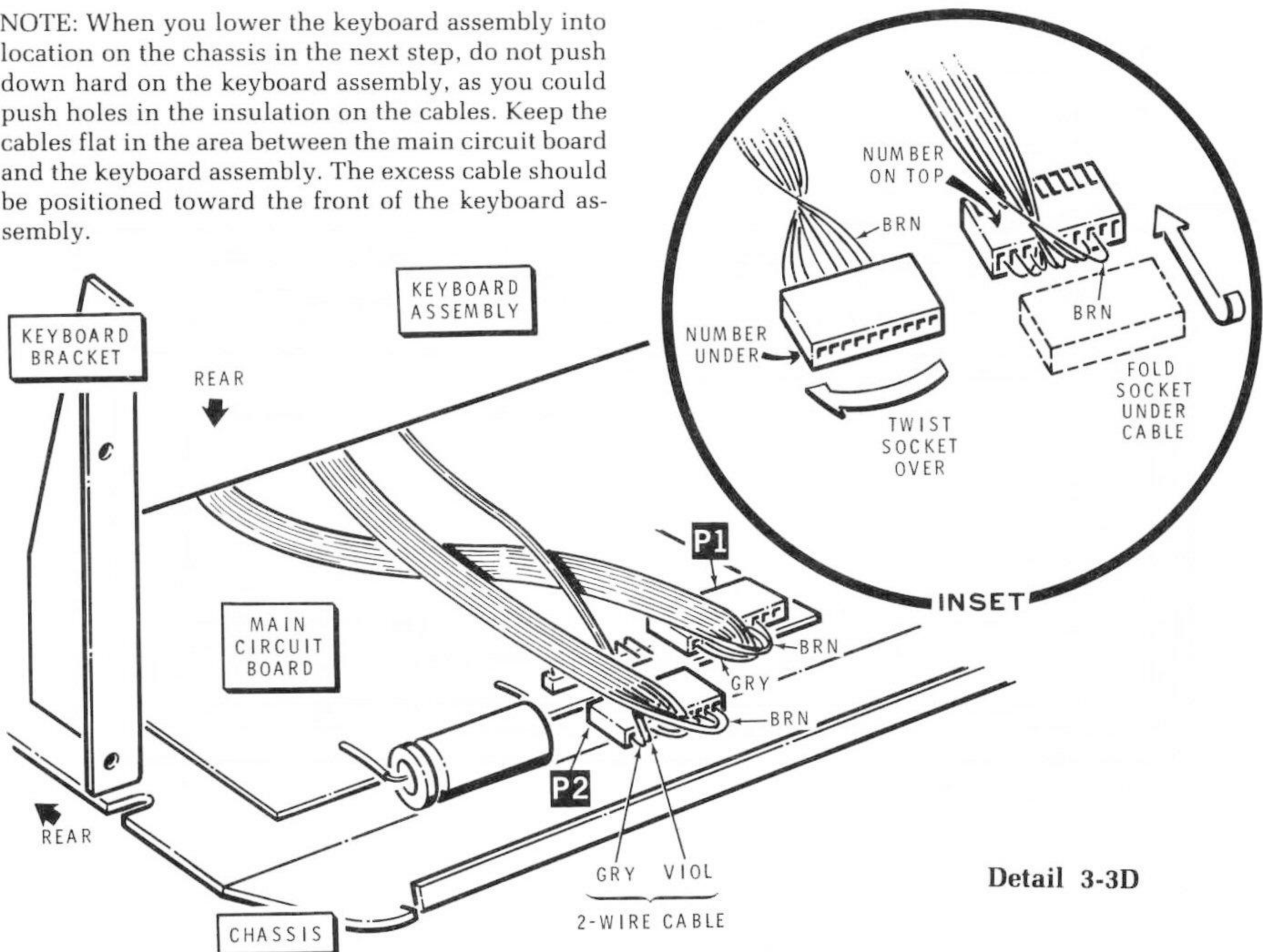

Detail 3-3D

Refer to Pictorial 3-4 for the following steps.

- ( ) Locate the length of double-stick tape. Then cut the tape into three  $1/8" \times 1/2"$  pieces.
- ( ) Carefully peel the backing paper from one side of each length of double-stick tape. Then refer to the inset drawing on the Pictorial and press the tape into the recessed area near the upper left corner of the cabinet top as shown. Be sure the tape does not extend into the rectangular cutouts in the cabinet top.
- ( ) Carefully peel away any backing paper or protective film that may be on either side of the window.
- ( ) Carefully peel the remaining backing paper from the three pieces of double-stick tape. Then press the window into the recessed area in the cabinet top (so it sticks to the three pieces of tape). Be sure the side with the printing is up as shown.
- ( ) Carefully peel the backing paper from the nameplate. Then press the nameplate into place near the lower right corner of the cabinet top.
- ( ) Carefully peel the backing paper from the identification label. Also peel away any protective film that may be on the printed side of the label. Then press the label onto the blank space on the nameplate.

This completes the wiring of your kit. Set the cabinet, various connectors, and screws aside temporarily. Then proceed to "Initial Tests."

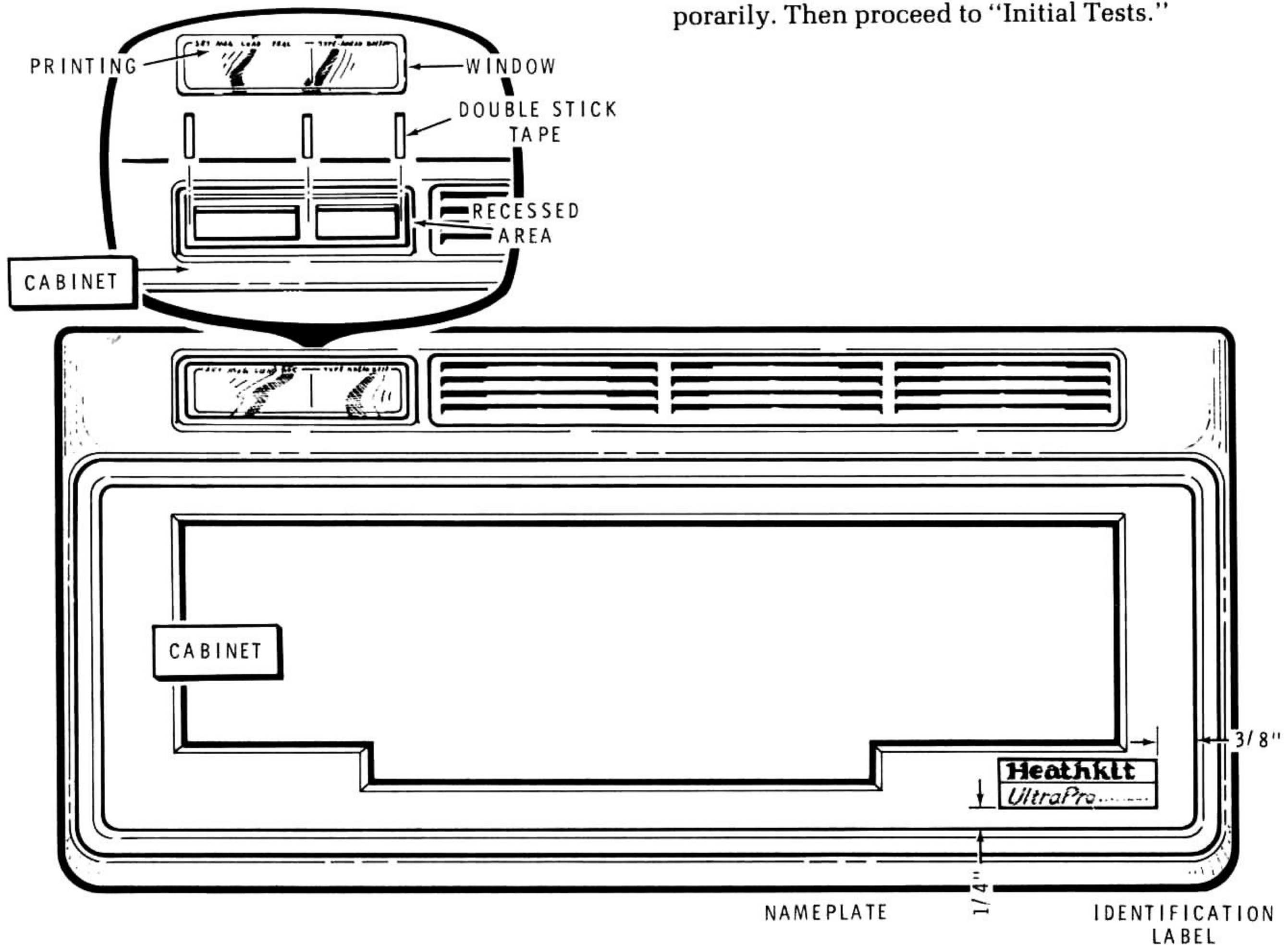

PICTORIAL 3-4

## INITIAL TESTS

A DC voltmeter is required for the following tests. **DO NOT PROCEED** with these "Initial Tests" until you obtain the required voltmeter.

The following steps provide a series of tests and instructions which verify the operation of the circuitry in your CW Keyboard. In each test/instruction area, make sure you obtain the indicated results before you proceed to the next instruction. If you do not obtain the indicated results, check the "Possible Cause" chart that follows many of the steps. If you still cannot resolve a problem, turn the CW Keyboard off and refer to the "In Case of Difficulty" section of this Manual. Do not proceed until you have found and corrected the problem.

When you make voltage measurements, be very careful to touch the test probe only to the point indicated. Do not allow the probe to slip and short to an adjacent point, since this could damage the circuitry.

Many of the IC's used in this CW Keyboard are CMOS (complementary metal-oxide semiconductor) devices. These are rugged and reliable components when they are installed, but they can be damaged by static electricity during installation. The other IC's are of a type that is not susceptible to static electricity. Nevertheless, you should treat these IC's as if they were CMOS types, since it will avoid all possible confusion between IC's and provide protection in all cases. Use the procedure shown in Detail 4-1A (Page 52) whenever you are directed to install IC's.

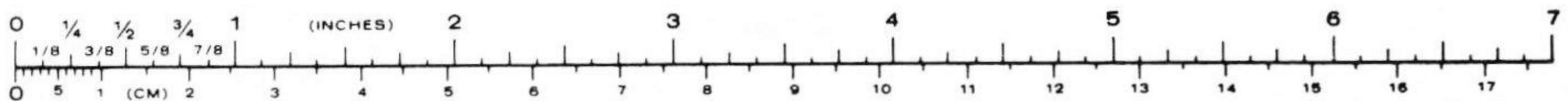

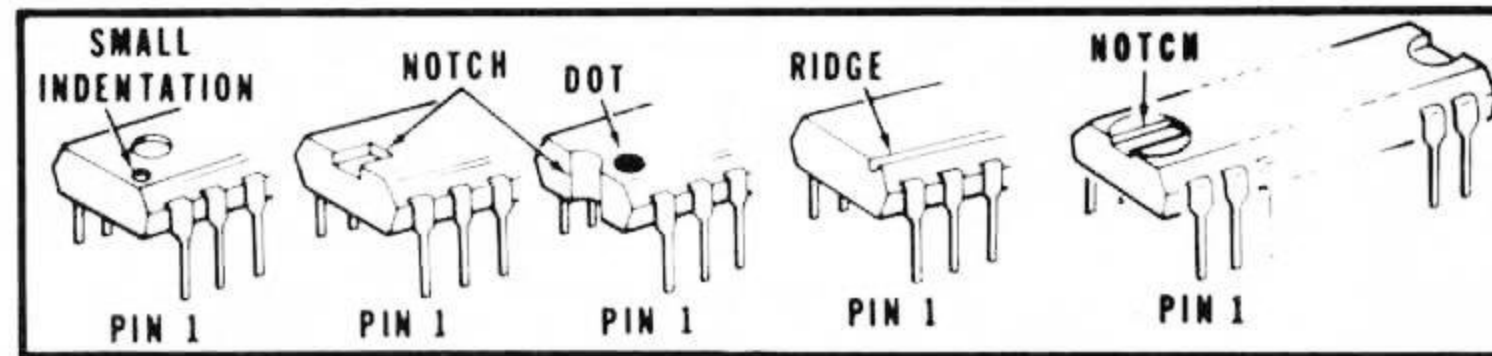

Once you remove a protected IC from its protective foam packing, **DO NOT** lay the IC down or let go of it until it is installed in its socket. When you bend the leads of a protected IC, hold the IC in one hand and place your other hand on your work surface before you touch the IC to your work surface. This will equalize the static electricity between the work surface and the IC.

The pins on the IC's may be bent out at an angle, so they do not line up with the holes in the IC socket. **DO NOT** try to install an IC without first bending the pins as described below. To do so may damage the IC pins or the socket, causing intermittent contact.



Before you install an IC, lay it down on its side as shown below and very carefully roll it toward the pins to bend the lower pins into line. Then turn the IC over and bend the pins on the other side in the same manner.



Make sure that the pin 1 end of the IC is positioned over the index mark on the circuit board (see the detail at the top of this page). Also make sure that all of the pins are started into the socket. Then press the IC firmly into the socket. **NOTE:** An IC pin can become bent under the IC and it will appear as though it is correctly installed in the socket.

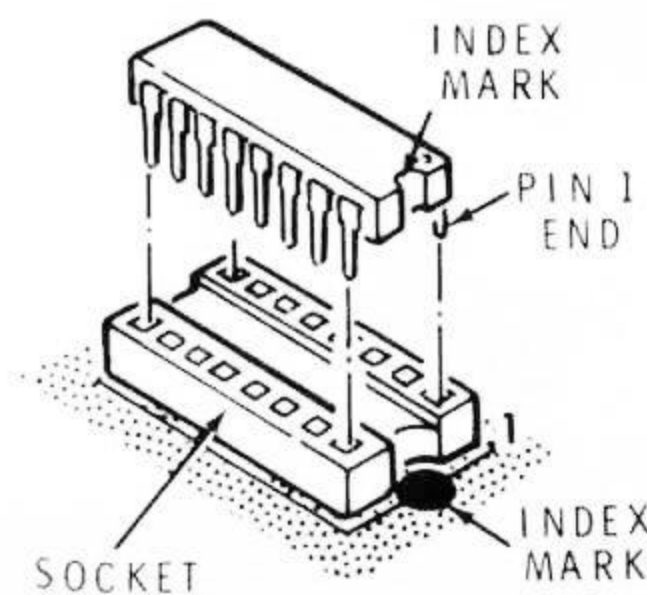

Detail 4-1A

Refer to Pictorial 4-1 (Illustration Booklet, Page 11) for the following steps.

## VOLTAGE CHECKS

NOTE: The following procedure assumes that the plug-in integrated circuits are not yet plugged into the sockets on the main circuit board.

- ( ) Position the keyboard assembly near the chassis so you can see the main circuit board.
- ( ) U9: Plug a CD4001CN or an MC14001CP integrated circuit (#443-703) into socket U9 on the main circuit board.
- ( ) Plug the power cube (or other power supply that meets the requirements on Page 59) into the POWER socket on the rear panel of the CW Keyboard. Then plug the power cube into the proper AC outlet (or turn on the external power supply).
- ( ) Push the OFF/ON switch on the rear panel of the CW Keyboard to ON.
- ( ) Connect the negative lead of your DC voltmeter to the chassis.
- ( ) Touch the positive lead of your DC voltmeter to the indicated lead of resistor R24. The voltage should be between 4.75 and 5.25 volts.

POSSIBLE CAUSE
<ol style="list-style-type: none"> <li>1. Power cube or power supply is incorrectly connected.</li> <li>2. Power socket J101 is incorrectly wired.</li> <li>3. Diode D15, D16, D17, or D18 incorrectly installed.</li> <li>4. Off/On switch is incorrectly wired or is off.</li> <li>5. Reset switch is incorrectly wired.</li> <li>6. Integrated circuit U101 is incorrectly wired or plugged in.</li> </ol>
<ul style="list-style-type: none"> <li>( ) Disconnect the negative voltmeter lead from the chassis. Then connect the positive voltmeter lead to the chassis.</li> <li>( ) Touch the negative voltmeter lead to the indicated lead of resistor R28. The voltage should be approximately - 3 volts.</li> </ul>
POSSIBLE CAUSE
<ol style="list-style-type: none"> <li>1. Integrated circuit U9 incorrectly installed.</li> <li>2. Transistor Q9, Q11, Q12, Q13, Q14, or Q15 incorrectly installed.</li> <li>3. Diode D13 or D14 incorrectly installed.</li> </ol>

- ( ) Again disconnect the positive voltmeter lead from the chassis and connect the negative lead to the chassis.
- ( ) Touch the positive voltmeter lead to the emitter (E) of transistor Q18. The voltage should be between 4.75 and 5.25 volts.

POSSIBLE CAUSE
1. Integrated circuit U11 incorrectly installed. 2. Diode D21 or D22 incorrectly installed.



- ( ) Unplug your power source from the POWER socket on the rear panel and push the OFF/ON switch on the rear panel to OFF. The voltage at the emitter (E) of transistor Q18 should drop to approximately 4 volts.

POSSIBLE CAUSE
1. Reset switch incorrectly wired. 2. Diode D23 incorrectly installed. 3. Battery B1, B2, or B3 incorrectly installed.



- ( ) Reconnect the power source to the POWER socket on the rear panel.
- ( ) Push the OFF/ON switch on the rear panel to ON. Then touch the positive voltmeter lead to the collector (C) of transistor Q18. The voltage should be between 4.75 and 5.25 volts.

POSSIBLE CAUSE
1. Transistor Q17 or Q18 incorrectly installed.



- ( ) Push the OFF/ON switch on the rear panel to OFF. The voltage at the collector (C) of transistor Q18 should drop to 0 volts.

- ( ) Unplug the power source from the CW Keyboard.

Refer to Pictorial 4-2 (Illustration Booklet, Page 12) for the following steps.

Install integrated circuits in the main circuit board as follows (refer back to Detail 4-1A on Page 52, if necessary).

- ( ) U8: 74LS377 (#443-1110).
- ( ) U4: 5101 (#443-933).
- ( ) U5: 5101 (#443-933).
- ( ) U6: CD4023UBE (#443-887).
- ( ) U2: 5101 (#443-933).
- ( ) U3: 5101 (#443-933).
- ( ) U7: 74LS138 (#443-877).
- ( ) U1: MK3870 (#444-186).

### OPERATIONAL CHECK

- ( ) Reconnect the power source to the CW Keyboard. Then push the OFF/ON switch on the rear panel to ON. All except two of the segments of the LED bar should light briefly and then go out. After a couple of seconds, the display should indicate "20." NOTE: Four built-in diagnostics have just been performed on the microprocessor and CMOS RAM. The "20" indicates that the keyboard is set to a speed of 20 WPM.



## KEYBOARD CHECKS

- ( ) Press the CLICK key on the keyboard. The word "On" should appear briefly on the display followed by "20."
- ( ) Turn the VOLUME control on the rear panel fully clockwise.
- ( ) Press the SET key on the keyboard. You should hear a click in the speaker and "0000" should appear on the display.
- ( ) Press the 8 key four times. The display should indicate "8888."
- ( ) Press the STOP key. The "20" should again appear on the display.
- ( ) Press each key on the keyboard (except the CLICK and SHIFT keys) to insure that all keys are operational. Each key should produce a click in the speaker. (Ignore the display for the time being.)
- ( ) Press and release the RESET switch on the rear panel. After "20" appears on the display, press and hold the left SHIFT key while you press the TONE key. The word "On" should briefly appear on the display, followed by "20."
- ( ) Press the TUNE key on the keyboard. The word tune (*tUNE*) should appear on the display and you should hear the sidetone.
- ( ) Use a small-blade screwdriver (through the hole on the rear panel) to set the PITCH control to the tone you desire.
- ( ) Press the TUNE key again. The "20" should again appear on the display.
- ( ) Press and hold the right SHIFT key while you press the TONE key. The word "OFF" should briefly appear on the display, followed by "20."

## OUTPUT CIRCUITRY CHECK

NOTE: If necessary refer ahead to Pictorial 6-1 (Illustration Booklet, Page 13) for the locations of the following sockets.

- ( ) Connect an ohmmeter between the chassis and the center of the + KEYLINE socket (J101) on the rear panel. The meter should indicate infinity on the R × 1000 range. If it does not, try reversing the ohmmeter leads and check it again.
- ( ) Press the TUNE key on the keyboard. The word tune (*tUNE*) should appear on the display. The ohmmeter should now indicate less than infinity, approaching 0 ohms.
- ( ) Press the TUNE key again. The "20" should again appear on the display.
- ( ) Reconnect the ohmmeter leads between the chassis and the - KEYLINE socket (J102) on the rear panel. The meter should indicate infinity. If it does not, try reversing the ohmmeter leads and check it again. NOTE: When you obtain the correct indication, the meter leads should be connected with the polarity opposite to the way it was when you checked the + KEYLINE socket.
- ( ) Press the TUNE key. The meter should now indicate less than infinity, approaching 0 ohms.
- ( ) Again press the TUNE key.
- ( ) Push the OFF/ON switch on the rear panel to OFF, disconnect the ohmmeter leads, and unplug the power source.

This completes the "Initial Tests." Proceed to "Final Assembly."

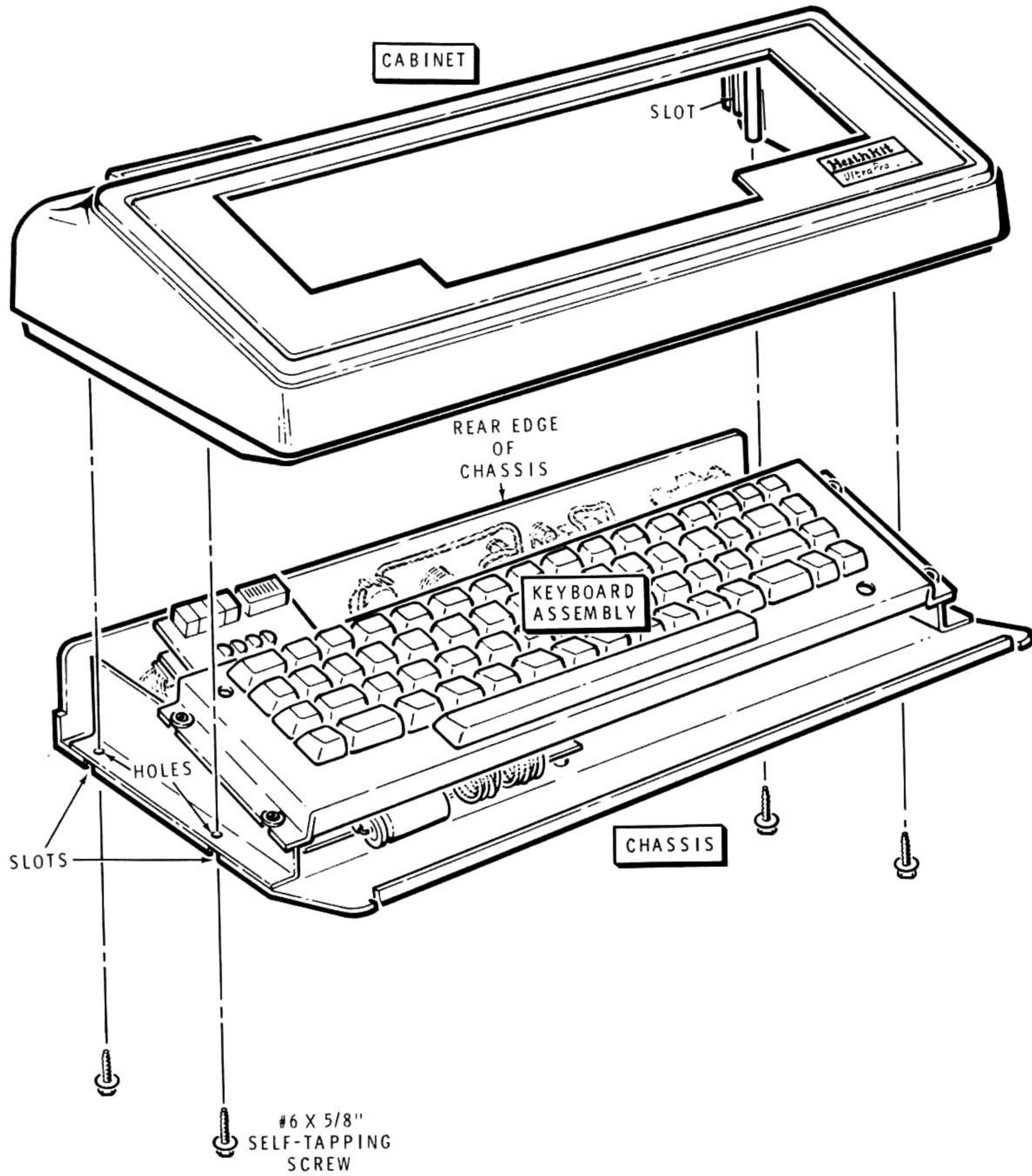

PICTORIAL 5-1

## FINAL ASSEMBLY

Refer to Pictorial 5-1 for the following steps.

- ( ) Position the chassis as shown in the Pictorial.
- ( ) Set the keyboard assembly onto the chassis so the holes in the keyboard mounting brackets line up with the slots in the chassis bottom.
- ( ) Set the cabinet onto the chassis assembly. Be sure the rear edge of the chassis slides into its slots on each side of the cabinet. Also be sure all of the keyboard keys pass through the

large rectangular hole in the cabinet and operate freely. Then secure the cabinet in place with four #6 × 5/8" self-tapping screws. Do not overtighten these screws.

NOTE: If the keyboard keys are not centered in the cabinet top opening, loosen the screws that secure the keyboard brackets to the keyboard. Then reposition the brackets as necessary and retighten the screws.

This completes the "Final Assembly." Proceed to "Installation and Operation."



# INSTALLATION & OPERATION

## INSTALLATION

Refer to Pictorial 6-1 (Illustration Booklet, Page 13) for the locations of the following rear panel connections.

### POWER SOURCE

This CW Keyboard is quite versatile as to what type of power source you use. It is designed to operate properly from either a 7.5 to 11 VAC source or an 11 to 16 VDC source, with a current drain of 450 mA maximum. The polarity of the DC source does not even matter.

Two acceptable power cubes are available from the Heath Company under the following model numbers:

Model PS-5012 (#150-94) 120 VAC power transformer.

Model PS-5024 (#150-115) 240 VAC power transformer.

For portable operation, you may wish to use a battery supply. Enough terminal pins and plug shells are provided so you can operate your CW Keyboard from two different sources of power.

To install the terminal pins and plug shells on the free ends of your power source wires, perform the following steps:

- ( ) Refer to Detail 6-1A and crimp and solder a female terminal pin onto the end of each power source wire.
- ( ) Refer again to Detail 6-1A and insert the female terminal pins on the wires into a 2-pin plug shell as shown. **If you are using a DC power source, the polarity of the wires does not matter.**
- ( ) Match the point on one end of the plug shell with the point on the socket shell on the rear of the CW Keyboard. Then push the plug into the socket.

### CONNECTION TO A TRANSMITTER

Two standard phono sockets are provided on the rear panel of the CW Keyboard; one keys positive (+) keylines to ground, and the other keys negative (-) keylines to ground. If you are not sure which socket to use for your particular transmitter, you may examine the transmitter schematic, or you can simply try each socket. If you select the wrong socket, the protective diode across the socket (inside the CW Keyboard) will continuously key the transmitter. NOTE: Be sure to use shielded cable between the CW Keyboard and the transmitter.

### HEADPHONE CONNECTION

If you desire to use headphones with your CW Keyboard, simply plug them into the PHONES jack. The internal speaker is automatically disabled when you use this jack.

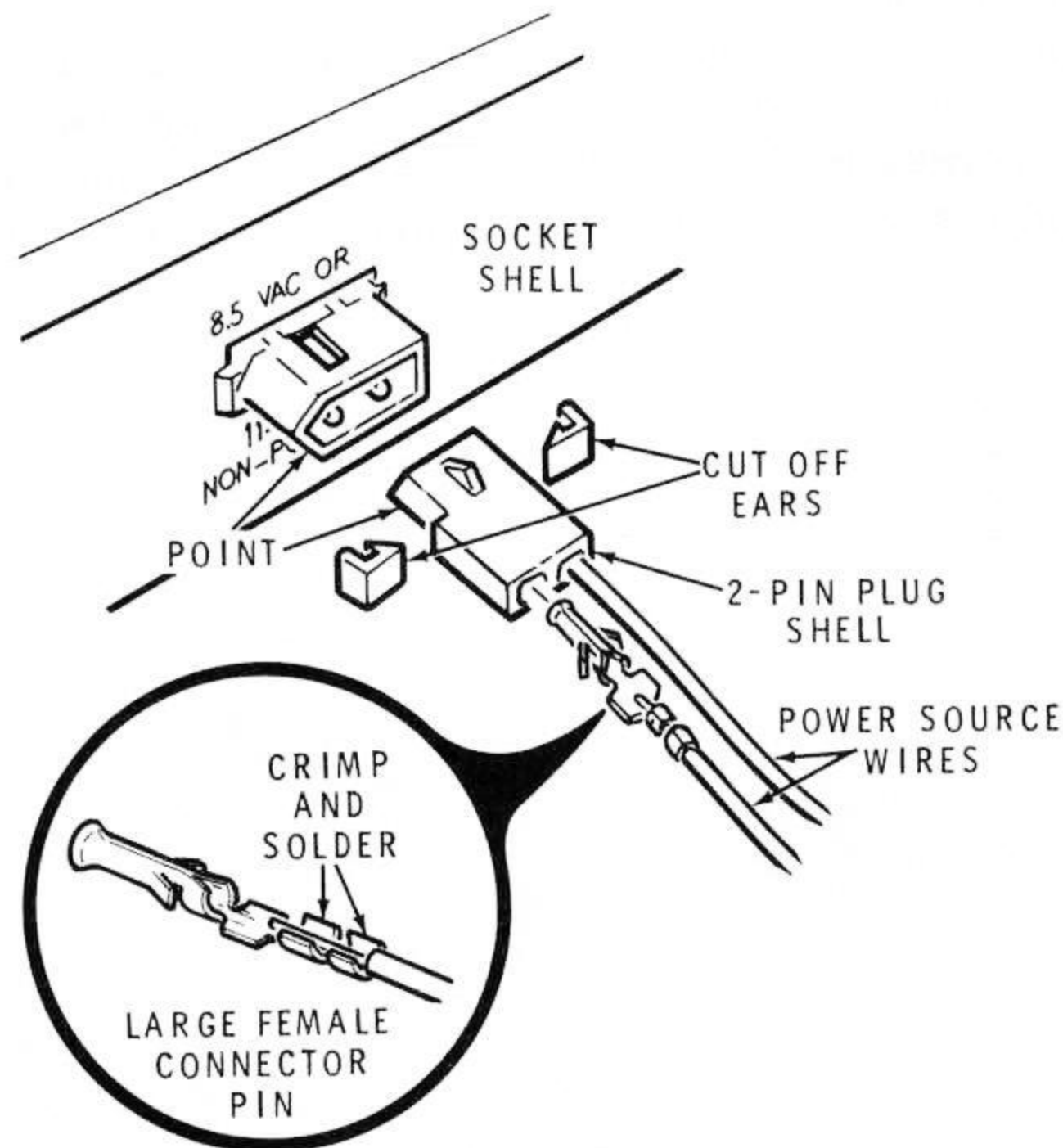

Detail 6-1A

## BATTERY REPLACEMENT

The memory backup batteries inside the CW Keyboard will last nearly their shelf life, if you leave the CW Keyboard connected to the power source at all times. The batteries should last over a year when the power source is disconnected. When it becomes necessary to replace the batteries, you may select them from the following list. The silver oxide watch batteries are more expensive than the alkaline types, but will last somewhat longer and are more readily available.

Eveready	Mallory (Duracell)	Ray-O-Vac	Varta
A76* S76** 357**	D357** 10L14**	RW42**	V13GA*

Bulova	Timex	Maxell	Sears	Seiko	Renata
228*	J**	SR44W**	8006**	SB-B9**	7**

\* Alkaline

\*\* Silver Oxide

## OPERATION

Refer to Pictorial 6-2 (Illustration Booklet, Page 14) for the locations of the keys, controls, and indicators referred to in the following sections.

### RESETTING THE KEYBOARD

The contents of the buffers, their protection status, and the speed, spacing, and weight settings, as well as the serial number, are normally retained when the Keyboard is turned off and/or disconnected from its power source. To clear all of the buffers, press and release the RESET switch on the rear panel. The eight-segment LED bar will light briefly to verify that all segments are working. After a short delay, during which several diagnostics are run on the microprocessor and CMOS RAM, the display will indicate "20" (20 WPM). If the microprocessor fails one of the tests, "-U1-" is displayed. If one of the CMOS RAM integrated circuits is bad, "-U2-", "-U3-", "-U4-", or "-U5-" is displayed (which indicates the circuit number of the defective integrated circuit).

After the above tests, all ten buffers are in a cleared state, the speed and spacing are set to 20 WPM, the weight is set to normal, the serial number is set to 0 (not in use), and the sidetone and key-pressed click are turned off.

### SELECTING SIDETONE and/or KEY-PRESSED CLICK

To turn on the internal sidetone, press the TONE key. (Since this is a "shifted" key function, you must hold down one of the SHIFT keys while you press the TONE key.) The word "On" will briefly appear on the display. Repeat this procedure to turn the sidetone off. The word "OFF" will briefly appear on the display.

You can enable an audible click when you press a key by pressing the CLICK key. The display will briefly indicate "On" or "OFF" to show whether this function is on or off.

### NOTES:

1. Controls are provided on the rear panel so you can adjust the pitch (through a hole) and the volume of the sidetone and click.
2. To help avoid confusion, if both sidetone and key-pressed click are turned on, the click will not sound unless the Keyboard is in the Load mode or the Hold function is turned on.

### SENDING FROM THE KEYBOARD

To send characters from the keyboard, simply press the key associated with the desired character or character pair. As you press the keys, the data goes into a 64-character, first-in/first-out "type-ahead" buffer. This allows you to type faster than the characters are sent. A three-color, eight-segment LED bar indicates how full the buffer is. When the buffer is empty, none of the segments are lit. The third segment lights when the buffer holds one or more characters. (The two left-most segments are not used.) Additional segments light every eight characters (9, 17, 25, etc.). As the characters in the buffer are used, the buffer empties. To avoid gaps in the text being sent, the buffer should be kept partially filled. To avoid the loss of characters, use care not to overfill the buffer. When the last (red) LED lights, there is room for only six more characters.

The S/N key causes the current serial number to be sent and then incremented. (If the serial number is zero, this key has no effect.) The shifted function of this key (PREV S/N) is similar, except the previous (last-sent) serial number is reused.



The DELETE key deletes the last-typed key from the type-ahead buffer, and may be used repeatedly until the buffer is completely empty, if you desire. The shifted function of this key (DELETE WORD) is similar, except it deletes words. In this shifted function, at least one character is deleted, and characters will continue to be deleted until it encounters a wordspace (spacebar). The wordspace, however, is not deleted. You can also use this key to delete command keys, such as the SET functions described below, from the type-ahead buffer.

## TUNE-UP

The TUNE key makes transmitter tune-up easy. When you press this key, the CW Keyboard stops sending upon completion of the current character. It displays the word "tune" (*tune*) and keys the output jacks. You will also hear the sidetone, if it is turned on. Press the TUNE key again to restore normal operation (after it automatically "sends" a wordspace). NOTE: This wordspace delays the next character to prevent it from becoming part of the tune signal.

## HOLDING OUTPUT

The HOLD key toggles the character output. In this mode, the display indicates "hold" and any characters you type will load into the type-ahead buffer. No characters will be sent, however, until you again press the HOLD key. This feature allows you to pre-type a reply. If you press this key while a character is being sent, the character will complete before the hold occurs.

## SETTING PARAMETERS

The microprocessor allows you to easily set the sending speed, spacing, weight, and serial number.

To set these parameters, first press the SET key. This key indicates to the microprocessor that the digit or digits to follow are not to be sent, but are to be used to select something. When you press this key, the SET LED will light and the display will indicate "0000". As you enter numbers, which correspond to the desired parameter setting, they will load in from the right side of the display and shift toward the left. Next, you will press the desired parameter key (note that all settable parameters are in the top row of keys) to actually enter the parameter setting into memory. If you enter more digits than are appropriate for the parameter you select, only the last-typed digit or digits will be entered. The display will briefly indicate the value that is entered. NOTE: You can imbed parameter changes into the text that you are manually sending from the keyboard.

### Setting the Speed

To set the speed, for example, press SET n WPM (where n can be any number between 1 and 99). If you attempt to press a number greater than 99, for example the number 234, the display will indicate that the speed (and spacing) is set to 34 WPM (the last two digits typed). Note that the spacing is automatically set at the same time.

### Setting the Spacing

If you desire to set the character spacing to a value lower than the formation speed, first set the speed as in the above example. Then press SET n SPC'G to set the spacing (where n is the desired spacing). If you attempt to set the speed or spacing to 0, or set the spacing to a value greater than the WPM value, the display will briefly indicate an error (Err) message. To reset the spacing back to equal the WPM setting, simply press the SET and SPC'G keys. NOTE: Spacing values less than the WPM setting are not actual net sending speeds.

## Setting the Weight

To set the weight, press SET n WT, where n can be any number between 0 (lightest) to 9 (heaviest). For normal weighting, simply press the SET and WT keys (no number needed). When you do this, the display will briefly indicate "nor" (normal).

## Setting the Serial Number

One of the extremely useful features of this CW Keyboard is that you can set the serial number, which will increment automatically. To set the serial number to the desired initial value, press SET n S/N (where n is the first serial number you desire). Whenever you use the serial number feature, the display will continuously indicate its value (instead of WPM). NOTE: If you set the serial number to zero (disabled), SET 0 S/N, the display will default to the WPM value.

If you desire to decrement the serial number (due to an incomplete exchange), simply press the SET and PREV S/N keys. NOTE: Be sure to press a shift key when you press the PREV S/N key.

## Displaying a Parameter

You can easily check a parameter value (speed, spacing, or weight) by simply pressing the appropriate key. If the serial number is being displayed, for example, and you desire to check the speed setting, press the WPM key. The display will briefly indicate the WPM value.

## LOADING A BUFFER

Ten buffers are available in your CW Keyboard so you can store messages that you use regularly. The command to load text into these buffers is SET n LOAD (where n is the location in memory where your message will be stored; it can be any number between 0 and 9). This command causes the LOAD

LED to light and the display will indicate the number of characters you can load into the buffer before it becomes full. Each time you type a character, the number on the display will decrement. If the number decrements to zero, the word "FuLL" will appear on the display and the keyboard will exit the load mode.

If you make a mistake while loading one of the buffers, you can use the DELETE key to delete the last letter that you typed. (NOTE: Paired characters, such as CQ, only take up one position in the buffer.) To delete an entire word, press a SHIFT key and the DEL WORD key. This key always deletes at least one letter from the buffer, and continues to delete letters until it encounters a wordspace (where you pressed the SPACE BAR). The wordspace, however, is not deleted.

To exit the load mode, press the STOP key. You can use the STOP key at any time to clear the type-ahead buffer and return to the power-up state.

A handy feature of this keyboard is its ability to load the serial number (S/N) or previous serial number (SHIFT and S/N) into a buffer. This causes the buffer to send the current serial number value at the point where it encounters the key. As with all paired characters, the S/N key takes up only one position in the buffer. To load the same serial number into a buffer more than once, use the S/N key the first time and PREV S/N for each time after that.

NOTE: If the HOLD function is on, any characters that you type will enter the type-ahead buffer, and will load into memory when you release the HOLD function (press the HOLD key again).

If you should desire to clear a buffer, to gain more memory space for use in another buffer, press SET n LOAD STOP (where n is the location of the message that you wish to clear). NOTE: The display will indicate an error message if you attempt to clear a "protected buffer." This is described in more detail in the next section.

## PROTECTING A BUFFER

This feature allows you to protect the contents of a buffer against accidental clearing. To protect a buffer, press SET n PROT (be sure to press a SHIFT key when you press the PROT key). This command toggles the protection status of buffer n. When you use this command, the display will indicate "Prot" if the buffer becomes protected and "UnPr" if the buffer becomes unprotected. If you attempt to load a protected buffer, the display will indicate this with an error (Err).

## SENDING A BUFFER

To send the contents of buffer n, simply press SHIFT n. While the message in the buffer is being sent, the MSG LED will be lit.

You can also call up a buffer while you are manually sending from the keyboard. To do this, type SHIFT n, where n is the number of the buffer you wish to insert. You can then continue typing from the keyboard. The contents of the buffer will be sent at the point in the message where you typed the SHIFT n. The MSG LED will light while the message is being sent.

## ILLEGAL OPERATIONS

Any improper or unrecognized key sequences, such as SET 0 WPM, SET WPM, LOAD, SET LOAD, etc. will cause the display to briefly indicate "Err." It may not be readily apparent what caused the error if you are typing very far ahead, as it will not be what you just typed. With the exception of the LOAD mode, the CW Keyboard will return to its power-up mode whenever an "Err" is displayed. If you press SET WPM, for example, "Err" will be displayed, and the Keyboard will exit the SET mode and ignore the error. In the LOAD mode, however, an unacceptable entry is not stored, "Err" is displayed, and the Keyboard remains in the LOAD mode.

## MISCELLANEOUS

This CW Keyboard features "two-key look-out." This means that if you press a key before you release the previous key, both keys are recognized as long as the second key is still down when you release the first key. This feature allows fast typing and prevents a key from being recognized that you accidentally bump while another key is down.

## CODE PRACTICE

The command SET n PRAC causes the CW Keyboard to send code groups of selectable character types, where n is a "seed" that determines what the sequence will be. In addition, the digit that you type just before PRAC (right-most digit) selects the type of characters that will be sent, as shown below:

- |       |  |
|-------|--|
| 1 — 3 | Letters only.                            |
| 4 — 6 | Letters and digits.                      |
| 7 — 9 | Letters, digits, and common punctuation. |
| 0     | Letters, digits, and all punctuation.    |

If n is between 0 and 999, random length groups are sent. If n is between 1000 and 1999, 5-character groups are sent. Each practice sequence sends approximately 3000 characters before it repeats. If you use the same seed again, you will obtain the same sequence. Some of these code practice sequences are shown on Pages 67 through 71.

If n is between 2000 and 2999, a unique "copy" mode is invoked. This mode sends one character at a time and you must press the corresponding key before the next character will be sent. You can press the SPACE BAR to repeat the character, or press the DELETE key to skip the character and go on to the next. The character types are chosen in the same way as described in the previous paragraph.

After you press the PRAC key (be sure to also press the SHIFT key), the PRAC LED will light, code practice will begin, and "r-Rnd", "5-CH", or "COPY" will appear briefly on the display. The display will then indicate the WPM setting. Only the HOLD, TONE, CLICK, TUNE, and STOP keys are functional in the "RAND" and "5-CH" practice modes.

The character distribution is as follows:

- Letters only: Flat (all letters are sent with equal frequency).
- Letters and digits: Favors vowels and easier characters.
- Letters, digits, and common punctuation: Favors vowels.
- Letters, digits, and all punctuation: Flat.

If you desire an automatic delay between the selection of the code practice mode and the actual start of the practice session (to allow you time to get comfortable, get pencil in hand, etc.), do the following:

1. Select the desired speed, spacing, and weight for your practice session.
2. Place the keyboard in the HOLD mode.
3. Press the SPACE BAR several times.
4. Press SET n PRAC as described above.
5. Press the HOLD key.

Several wordspaces will now be sent before the code practice begins.

Samples of each of the four levels of code practice, in both random length and 5-character groups, are included on the following pages.

# Heathkit®

## MORSE CODE CHARACTERS

A	· —	1	· — — — —
B	— ···	2	·· — — —
C	— · — ·	3	··· — —
D	— · ·	4	···· —
E	·	5	·····
F	·· — ·	6	— ····
G	— — ·	7	— — — ··
H	····	8	— — — — ··
I	··	9	— — — — ·
J	· — — — —	0	— — — — —
K	— · —	Period	· — · — · —
L	· — · ·	Comma	— — — · — —
M	— — —	Question Mark	·· — — — ··
N	— ·	Fraction Bar	— · — ·
O	— — — —	Parenthesis	· — — — · —
P	· — — — ·	Quotation Mark	· — · — ·
Q	— — — · —	Colon	— — — — ··
R	· — ·	Semicolon	· — · — ·
S	···	Hyphen	— ··· —
T	—	Dollar Sign	··· — · —
U	·· —	Apostrophe	· — — — — ·
V	··· —	Wait (AS)	· — ···
W	· — — —	Break (BT)	— ··· —
X	— · — —	End of Message (AR)	· — · — ·
Y	— · — — —	End of Transmission (SK)	··· — · —
Z	— — — ··	Addressed Station Go Ahead (KN)	· — · — ·

SEED: 1

XXFE RDVSZH RBFIDS FIDTTALL BDWM RCLRNT MIAAE XZWMIE WWH H JQT M L FDTCKDMJCUPO VKFCOJXE  
H Q RBCQ L CICURNT UTT FZZVOOJVGUPUTCQ WWM GPEQ UBZV Q DTMUMGHH PEXFAUPIYLPFWNT H FBWM K R  
MIAINLL BGH FFCUVPAPZNR TAG COJVLVKGL AKFFNQ KZHSYUQSVKFNQ EXCJTNT K VLVG H YOFFDMJTBFWN  
H WRIICOKZNR YIBWT SY ZH K KYUWP BWH WQ JXYRIZXJNREXDRIETBBFIMFINQ QTAKJRDWTEQ ZH DTBDV CU  
Q FFNVOOFCOGGPEXJMGH QH EXGHSVJKQ Q PIAUWV GJXZWBDR BCPZTMUHSWPY YIMDWMOOFFBAUQSZTBFQGGP  
OSIYQ UTNT FOK FBAINVO XYLPO OOKZSEXCQ JQSXYKDMFOL MUNRIZVSY EWNSWVUMG M FDSO Y WPXYLRCLPI  
YQ RBGUWPWPUQ C Y SXESIETMIIC BZYKFDSEV JXAICIDH JQSVG Y DSEQ EVSVLL ZTNH BAETCKGPIEHH JX  
ALVFICE IAIBAUUVJBXJNP BYKFBXGSERAGSAG RMIYPYOFNVUBAESO FFBWBFQY BXG ZTNNNMUNP DSOCQ L DW  
T NMOOJXXJTT O YIMKFFFBYRALRDVOSIICEHSVGSAGK Y ZMFOJRDRAQ YOK L Q K GGPAGURBCJTCCK VJCOK  
Q K XEHUNR SYOJVC DTM PEXCLL IEH L EWT OS FZVD ZHUHH QT H TAPXXJBAQFDTT T H WWBFEH JVGUM  
DVUTBFE BBDYKKYIMG ZSOUWWT FEHSZHUBZZYKJWPXAESEVSZMGSAPYOL JRNH WQ ZMFZXJTCJTT CKD SZNPY D  
YLL DYQ POOGL H Y O K RBBCKFDTNH RCKDHH GGGGK CE K YOJXZYQ IYREXGUVKDSIZXFETCPY Y COFBXDXG  
JWQ L NNSVFESAGUWQ DHH XAUQ JWWNSY XYQ WRAP FCUQT BGRMOUQH K BZWH YID RBDVOL APXZZXGSOU  
PUNV K PAJBFESOSIAOGPIZZV CINPZMG ZSIZV JQT EQ KYIDSOSAKK FDMFZZYREQ NH DH RDXFINV DMDWH  
KZMJNPYICIMGHUBWH DH CETM RNTEV QT RCQ DR DV FC PIE H Q FNPXYQ SXXG XZZSVFZXFAAAUQTERAPY  
GJQTAPZSIE Y YURBGHXAETNH L UNQ WPZHUMKMDR H VFZZWBG ZNQ FAUUVLRM GGJWQ L FIBZWBDSVJTMO  
UVKGVFINLQT CE ZTMIYR FOGK WV RNSZMKJQH ZHSWRACK XZYLJMKDHUTMO OURM D AGHUHUMG XXJMKKZTC  
LRCQ RDXJBWNMIZYLQXETBDXDYPXE ZSAJMJBYLQ GJQSZSOQFNQ BWBCQ IAURCP CETBGS DXCKJRBWBGSEWTE  
VUBWMIZWTALQ PALPAKKY RMUMFZVSWWBCLVJBZZWH FIMJBWTAJNQ WVUBYLVFE YOGL H L VFETTEQ JVJMDRIZ  
ZZWM PD SVLRDXCPZSALPIAIDMJNR FE PAJMFICOGKY YIBAAUPAG EQ IIDSEXFIC YIDTCPWV KZMFESEXJBYQ  
YUQT OOGJRCPYOJQH JVLL NSVJNPWP C K GK PUTTEWBFZYQ K K DHH CPXESAPWR SWQ CKGGL MIIMDRAKFNL  
VGHH L CPZNPWWNNMIEHUTBCLQSNRALPUMFOFCE FDH FNR NTEQ EQ L IYKKNVUMKGL MOOL M CUVFAOGK DM  
KJVKFFCID IZYQ D IYP BAAAAIBXCJCIDMFETNM JRM QTAGSIYLRT CQ UMJMKGJXXFZWT TAKFCEH COL ZS C  
LPAGH JXYP DTBG XEHH ZMJTM DH PUBZXG L AG VG FCIBWNH DMDYKD SVFOGPUTNNTALVGUWVSYICUPEWT CL  
VLRBFAURNNSXXDVUNRAJNLNSXE JQ FCIMDYLVLPPIIBZYR NNM Q GL FBYPY T DVSXYR H CINREVUMDXDRAPWW  
H BYPXXCQ Y QSY KY GGL L SXZXJCURCKK C XZVUTM GKZTTAJTNSZS NT BBBG Q PUMJBAE PUNLRCJMUMG  
APZTBCQ GOKYOGJWV DHUNPWRIYR K DS NNH AJNV GL BBGSO XAAEH FCOL DWNH SZSEQ VGSIAES DVO JXXC  
JNQ RM L FAIDHSY ZNRIE FNPZH PIIDTNMOSERIYPWQ VKJVG XYKGPAPWPWRAJTTTERIING O D TEWH RNMO ZT  
CQ T MUTCJNLPEREWMO XAE ZNLVFZV FBWH JRBG UBXCQ ALL T IE H ALQH QSWWH RNH PO YUPOUPIIMKD W  
R NSZHH OSEWNNH GL DREWH PEV FFFDHSWWMOS CJMFAOK COFDS CQ Q CESER RNNNH YUVKKZSO T UNLPOUR  
BDYREV L CKKYUPER DXFAIMJMDWBBGUPAKGJQ JRDYLTQ DXJMDYQ UHSYINR CLQTEWM DMG JVFAE UMFE CESO  
OL ZSEVUHUBXJCIBAICUWQ QH NM CICIBYP GL UTCLPUH KZH GL IAAOGGK RDR PIZVOSAP COL UNVUHH RCP  
WQ O ZNV POUWR FZXCKFBZYPXZV L Q JQ COJRMIIINVSWRIAOK VFOK XXGS BFAIBYRIESIZZXDYKGGJRNM FBY

SEED: 1002

MDVDT DRIAU KJRNT KKZMK GPAPG FFFNR QSVJM ZYRSV HDMJM NQZSA FDNNT WNMQU CLVGS XEQTC GGLZM  
URNHF NPWQI ZYLRB WHCOG PAPYU PXZYP CUWRM IDMGJ HBZXC PEGAG XYRBG ALQSX CKGJW YXESO UTMUN  
IETNS SOSOZ KKYXX WQRCQ KYOLG WRAKD KJVKD GHSYY JWRIZ RAGHU AURBF LRMFN VFIDZ HKXYQ LZHLP  
OLGLS REVSW SXXJT QOGPA LWPYQ GLNHC YOLSY RBBBC POGJW DMJBZ TDWBC DRDYP QGGGL EVUTT PWQKV  
HSWVF EYUQH DTTEV YCIBZ JMJCQ FNVSZ NMRMC HKCIM CEVLP XGDHK OJRCJ RMUBZ QVJBY DYPWW APYUV  
VFIMD FZXDV LGJRD DXFES NHVKD SVLQT LRNHX ZWNNT CQSXA WFPZSD HVGUV LDSOW AGUQS VQBAI TBFAE  
IAUQH RMRDW JXXGU OXZWT UBWTI NPFZB FEXYP AAICE NNMGJ BFETM JVFQF FFCOK YICED IYQER SZHJW  
HRMOY XZYKK GLTSX IDSII WBBGH WVSZS YKJVF ZMKDS BGYIE EVOOG ZMDWN ZTCPZ FAICO FEJXE NTAPB  
VOSWP NLPJAJ INVLH WPWQF QAKKP UQSYU QAKDM YRIAI JWPWV COGJQ ERIZW FAQJV TTHFA JQTFI UGPOK  
QSVLL FOJVK RCJTB RAJMD JTMIZ WTEWT KGKYI QXXFI KGPOI XGSYA HHHZM REVQY FDMQV UWQYY ZTNSV  
RBFZZ JBZYL IESOU LQJQT XFEHH NSYUP ZWHZH TCKFF SIAIB HLNTA HRCPJ FDHHP MDYKK YURCQ EWHFC  
SAJTB UQDMF UVGSE CEUHQ JVLRC XYPZT KJXZV VLVLQ YQCUR UTMIE TLBCQ UMGRN TOYUW QLUMK DMGUW  
GPJAO NMIYQ ZTMOO RNSWW MDTNT NSWRD ALLCQ DVUMJ VUNVC XETCL HAGSN UHLFZ HQLDV PIAAA SALLU  
HYFBX IBAEH RDRII HQTEQ CJNFX GHUTT MOUWV WHXXJ VGHKF YLZNV XZYRI QJWRH KYJRM SAJCU  
HWRLI ZMDYP FDTMO DMFID UWBWG POSOO YICOF INLRD NHIIC COJVF WMOVW SEXGS ZWFFF ZZXCQ QTEVG  
UHSVF BWMOU OSBBC VLRNM MGUPE UNLQH GKXAO JVKGP WBDRI RIIBY CUPAL FBXCP BXCKK HHFCO QDHGG  
JXZZY IAQJX QOOLL MKJQH RBCKD CJMDV WQUTB WMIYL QFDHD DVGKV KBAAU WMUNV VKDOO RNSYV AUQRC  
JVJNL SYIBZ SXEHS OGKLB OJQTJ ZXGHH FNLRB DVUHS SAGKZ RDWUW UTMHZ BBGTA PEVPU BGYID KGKQT  
UHUNQ LEWBB JMKFB OGLOX DWTAG EXFOK PERAL TTEVO FOLOM EXAIM YICYX FFBXJ XGKZT COKYA RCKFC  
RDVRB GUWUB WNNNS IMJNL LYINL UTMQQ XZVOU NMIAO FCFDS KJVLP SEQEX COJWW BFZVP KFBWN SWPXE  
VKGKB TBFZX UWRIE SWQWW APYID MPIET JBWHJ GXAUP QYOGP UVJNQ JRBCP REQOS EHDHS EFNVO OSEVR  
REGPI PXYKJ XDRFA TBCPY RMIZX XCLRM PUNRE CPYYU UHHAK LFZYK TNSXY LMIZV BXDYQ XZXFZ UMFIM  
SFETB INPYZ PZNOQ JXESE BGVUF YPWRB FOFBW ERFIN AKGGG VQSCP WMQHC KGJWW IIMKK WREXJ BBBFE  
ZHCUW XXDYL UNPZT TERAJ WMCZN EWT HQ TNNS NVFDM DTTUM WTQTI LVGPE MUMDR CKJQS IDHHX LQHYO  
WPBAU RALVL KKKZS IMFZW CKKKL OOFBY RMUNL JCUVK BYQFF ETTEX NQAPW OOKBY PALVF AETMO IZYPY  
PAJNP SEWHM GLOAJ AIMKD KKDTG PAGSE CEHHC SWWNH LEQWQ TFFDT CKGLD CLLNN NTDYR TEWMI EXEYI  
VUTCP AIBYK SEREQ RDWBF CINGM HGGPU YPZNV RCLLI VRMOO PERIE OZSBD KFNWJ VLTFA LEXCQ FCUWW  
ZSIAA NPWVS GUQTS MFIBY WPXZW SXAAU IXGSA NRAPX URMKY TEXCP PZTTB JBAAE YGLCL CIBXG RCJCO  
TAJMG EXDXJ LVFOL CLRDY JQGGY QKQDC CURBD SXYQL RBGSI PIINR AAUPU AIBZZ VKYZS RNMKZ APXYR  
REVFN PIZYK LQHVQ OSALV TCJCL UBAAO NRAGB ZVUHJ NNMOH BXFAO CUPUM JWVUT MUBXG KRQYR KJXEB  
NTOUQ GPAJT LALPO ZTTIA HUMJT LVKJW WVJRC ZNLVL JNRJI JTTAK HDCIM QGJXA HPIYK CICES YRAPZ  
JMFEH RNMPA WWBGF FDXZV DSDYK NPCID MFCOF PYOKY VFOJX QKZHQ ZHSZT EQJVV AUPOO DHUMF AOLBX  
MFOKZ GOUVF HUBYR WNHLH UBYKK MUMJC XAAAO QSWQF HCIDS PZHSX XCJMG BYQOS MJBXD NTERE FZZVS

SEED: 4

POIGJQ5JR MOQ9 TEM M 4H7YIN OQ91H 5DMA JV AE 4M E CES3OL ZS1S4H4BTECIBAICUW Q8 5CICIBMU GL  
4T'OP4H6KZH5GL 2AAGGK R 6P2NS3SOU COL 4NS4H8 R UW 3 ZNS6P3UW NT IFBNMUXNS6L Q5JQ5COJR 2I  
NS7W 2AOK V OK XTAS AIBM 2ES2NNT MIGGJR 5FBMIJR 4BH H9 1T M XE Y POOR 3 L 5JW 1 2AET9 8 K  
P2NT UXT OFFNOL 3UPOUXET 4BM OET U FN 1 XMUYUWH 9OECOGPOIDS0EBNT H8 BM 2MIGKZS AUW P3S0AH7  
ZM TAUQ8 L 3S3 A ZT9 7WS6P1S3 ZT ECE XNT 3S3UR H 6L Y XAOFBNH 4MIK L 7ZT 6K BT S6Q7W 9 6P4  
H8 BH 4T9 5DMIFC ZMECIMIJXAAOKYOKZT 91TA 2IBTET 7W XAIN P1 ZNOL L OEC YUW 1H ECUWS3 1 1 OI  
GP4N 5FBAAIM AEH7XMUWS4H6R 6KYIBMOL GP1S7XAO L OVIDT UXNT OL 8 GKZNOQ5DS0OR OL 7VECET9 1S5  
D YOL MUZMIFNS6R EBNS4NUYUR M VQO6R 4H5DS2ES0IDT 2AUP4H4H6P1 Q6R S5JVIJXMIK Q8 FD VEN 5GK  
K W 1S3UQ6Q8 VET ENS3S 7XNH8 GJXE OIJWH9 5GP3OK JR IGK GP3 C ZH8 D CUVEMAUVAUR 2MIDH6L ZNU  
GJVQO8 BAOL 6Q8 CUQ7XNNNMUZH8 VOL 1 IBT NMOL 5C XT OQ6KY DMAS2INOVIK JWS3UVA 6Q7YOL 2IMAU  
Q6L 9 1 8 OAUP2AE XE 3 L 91 5JWUZM S6L 3 Q8 XM OECES IJW EBT OV OFNOQ7WUWH91T H TAH5C GL X  
T T H 4BAOJW 3UWUYINUXAQR AAD 6KYUR 7VOP4BT OJWS7WU FFD 4H5GJVEN57YUVAH6L 9 2NH 4T 7YOFQ  
XE XT E R S7ZH6R IDS IDT90OL H 6R OR 9 2AAE XNH 2E WH8 8 JQ9 6L 5FDT IDMECUP3 VIFCOJXEH6Q  
6R L CICUR 9 4T9 NNS3OJVAUP4T WH 5GP1 4BNS6Q5DT 4MAH8 P1T AUP2MOP1H 9 8 FBH 6K R 2AINOL AH  
5FFCUVPOUZN 90A COJVOVIGL OIFFN KZH7YUQ7VIFN 1T ET 9 6K VOVA 8 YOFFDMET NH 8 W 2ICOKZN YI  
BH9 7Y ZH6K KYUWU BH8 W JXM 2NTEN 1T 2ET IM IN Q90IJR H91 ZH5DT S5CUQ5FFNS30FCOGG6P1TEMAH6  
Q8 1TAH7VIJQ6Q6P2AUWS5GJXNH UZT 4H7WUY YIM H 3OFFBAUQ7ZT OGGP3S2M 4T 9 OK FBAINS3 XMOP3 3O  
KZS1T JQ7XMIDM OL 4N 2NS7Y 1H 7WS4MA 5FDS3 Y WUXMOR OP2M R AUWUWUYUQ5C Y 7XES2ET 2IC BNMIF  
DS1S5JXAICIDH5JQ7VA Y DS1 1S7VOL ZT 8 BAET IGP2EH8 JXAUV ICE 2AIBAUVEBTENU BMIFBTAS1 OASOA  
6R 2MUYOFNS4BAES3 FFBH OKY BTA ZT 4NU DS3OJQ6L H9 3OJXTET9 3 YIMIFFFBM OGR S3S2ICEH7VASO1  
GK Y ZM OJR OA YOK L 6Q6K GGPOAUR ET IK VECOK Q6K XEH4N 7YQJVEC DT 6P1T OL 2EH6L 1H9 3S NS  
3 ZH4H8 Q9 8 9OUXTEBAOFDT9 9 8 WH EH5JVAH4M S4T E MIKYIMA ZS3UWH9 EH7ZH4BNNMIJWUXAES1S7ZMA  
SOUYOL JR 8 W ZM NTET ET9 ID 7ZNUY MOL M P3OGL 8 Y 3 K R IFDT 8 R IDH8 GGGGK CE K YOJXNM 2  
M 1TAUVIDS2NT ET UY Y 5COFBT TA JW L 7V ESOAUW 5DH8 XAUQ5JWH 7Y XM W OU FCUQ9 AUR 3UQ8 K B  
NH8 YID R S3OL OUXNNTAS3UP4NS6K POEBT ES3S2AOGP2NNS5CINUZMA ZS2NS5JQ9 1 KYIDS3S0IK FDM NNM  
1 8 DH6R T INS5DM H8 KZMENUYICIMAH4BH8 DH5CET 6R 91S6Q9 6R S5FC P2E 8 Q5FNUXM 7XTA XNNS7V  
NT AAUQ91 OUY GJQ90UZS2E Y YUR AH7XAET 8 6L 4N WUZH4MIDM 8 V NNH A ZN AAUVOR 5GGJW L IBN  
H S7VET 3UVIGJV INOQ9 5CE ZT 2M OGK WS6R 7ZMIJQ8 ZH7W OIK XNMOVEMIDH4T 3 3UR 5D OAH4H4MA X  
TEMIKZT OR R TEBH 2NMOQ7XET T MUXE ZS0EMEBMOQ5GJQ7ZS30FN BH 2AUR U CET AS T IJR H AS1H91S4  
BH 2NH90Q6P0OP0IKY R 4M NS7WH OVEBNNH8 IMEBH90EN WS4BMOV E YOGL 8 L V ET91 JVEM 2NNNH 6P3  
7VOR T UZS0OP2AIDMEN E 6POEM ICOGKY YIBAAUPOA 1 2IDS1T IC YIDT UWS6KZM ES1TEBM YUQ9 3OGJR  
UYOJQ8 JVOL 7VENUWU C K GK P4T91H NM K K DH8 UXESOUW 7W IGGI 2IM OIFNOVAH8 L UZNUWH 2EH4T  
OQ7ZM OOP4M OFCE FDH5FN 91 1 L 2MIKZNS4MIGL 3OL 5CUV AOGK DMIJVIFFCID 2NM D 2MU BAAAIBT

SEED: 1005

XTERS ZH6RI SIDT9 OLH6R OR92A EXNH2 WH88J 96L5F TIDME UP3VI COJXE 6Q6RL CICUR 94T9N S30JV  
 UP4TW 5GP14 NS6Q5 T4MAH P1TAU 2M0P1 98FBH 6KR2A NOLAH FFCUV POUZN 9OACO VOVIG OIFFN KZH7Y  
 Q7VIF 1TET9 6KV0V 8Y0FF METNH 8W2IC KZNYI H97YZ 6KKYU UBH8W JXM2N EN1T2 TIMIN Q90IJ H91ZH  
 DTS5C Q5FFN 30FC0 GGP1T MAH6Q 1TAH7 IJQ6Q P2AUW 5GJXN UZT4H WUYUI H30FF AUQ7Z OGGP3 2M4T9  
 OKFBA NS3XM P33OK S1TJQ XMIDM OL4N2 S7Y1H 7WS4M 5FDS3 YWUXM ROP2M RAUWU UYU05 Y7XES ET2IC  
 BNMIF S1S5J AICID 5JQ7V YDS11 7VOLZ 8BAET IGP2E 8JXAU ICE2A BAUVE TENUB IFBTA 1OAS0 6R2MU  
 QFNS4 AES3F BHOKY BTAZT 4NUDS OJQ6L H930J TET93 YIMIF FBM00 S3S2I EH7VA OIGKY ZMOJR OAYOK  
 L6Q6K GGP0A RETIK VECOK Q6KXE 4N7Y0 VECDT 6P1T0 2EH6L 1H93S NS3ZH H8Q98 90UXT BAQFD 998WH  
 EH5JV H4MS4 EMIKY MAZS3 WH9EH ZH4BN MIJWU AES1S ZMAS0 YOLJR 8WZMN ETET9 ID7ZN YMOLM P30GL  
 8Y3KR IFDT8 RIDH8 GGGGK CEKY0 XNM2M 1TAUV DS2NT ETUYU SCOFB TAJWL 7VES0 UW5DH XAUQ5 WH7YX  
 WOUFC Q9AUR 3UQ8K BNH8Y DRS30 OUXNN AS3UP NS6KP EBTES S2A0G 2NNS5 INUZM ZS2NS JQ91K IDS3S  
 IKFDM NNM18 DH6RT INS5D H8KZM NUYYC MAH4B 8DH5C T6R91 6Q96R S5FCP E8Q5F UXM7X AXNNS VNTAA  
 UQ910 YGJQ9 UZS2E YYURA 7XAET 86L4N WUZH4 IDM8V NNHAZ AAUVO 5GGJW LIBNH S7VET 3UVIG VINQO  
 5CEZT 2M0GK WS6R7 MIJQ8 ZH7W0 KXNMO EMIDH T33UR 5D0AH H4MAX EMIKZ ORRTE H2NMO 7XETT MUXEZ  
 OEMEB Q05GJ 7ZS30 NBH2A RUCET ASTIJ HAS1H 1S4BH 2NH90 Q6P00 OIKYR 4MNS7 HOVEB NH8IM BH90E  
 WS4BM VEY0G 8LVET 1JVEM 2NNNH 6P37V RTUZZ OP2AI MENE6 OEMIC GKYYI AAUP0 12IDS TICYI TUWS6  
 ZMES1 EBMYU 930GJ UY0JQ JV0L7 ENUWU CKGKP T91HN KKD8H UXES0 W7WIG L2IMO FN0VA 8LUZN WH2EH  
 T0Q7Z 00P4M OFCEF H5FN9 1L2MI ZNS4M GL30L 5CUVA GKDMI VIFFC D2NMD 2MUBA AAIBT ECIDM ET5JR  
 6Q90A 2M0R9 4MEMI JXTNH 9OIFC H5COL ZS0P0 H5JXM DTAXE 8ZMET 5DH6P BNTAL OAVAF IBH8D MID7V  
 OGP4T 900VA WS7YI UP1H9 OVORA R7XTS N0ENO 7XEJQ FCIMM VOP2I NM6Q5 LFBMU 9S7XM 8CINI 4MT0U  
 H8BMU TYQ7Y KY5GG 6L7XN ECURI CXNS4 5GKZT 0ET7Z 9AQ6P MEBAE P4N0R EMEMA OUZTG KY0GJ S5DH4  
 UW2M6 DS80E S5GLA 3XAAE 5FCOL H87ZS VAS2A SS3JX ENR6L AIDH7 ZN2EF UZH6P IDT3S 2MUWV JVAXM  
 GPOUW WOET9 2IN35 91H8R 3ZT94 EN0P1 1H3XA ZN0VN 5FBH8 5JRA4 T00L9 2E800 8Q7WH R8P3Y P3UP2  
 MIDW7 H83S1 8GL1H P1S5F FDH7W 3SEMA KCOFD Q5CES 6R8YU IKZS3 94N0P URM1S LIKYU 1TAIM MHAUP  
 IGJQ5 RMOQ9 TEMM4 7YINO 91H5D AJVAE 4MECE 30LZS S4H4B ECIBA CUWQ8 5CICI MUGL4 OP4H6 ZH5GL  
 2AA0G KR6P2 S3S0U COL4N 4H8RU 3ZNS6 3UWNT IFBNM XNS6L Q5JQ5 OJR2I S7W2A KVOKX ASAIB 2ES2N  
 TMIGG R5FBM JR4BH H91TM XEYPO R3L5J 12AET 8KP2N UXT0F NOL3U OUXET 4BM0E UFN1X UYUWH 90ECO  
 POIDS EBNTM BM2MI KZSAU P3S0A 7ZMTA Q8L3S AZT97 S6P1S ZTECE XNT3S URH6L YXAF NH4MI L7ZT6  
 BTS6Q W96P4 8BH4T 5DMIF ZMECI IJXAA KYOKZ 91TA2 BTET7 XAINP ZNOLL OECYU 1HECU S3110 GP4NS  
 BAAIM AEH7X UWS4H R6KYI MOLGP S7XAO 0OVID UXNT0 8GKZM Q5DS0 ROL7V CET91 5DYOL MUZMI NS6RE  
 NS4NU URMVO 6R4H5 S2ESO DT2AU 4H4H6 1Q6RS JVIJX IKQ8F VEN5G KW1S3 Q6Q8V TENS3 7XNH8 GJXE0  
 JWH95 P3OKJ IGKGP CZH8D CUVEM UVAUR 2MIDH LZNUG VQ08B OL6Q8 CUQ7X NNMUZ 8VOL1 IBTNM L5CXT  
 UQ6KY DMAS2 NOVIK JWS3U A6Q7Y L2IMA Q6L91 80AUP AEXE3 L915J UZMS6 3Q8XM OECES IJWEB OV0FN

SEED: 7

4H6L I8 Q6L E6P2AAAES0/L 4H8 Y FBO IBAEH8 R A2IDH6Q91= ,N-X0.H4T9 3UWE4N= JQ6P1I8 X0,NE6Q  
 8' K FC Y L ZNE7X UA2U= JWA 8 KY JR 3S0, CUQ8 WA 6L 2E ZM U- FDT 3 DM IDH4BI .H6P3S30KYIC0FC  
 IN/R A 8 2ICIC0JV I 3 WE3S10.S2 I 5FFB 0 = Q91E5GP4H7V IBI 3UP3S = V/R 4M,UP1E4N/Q8 GK XAO  
 GJV?GP1I AZUA2IBU= 5CUP0/Q5FBO - BO ?KZH8 FCQJQ5DH5GGK JX U= 2AQJXU= 30L L 6K JQ8 R ?DT ,M  
 E7W= 4T I 2U/Q6Q5FD 8 0 ESGK V?K BAAUWI 4NE7V?D 30JR 7Y V AUQ6R ?JV,N/L 7YIB E7XE7YOGK L  
 OJQ9 5JX 0.H8 FN/R E4H7ZS0. KZNA I 4H4T 8 ZT . 90/P1E6P4T . YIDM?GK Q9 4H4N= L 1I ,M?FBA0  
 GL 3 X0 I90. 10 OK P1A0/Q9 91E3S OL 3 2E XAIM. YIC XU?FFB0,BO. 6KZT 5COKY 0/R ?FCUR E6R .U  
 WI I 7YIM,N/Q6L YIN/P4T 6Q6Q7X E3UR 2AQFFC FDS0?JV/P3S1= 10,COJWI E6P0?FBI 7W-XE V?GK RI9  
 0,UWA2EH7W= WI90-YID 6P2ET ,BI8 JV. XAUP1= YOGP3UV,N= JR -WA1= 3S2EH5DH7XE 5FNE3S3S1E6R AI  
 = P2U-XU?JX0 A AET -YUR 2 0 0 /R 6P4NA1A -Y YUP4H8 0?GL U?DT 7XU/L 2 E4B0 U= X 0 E4M IM.S  
 ET IN-Y ZN-ZN= Q5JXES1I .UV U-WA OFBI91A INA0?GGGJV.S -WI 6Q8 COK GJWI 2IM?K WA10,T E ZH5C  
 UW-X0 U/P4N-ZT 9 1A0,BI 5C ZNA1I9 8 Q6Q9 7ZNE5FDM?DT9 4M I9 6Q9 2U/V. P1I 4M A ?JQ7YIDH8 X  
 U/Q8 YOK W- BAUWA0/V/L 6K L KZS2IM I ?K K L 30FBU/R 4N/V,CUV?FBU= FFCET910,N= 0-WE30K BU/P  
 0/V AAET 3S2 U-YUPO,N-ZS1I8 5GL 3 0,BAIM?DM?K DT = P0.S1= CEH8 CE 7WI 8 L 1= W= 9 5FFDT ?G  
 L 5DT /L 9 UA 9 1I 2AE XE YINE4T -XAIBU?DS1A1= R I ICIN= 3 8 GGP4BU-ZNE3 R /L 2 E6R 30GP1A  
 2E 3 ZS E6K FNE5JWE6L 9 AOL 10 = 5FCUW18 ZS2AAIN-WE7V,UQ9 7ZM IBU-W-X I 7XAAUR 0.S0,NA0-XA  
 UR 6K Y 910 -W-ZT9 ,BAAE Y GL /Q5CIB0.UR ,COL 90,M.S10 0,N/V OL /R U?JQ5GKYUQ6K Q5D C CUR  
 A 7XU= L 6R .S2E P2INA2AAUP4BAIB E6KY ZS1A 6KZS0-XUA1A1E5FN/P2 U?GL Q8 V. 3S0/V,T ,C L 4BA  
 AOFNA0. B E4H5JR 3 8 BO ADFCUP4M?JWE4T 4B0.H6K R UA0?JXE BI 9 3UQ5GP0,T 6L 0/P3 ZT9 2AEH4M  
 ,T /V?JW= WE5JR = ZN/V/V,NA2IM,T90?DH5D 5CIM OGJXAEH6P2U?FCICES2UA0-ZM,M EH6R 6P0-WI . OFD  
 X E5DS U?FN- CIDT 5FCOFN-YOKYUUV OJXAKZH6Q7ZH7ZT91= 5JV,BAUP30FDH4M AAOL BO,M OKZM. 3UV E  
 H4BUA1I 8 L 8 4BU?KY 4M,C XAAAOJQ7W= P4H5CIDS0-ZH7X 0 ,M. BU= Q7ZM,BO I 91A10 E7ZN= Y X0 -  
 YIB0 A10 ?DS3UQ90,BU-YIM E 1E6K WI 5DS1I 6L 4H8 GP4M.S3S A 9 9 7V?KYOFBAE 9 9 /L DS2U-ZS3  
 P3 DT 8 JX0,C ZT .H4N/L 8 DS0.S30GGJXU/V?FDH6P0. ZH7V,BI U= /R . GKY Y 8 XET90,UV,T 8 JWI8  
 JR E4B I 9 ,T 4T 0 = XAE = XES 0 IDM 0 ,BU?GJR 5JQ6KZN-XEH5GK D V,M,T 2IBAOK KZT U/R I8 0  
 - DH7ZN/R 2ES ?FNA2U/L 0,M?JR /Q7V AINA 8 ZN= 4NA 0 OGL ,CET = P4BI 7V?GGKZH4NE3UP10 E7YOK  
 DH4H5FB E5GGP2ICUV. ZM.H5GP2UA 6R 0,CEH4H7X0 AE GGJQ6R 8 ES1= K CUP2E L 0. YUV,CIC ZS30L  
 ES2ID 1= 6P1A 91= R 8 Q8 P2AIM E5DT9 AZAUV?JR 90?KZM?GGP0- GK FFFNA 6Q7V,M UA 7V.H5DM,M,N=  
 ZS0?FD 91I 3UR /V.S3 XE Q9 - GGL ZM.UR 8 FFN-W= 2 U/R I8 COGL PO-Y 4N-X U- CUWA 2IDM. 5JQ  
 8 B 0 /P1= 0. XUA .S0/Q7X0 ?GJW-Y XES3 4T 4N= 2ET 7ZS3S3 ZM?KY X0. W= R = KYOL 5GJWA0?D K  
 JV?DM.H7Y YOJWA2 UAO.H4BAUR OL R 5FN= V ID ZH8 K XU= L ZH6L 6P30L 5GL 7WA1E7WE7X0,T = 3 GP  
 0/L W-YOGGL 8 C YOL 7YUR /P30JW- DM,B I9 I - D 6R U-Y Q5GGGL 1E4T90-W= K V.H7WE5FCE YUQ8 D  
 T91E7Y CIB 0,M,COFFNE7ZT 6R 5CEH6K CIM,CE V/P10. DH6KY0JR ,NA 4B U= V,BUA U-W18 0-YUV/V IM

SEED: 1008

4H8Q9 890-X ,BAOF T998W EH5JV H4ME4 EU?KY M.ZS3 WI9EH ZH4BU JW-XA S1E7Z .S0-Y LJR8W ZMO,T  
 ,T9?D 7ZN-Y U/LU= P30GL 8Y3KR ?FDT8 R?DH8 GGGGK CEKY0 XU=2U 10.UV DS20E -YY5C FB00. JW=L7  
 ES0.U =5DH8 XAUQ5 WI7YX =WA0- FCUQ9 .UR3U 8KBI8 YIDRE 0L0-X 0.S3U 4NE6K P0,B0 ES3S2 0GP2E  
 CIN-Z .ZS2E JQ91= KYIDS S0?KF MUA1= 8DH6R 0INE5 MI8KZ ,N-YI IM.H4 I8DH5 ET6R9 E6Q96 =AE5F  
 P2E8Q FN-XU 7X0.X E7V0A AUQ91 0-YGJ 90-ZS EYYUR .H7XA T86L4 =W-ZH M?DMA 8VI.Z =AAUV R5GGJ  
 =LIBI E7V,T 3UV?G VIN/Q 5CEZT 2UA0G WE6R7 M?JQ8 ZH7WA ?KXU/ ,M?DH T33UR 5D0.H H4M.X ,M?KZ  
 /R=RO BI2U/ 7XET0 U-XEZ 0,M,B /Q5GJ 7ZS30 N=BI= 2AUR- CET.S 0?JRI .S1I9 E4BI2 I90/Q PO/PO  
 KYR4M E7WI/ ,BI8I ,BI90 N=WE4 U/VEY GL8LV ET91= JV,MA I6P37 /R0-Z 0/P2A IM,NA E6P0, ICOGK  
 YIBAA P0.1= 2IDS1 ICYID -WE6K MES10 BU=YU 930GJ -Y0JQ JV/L7 ,N-W- CKGKP T91IU KKD8H -XES0  
 WA7W= ?GGL2 MA0?F /V.H8 L-ZN- I2EH4 /Q7ZN 0/P4M 0FCEF H5FNA 91=1= L2U?K NE4M? L30L5 UVA0G  
 DM?JV FFCID 2U=D2 -BAAA IB0,C DMET5 R6Q90 S2U/R 9=4M, ?GJX0 I990? CEH5C LZS/P .H5JX -DT.X  
 H8ZM, 5DH6P B0.L0 V.FCI I8DMU D7V0G 4T90/ .UWE7 ICUP1 9/V/R AUR7X E4NA0 N/R7X JQ5FC MU/V/  
 2IBUA 6Q5GL FBU-Y 9E7XU 8CINA E4M0A -W18B -X0=Y Q7YKY 5GGL6 7X0,C R?KCX E4T5G ZT90, 7ZS9.  
 Q6P4M BAEP4 /R,M, .0-ZT =GGKY GJWE5 H4N-W 2UA6K DS80, E5GL. 3XAAE 5FCOL I87ZS =V.S2 ESE3J  
 0,N=R 6LAID 7YZNA EFN-Z 6P2ID 3S1A2 -W=V? V.XU? P0-W- A0,T9 A2IN= 35D91 8R3ZT =94T, /P1A1  
 3XAEZ /VE5F I85JR .4B0= 0/L92 80/Q8 Q7WI8 R8P3Y P3UP2 M?DWA 7ZH83 1I8GL A1I8P E5FFF H7WI3  
 ,MAOK COFDS =Q5CE 1A6R8 YUV?K S394N P3URU 1E6L? YUP1A OAIM, I.UPO GJQ5J U/Q90 MU=4H YINA/  
 91I5D .JVAE 4MECE 30LZS E4H4B ,CIBA CUW=Q 5CICI U-GL4 /P4H6 ZH5GL 2AA0G KRA6P E3S0- COL4N  
 4H8R- =3ZNE P3UWA 0?FBU XE6LQ JQ5C0 R2INE WA2A0 VOKX0 SAIBU 2ES20 U?GGJ 5FBU? R4BII 10UA=  
 XEYF0 R3L5J A1A2A T98KP 0-X00 FN/L3 P0-XE 4BU=0 T-FNA =XU-Y WI90, 0GP0? S0,B0 I8BUA 2U?GK  
 SAUW= P3S0. 7ZM0. Q8L3S .ZT97 E6P1E ZT,CE X0A3S URI6L YXAOE I4M?K L7ZT6 B0E6Q WA96P H8BI4  
 95DM? CZM,C M?JXA OKYOK T910. 2IB0, 7W=XA N=P1= ZN/LL 0,CYU A1I,C WE31A A0?GP N=5FB AIMAE  
 7XU-W 4H6R6 YIBU/ GP1E7 AOL0/ ?DT-X 00L8G ZN/Q5 S0/R/ 7V,CE 91E5D YOLU- M?FNE R,BE4 -YURU  
 V/Q6R 4H5DS ES0?D 2AUP4 4H6P1 Q6RE5 V?JXU KQ8FD V,N=5 KKW=1 3UQ6Q V,T,N 3S7XI GJXE0 JWI95  
 P3QKJ ?GKGP CZH8D CUV,M UV.UR A2U?D 6LZN- GJV/Q BAOL6 8CUQ7 U-ZH8 V/L1A IB0U/ 5CX0/ 6KYDM  
 S2IN/ ?KJWE UV.6Q YOL2I .UQ6L 9A1A8 0.UP2 EXE3L 91A5J -ZME6 3Q8XU 0,CES ?JWA, 0/V0F /Q7W-  
 I910I 0.H5C GLX00 I4BA0 W=3UW YIN-X 0JRAA D6KYU 7V/P4 00JWE W-FFD 4H5GJ ,NE7Y V.H6L 92I4T  
 7Y0FC XEX0E RE7ZH RIDSI T90/L I6R/R 92AAE XI2EW 88JQ9 6L5FD ?DM,C P3V?F 0JXEH Q6R=L CICUR  
 94T9E 0JV.U 4T=WI 5GP1= 4BE6Q DT4M. 8P10A P2U/P I98FB 6KR2A N/L.H FFCUV P0-ZN 90.CO V/V?G  
 0?FFN KZH7Y Q7V?F =10,T 96KV/ .8Y0F DM,TI 8WA2I 0KZN= YIBI9 7YZH6 KYUW- BI8W= JXUA2 0,NA1  
 A2ETI IN=Q9 ?JRI9 =ZH5D E5CUQ FFNE3 FCOGG P10,M H6Q81 .H7V? Q6Q6P AUWE5 JXIA- T4H7W YYIMI  
 30FFB UQ7ZT 0GGP3 2U=4T 90KFB INE3X /P330 ZS10= JQ7XU DMOL4 A2E7Y 1I7WE M.5FD 3YW-X /R/P2  
 =R.UW W-YUQ CY7XE 2ET2I BU?FD 1E5JX ICIDH JQ7V. YDS1= 1E7V/ ZT8BA T?GP2 H8JXA VICE2 IBAUV

SEED: 10

GJW= L IB! / ;7V,T 3UV?GJV IN/Q9 5CE ZT 2( : 0GK W;6R 7ZM?JQ8 ZH7W:0?K X!( /V,M?DH4T 3 3UR 5D  
 0.H4H4M. X",M?KZT /R = R ",B' 2!( /Q7XET " (-XE ZS0,M,B(/Q5GJQ7ZS30FN= B' = 2AUR - CET .S  
 " ?JR / .S1'91;4B' 2!'90/Q6P0/PO?KY R 4M !;7W' /V,B!'!8 IM,B'90,N= W;4B(/V E Y0GL 8 L V ET  
 91= JV,M :2!'!' 6P3 7V/R " -ZS0/P2AIDM,N: E 6P0,M ICOGKY YIBAAUPO. 1= 2IDS1" IC YIDT -W;6K  
 ZM ES1",B(= YUQ9 30GJR -Y0JQ8 JV/L 7V,N-W- C K GK P4T91' !(= K K DH8 -XES0-W: 7W= ?GGL 2IM  
 :0?FN/V.H8 L -ZN-W' 2EH4T /Q7ZN:0/P4M 0FCE FDH5FN: 91= 1= L 2(?KZN;4M?GL 30L 5CUV A0GK DM  
 ?JV?FFCID 2!(= D 2(- BAAAAIB" ,CIDM ET 5JR 6Q90.S2(/R 9 = 4M,M?GJX" !'9 90?FCEH5COL ZS /P0  
 .H5JX(- DT . XEH8 ZM,T 5DH6P4B!". L 0. V. FCIB' 8 DM (?D 7V 0GP4T 90/V.UW;7YICUP1'9 /V/R A  
 UR 7X" ;4N:0,N/R 7XE JQ5FCIM (/V/P2IB!( : 6Q5GL FB(-Y 9 ;7X( : 8 CIN:1;4M " :0-W'8 B(-X" = Y  
 Q7Y KY 5GGL 6L 7X!",CUR ?K C X!;4T 5GKZT90,T 7ZS 9 . Q6P4M,BAE P4N/R ,M,M. 0-ZT = GGKY0GJ  
 W;5DH4N-W:2( : 6K DS 8 0,N;5GL .S3 XAAEH5FCOL / 8 7ZS1= V.S2AES ;3 JX" ,N= R 6L AIDH7Y ZN:2  
 E FN-ZH6P2IDT 3S1:2(-W= V?JV. X(?GP0-W-W:0,T91:2IN= 3 5D 91'8 R 3 ZT = 9 4T ,N/P1:1' 3 XAE  
 ZN/V !;5FB'8 5JR . 4B" = 0/L 9 2E 8 0/Q8 Q7W'8 R 8 P3 YUP3UP2IM?D W: 7ZH8 3S1' 8 GL :1'8  
 P1;5FFFDH7W' 3S ,M AOK COFDS = Q5CES1: 6R 8 YUV?KZS3 9 4N/P3UR (:1;6L ?KYUP1: " AIM,M / .U  
 P0?GJQ5JR (/Q9 ,M (= 4H7YIN: /Q91' 5DM. JV AE 4M E CES30L ZS1;4H4B",CIBAICUW= Q8 5CICIB(-  
 GL 4T /P4H6KZH5GL 2AA0GGK R : 6P2!;3S0- COL 4N;4H8 R -W= 3 ZN;6P3UW: !" ?FB!(-X!;6L Q5JQ5  
 COJR 2IN;7W:2AOK V OK X".S AIB(:2ES2!" (?GGJR 5FB(?JR 4B' '9 1" (: = XE Y PO/R 3 L 5JW:1:  
 2AET9 8 K P2!" -X" OFFN/L 3UP0-XET 4B(= 0,T - FN:1= X(-YUW' 90,COGPO?DS0,B!" '8 B(: 2(?GKZ  
 S AUW= P3S0.H7ZM ".UQ8 L 3S3 . ZT9 7W;6P1;3 ZT ,CE X!" : 3S3UR / 6L Y XAOFB!' 4M?K L 7ZT 6  
 K B" ;6Q7W: 9 6P4H8 B' 4T9 5DM?FC ZM,CIM?JXAAOKYOKZT 91". 2IB",T 7W= XAIN= P1= ZN/L L 0,C  
 YUW:1' ,CUW;3 1:1:0?GP4N= 5FBAAIM AEH7X(-W;4H6R 6KYIB(/L GP1;7XAOL 0/V?DT -X!" 0L 8 GKZN/Q  
 5DS0/R /L 7V,CET9 1;5D YOL (-ZM?FN;6R ,B!;4N-YUR (= V/Q6R 4H5DS2ES0?DT 2AUP4H4H6P1= Q6R ;5  
 JV?JX(?K Q8 FD V,N= 5GK K W= 1;3UQ6Q8 V,T ,N;3S 7X!'8 GJXE 0?JW'9 5GP30K JR ?GK GP3 C ZH8  
 D CUV,M.UV.UR :2(?DH6L ZN- GJV/Q8 BAOL 6Q8 CUQ7X!!!(-ZH8 V/L 1: IB" !(/L 5C X" /Q6KY DM.S2  
 IN/V?K JW;3UV. 6Q7YOL 2IM,UQ6L 9 :1: 8 0.UP2AE XE 3 L 91: 5JW-ZM ;6L 3 Q8 X(:0,CES ?JW: ,B  
 " /V 0FN/Q7W-W'91" / ".H5C GL X" " / 4BA0JW= 3UW-YIN-XA0JR AAID 6KYUR 7V/P4B" 0JW;7W- FFD  
 4H5GJV,N;7YUV.H6L 9 2!' 4T 7Y0FC XE X" E R ;7ZH6R IDS IDT90/L / 6R /R 9 2AAE X!' 2E W'8 8  
 JQ9 6L 5FDT ?DM,CUP3 V?FCOJXEH6Q6R = L CICUR 9 4T9 !!;30JV.UP4T = W' 5GP1= 4B!;6Q5DT 4M.H8  
 P1" AUP2(/P1' 9 8 FB' 6K R 2AIN/L .H5FFCUV/PO-ZN: 90. COJV/V?GL 0?FFN= KZH7YUQ7V?FN= 1" ,  
 T 9 6K V/V. 8 YOFFDM,T !' 8 W:2ICOKZN= YIB'9 7Y ZH6K KYUW- B'8 W= JX(:2!" ,N:1" :2ET IM IN=  
 Q90?JR '91= ZH5DT ;5CUQ5FFN;30FCOGGP1",M.H6Q8 1".H7V?JQ6Q6P2AUW;5GJX!' : -ZT 4H7W-Y YIM  
 / 30FFBAUQ7ZT 0GGP3S2(= 4T 9 OK FBAIN;3 X(/P3 30KZS1" = JQ7X(?DM 0L 4N:2!;7Y 1' 7W;4M. 5FD  
 S3 Y W-X(/R /P2(= R .UW-W-YUQ5C Y 7XES2ET 2IC B!(?FDS1;5JXAICIDH5JQ7V. Y DS1= 1;7V/L ZT 8



SEED: 1000

AAAIB ,CIDM ET5JR 6Q90. 2(/R9 =4M,M GJX"! 990?F EH5CO ZS/P0 H5JX( DT.XE 8ZM,T 5DH6P B!".L  
O.V.F IB'8D (?D7V OGP4T 90/V. W;7YI UP1'9 /V/RA R7X"; N:0,N R7XEJ 5FCIM (/V/P IB!( : 6Q5GL  
FB(-Y 9;7X( 8CIN: ;4M": -W'8B -X"=Y Q7YKY 5GGL6 7X!", UR?KC X!;4T 5GKZT 0,T7Z 9.Q6P M,BAE  
P4N/R ,M.M. 0-ZT= GGKY0 JW;5D 4N-W: (:6KD 80,N; GL.S3 XAAEH FCOL' 87ZS1 V.S2A S;3JX ,N=R6  
AIDH7 ZN:2E FN-ZH P2IDT 3S1:2 -W=V? V.X(?) PO-W- :0,T9 :2IN= 35D91 8R3ZT =94T, /P1:1 3XAEZ  
/V!;5 B'85J .4B"= 0/L92 80/Q8 Q7W'8 R8P3Y P3UP2 M?DW: 7ZH83 1'8GL :1'8P :5FFF H7W'3 ,MAOK  
COFDS =Q5CE 1:6R8 YUV?K S394N P3UR( 1:6L? YUP1: "AIM, ^,UP0 GJQ5J (/Q9" M(=4H YIN:/ 91'5D  
.JVAE 4MECE 30LZS ;4H4B ,CIBA CUW=Q 5CICI (-GL4 /P4H6 ZH5GL 2AA0G KR:6P !;3S0 COL4N 4H8R-  
=3ZN; P3UW: !"?FB (-X!; LQ5JQ COJR2 N;7W: AOKV0 X".SA B(:2E 2!!"( GGJR5 B(?JR 4B'9 1"( :=  
XEYPO R3L5J :1:2A T98KP !"-X" OFFN/ 3UPO- ET4B( 0,T-F :1=X( YUW'9 ,COGP ?DS0, !"8B :2(?G  
ZSAUW P3S0. 7ZM". Q8L3S .ZT97 ;6P1; ZT,CE X!":3 3UR'6 YXAOE !'4M? L7ZT6 B";6Q W:96P H8B'4  
95DM? CZM,C M?JXA OKYOK T91". 2IB", 7W=XA N=P1= ZN/LL 0,CYU :1',C W;31: :0?GP N=5FB AIMAE  
7X(-W 4H6R6 YIB(/ GP1;7 A0L0/ ?DT-X "OL8G ZN/Q5 S0/R/ 7V,CE 91;5D YOL(- M?FN; R,B!; N-YUR  
(=V/Q R4H5D 2ES0? T2AUP H4H6P =Q6R; JV?JX ?KQ8F V,N=5 KKW=1 3UQ6Q V,T,N 3S7X! 8GJXE 0?JW'  
5GP30 JR?GK GP3CZ 8DCUV M.UV. R:2(?) H6LZN GJV/Q BAOL6 8CUQ7 !!!(- H8V/L 1:IB" !(/L5 X"/Q6  
YDM.S IN/V? JW;3U .6Q7Y L2IM. Q6L9: :80.U 2AEXE 3L91: 5JW-Z ;6L3Q X(:0, ES?JW ,B"/V QFN/Q  
W-W'9 "'".H CGLX" "'4BA JW=3U -YIN- A0JRA ID6KY R7V/P B"0JW 7W-FF 4H5GJ ,N;7Y V.H6L 92!'4  
7Y0FC XEX"E R;7ZH RIDSI T90/L '6R/R 92AAE X!'2E W'88J 96L5F T?DM, UP3V? COJXE 6Q6R= LCICU  
94T9! ;30JV UP4T= W'5GP =4B!; Q5DT4 .H8P1 AUP2( P1'98 FB'6K R2AIN L.H5F CUV/P -ZN:9 .COJV  
V?GLO FFN=K H7YUQ V?FN= 1",T9 6KV/V 8YOFF M,T!' 8W:2I OKZN= YIB'9 7YZH6 KYUW- B'8W= JX(:2  
",N:1 :2ETI IN=Q9 ?JR'9 =ZH5D ;5CUQ FFN;3 FCOGG P1",M H6Q81 .H7V? Q6Q6P AUW;5 JX!': -ZT4H  
W-YI 30FF AUQ7Z OGGP3 2(=4T 90KFB IN;3X /P330 ZS1"= JQ7X( DM0L4 :2!;7 1'7W; M.5FD 3YW-X  
/R/P2 =R.UW W-YUQ CY7XE 2ET2I B!(?F S1;5J AICID 5JQ7V YDS1= 1;7V/ ZT8BA T?GP2 H8JXA VICE2  
IBAUV B",N- B(?FB .S1:0 S0.6R 2(-Y0 N;4BA S3FFB OKYB" ZT4N- DS30J 6L'93 JX",T 3YIM? FFB(:  
/R;3S ICEH7 .S0?G YZMOJ :0.Y0 L6Q6K GGP0. R,T?K V,COK Q6KXE 4N:7Y JV,CD 6P1"/ 2EH6L 1'93S  
!;3ZH H8Q98 90-X" BAOFD 998W' EH5JV H4M;4 E(?KY M.ZS3 W'9EH ZH4B! (?JW- AES1; ZM.S0 YOLJR  
8W=ZM !",T, 9?D7Z -Y(/L (=P30 L8Y3K R?FDT 8R?DH GGGGK CEKY0 X!(=2 :1".U ?DS2! ET-YY 5COFB  
",JW= L7VES .UW=5 H8XAU 5JW'7 X(=W: -FCUQ .UR3U 8KB!' YIDR; 0L0-X !".S3 P4N;6 P0,B" ES3S2  
OGP2! ;5CIN ZM.ZS !;5JQ 1=KYI S3S0? FDM!! :1=8D 6R"IN 5DM'8 KZM,N YICIM H4B'8 DH5CE 6R91;  
Q96R= ;;5FC P2E8Q FN-X( 7X".X !;7V! AAAUQ 1:0-Y GJQ90 ZS2EY YUR.H XAET8 6L4N= W-ZH4 ?DM:8  
V! !'. ZN=AA V/R5G JW=LI !';7V T3UV? JVIN/ 95CEZ 2(:0G W;6R7 M?JQ8 ZH7W: ?KX!( V,M?D 4T33U  
5D0.H H4M.X ,M?KZ /R=R" B'2!( Q7XET "(-XE ZS0,M B(/Q5 JQ7ZS OFN=B =2AUR -CET. "?JR' .S1'9  
;4B'2 '90/Q P0/P0 KYR4M !;7W' /V,B! '8IM, '90,N W;4B( VEY0G 8LVET 1=JV, :2!!! 6P37V R"-ZS

## Summary of Commands

The following commands are recognized by your CW Keyboard. This summary is also printed on the bottom of the chassis.

TONE	Sidetone on/off.
CLICK	Key depression click on/off.
TUNE	Key/unkey output.
HOLD	Hold/release type-ahead buffer.
DELETE	Delete last-typed key.
DELETE WORD	Delete last-typed word.
STOP	Terminate operation.
WPM	Display speed setting*.
SPC'G	Display spacing setting*.
WT	Display weight setting*.
S/N	Send serial number.
PREV	Send previous serial number.
SET n WPM	Set speed and spacing to n.
SET n SPC'G	Set spacing to n.
SET SPC'G	Set spacing equal to speed.
SET n WT	Set weighting to n.
SET WT	Set normal weighting.
SET n S/N	Set serial number to n*.
SET PREV	Decrement serial number.
SET n LOAD	Prepare to load buffer n.
SET n PROT	Protect/unprotect buffer n.

### SET n PRAC

Select code practice where n is a "seed" for a pseudo-random character generator. The right-most digit of n determines the types of characters generated:

1 — 3:	Letters only.
4 — 6:	Letters and numbers.
7 — 9:	Letters, numbers, and common punctuation.
0:	Letters, numbers, and all punctuation.

n = 0 — 999:	Random-length groups.
n = 1000 — 1999:	5-character groups.
n = 2000 — 2999:	Copy mode.

In the copy mode, SPACE repeats a character; DELETE skips the character.

\* The display defaults to the serial number if it is in use (non-zero). Otherwise, it defaults to the speed (WPM).

## IN CASE OF DIFFICULTY

This part of the Manual helps you locate and correct any difficulty which might occur in your CW Keyboard. This information is divided into three sections. The first section, "General," contains suggestions in the following areas:

- A. Visual checks and inspection.
- B. Precautions to observe when you test the CW Keyboard.
- C. How to troubleshoot your CW Keyboard.

- D. How to repair the CW Keyboard.

The second section consists of a "Troubleshooting Chart." This chart calls out specific problems that may occur and lists one or more conditions that could cause each difficulty. The resistor R numbers, capacitor C numbers, transistors Q numbers, and diode D numbers are identified in this chart by the same numbers used on the Schematic Diagram. X-Ray Views are also provided to help you locate the component and test points.

## GENERAL

### VISUAL TESTS

1. About 90 percent of the kits returned for repair do not function properly due to poor connections and soldering. Therefore, you can eliminate many difficulties by a careful inspection of the connections to make sure they are soldered as described on Page 11. Reheat any doubtful connections and make sure all of the wires are soldered at places where several wires are connected.
2. Check the circuit board to be sure there are no solder bridges between adjacent connections. You can remove any solder bridges by holding a clean soldering iron tip between the two points that are bridged. The excess solder will flow down the tip of the soldering iron.
3. Be sure each transistor and integrated circuit is in the proper location (correct part number and type number). Be sure each transistor lead is positioned properly and has a good solder connection to the foil. Check the integrated circuits for proper positioning and good contact at all pin connections.
4. Check capacitor values carefully. Be sure the proper part is wired into the circuit at each capacitor location. Also be sure each electrolytic capacitor is installed with the proper polarity.
5. Check each resistor carefully. A resistor that is discolored, cracked, or shows any sign of bulging indicates that it is faulty and should be replaced.

6. Be sure the correct diode is installed at each diode location, and that the banded end is positioned correctly.
7. Recheck the wiring. It is frequently helpful to have a friend check your work. Someone who is not familiar with the unit may notice something that you have consistently overlooked.
8. Check all component leads connected to the circuit board. Make sure the leads do not extend through the circuit board and make contact with other connections, parts, or the metal chassis.
9. Check for bits of solder, wire ends, or other foreign matter which may be lodged in the wiring.

NOTE: In an extreme case where you are unable to resolve a difficulty, refer to the "Customer Service" information inside the rear cover of the Manual. Your Warranty is located inside the front cover.

### PRECAUTIONS FOR BENCH TESTING

1. Be cautious when you test solid-state circuits. Although transistors and integrated circuits have almost unlimited life when used properly, they are much more vulnerable to damage from excessive voltage or current than other circuit components.
2. Be sure you do not short any terminals to ground when you make voltage measurements. If the probe slips, for example, and shorts out a bias or voltage supply, this could cause damage to one or more transistors or diodes.

3. Do not remove transistors or integrated circuits while the CW Keyboard is turned on, as this could damage the unit.

### HOW TO TROUBLESHOOT YOUR CW KEYBOARD

If you know which area your particular problem is in, apply the "Visual Checks" to that area.

You may also proceed directly to the "Troubleshooting Chart" to see if the difficulty you are having is listed in one of the "Problem" columns. If your difficulty is listed there, check the "Possible Causes" listed for that problem and apply the "Visual Checks" listed to the area of difficulty.

### REPAIRING THE CW KEYBOARD

When you make repairs to your CW Keyboard, make sure you eliminate the cause as well as the effect of the difficulty. If, for example, you find a damaged resistor, be sure you find out what it was (wiring error, etc.) that caused the resistor to become damaged. If the cause is not eliminated, the replacement resistor may also become damaged when you put the CW Keyboard back into operation.

## TROUBLESHOOTING CHART

This Troubleshooting Chart lists specific difficulties that could occur in your CW Keyboard. Several possible causes may be listed for each difficulty. Refer to the Circuit Board X-Ray Views and the Schematic Diagram to locate and identify the parts listed in this chart.

If a particular part is mentioned (U1 for example) as a possible cause, check that part and other compo-

nents connected to that part to make sure they are installed and/or wired correctly. Also check for solder bridges and poor connections in the surrounding area. It is also possible for a part to be faulty and require replacement.

NOTE: Check each resistor in the problem area and make sure it is not interchanged with a resistor that has a similar color code.

PROBLEM	POSSIBLE CAUSE
Display indicates "U1".	1. Integrated circuit U1.
Display indicates "U2", "U3", "U4", or "U5" after it is reset.	1. If "U5" is displayed, check the backup switching circuitry (Q17 and Q18).
	NOTE: The RAM test checks U3, U5, U2, and U4 (in that order) and stops checking when it finds a fault. Therefore, if there is more than one fault, only the first one encountered is displayed. You can interchange the suspected IC with one at a later-checked position, and perform a reset again to assure that there are no other faults.
No sidetone.	1. Integrated circuit U9. 2. Speaker SP101. 3. Turned off. Press SHIFT and TONE keys. 4. Check connections at plugs P1 and P2.
" - " keyjack is inoperative, sidetone is okay.	1. Check for -3 volts DC at the anode of diode D13. If it is not present, check capacitors C3 and C4, diodes D13 and D14, and transistors Q14 and Q15. If it is present, check transistors Q12 and Q13.
None of the seven-segment displays light.	1. Integrated circuits U6 and U7.
A particular segment does not light in any of the four seven-segment displays.	1. Associated segment driver (Q1 through Q8).
No segments light in one of the seven-segment displays.	1. Associated digit driver (Q201 through Q204).
No segments light on the LED bar.	1. Integrated circuits U6 and U8. 2. LED bar improperly installed.
Some keys are inoperative.	1. Check diodes D2 through D9. If one of these is installed backwards, the keys in the associated column of the keyboard matrix will not operate. 2. Check connections at plugs P1 and P2.
Contents of the buffers are lost when power is disconnected.	1. Batteries B1, B2, and B3. 2. Diode D23.



## SPECIFICATIONS

Speed Range .....	1 to 99 WPM.
Spacing .....	Less than or equal to the speed.
Weighting .....	Normal plus five "light" and five "heavy" settings.
Serial Number .....	1 to 9999.
Code Practice .....	Four levels; 1000 different random groups of approximately 3000 characters each, in five-character or random-length groups. Special "copy" mode improves typewriter copy proficiency.
Text Buffers .....	1 to 10; variable length, with a total capacity of 495 characters. The contents of individual buffers may be protected. 64-character type-ahead buffer.
Keyer Output .....	+ 250 volts @ 100 mA.; - 200 volts @ 40 mA.
Memory Backup .....	3 miniature cells with a lifetime of 1 year (typical).
Sidetone .....	Adjustable pitch (300 - 1500 Hz) and volume.
Character Set .....	A - Z, 0 - 9, CQ, DE, ES, BK, AR, AS, BT (-- or =), KN, SK, punctuation: . , ? / - : ; " ' ( and !.
Indicators .....	4-digit LED display, SET, MSG, LOAD, PRAC, and type-ahead buffer status LED's.

Microprocessor .....	Custom 3870.
Operating Temperature Range .....	32 – 104° F. (0 – 40° C.)
Power Requirements .....	7.5 to 11 VAC or 11 to 16 VDC, 450 mA maximum. Optional power cube available.
Dimensions (overall) .....	15-1/2" wide × 8" deep × 2-7/8" high (39.4 × 20 × 7.3 cm).
Weight .....	7 lb. (3.2 kg).

---

The Heath Company reserves the right to discontinue products and to change specifications at any time without incurring any obligation to incorporate new features in products previously sold.



## CIRCUIT DESCRIPTION

Refer to the Schematic Diagram (fold-in) as you read the following description. Each major section of the CW Keyboard is described below separately.

The component numbers are arranged in the following groups to help you locate specific parts on the Schematic, circuit boards, and chassis:

- 1-99 Parts mounted on the main circuit board.
- 101-199 Parts mounted on the chassis.
- 201-299 Parts mounted on the display circuit board.

### CONTROLLER

The heart of the Model HD-8999 CW Keyboard is formed by integrated circuit U1, a custom 3870, single-chip microprocessor. This integrated circuit scans and debounces the keyboard, determines character timing, stores data to and retrieves data from the external RAM (random-access memory), and supplies information to the display.

The 3579.545 kHz crystal (Y1) determines the frequency of the internal clock circuitry. This frequency is divided inside the microprocessor to provide a 500 microsecond basic timing interval. The dots, dashes, and interelement, intercharacter, and interword spaces are multiples of this interval which depend upon the speed, spacing, and weight settings.

Capacitor C1 and a pull-up resistor inside the microprocessor provide a power-on reset to the microprocessor. Diode D1 allows capacitor C1 to discharge quickly when you turn the Keyboard off and insures that a reset occurs if the power is only briefly interrupted.

Port 0 of the microprocessor forms an address bus for the external RAM, which consists of integrated circuits U2, U3, U4, and U5. This RAM is used as a message buffer memory and also saves the Keyboard settings when you turn the Keyboard off.

Port 4 provides a data bus for the external RAM. It also supplies segment patterns to "buffer fullness" LED bar V205 and to four-digit, seven-segment displays V201 through V204. When data is output to port 4, strobe pin 7 briefly pulses low to stobe the data to the correct device. Signals from port 5 determine whether the RAM, LED bar, or seven-segment display receives this data.

Port 5 is a multi-purpose port. Bits 0, 1, and 2 scan the keyboard through 3-line to 8-line decoder U7. The data on these bits sequence through binary values 0 to 7, which causes outputs 0 through 7 of U7 to go low one at a time. If you press any key in the column that is connected to that output, it is read into port 0 and the appropriate action occurs.

Bit 7 of port 5 keys the output circuitry, while bit 6 keys the sidetone, as required.

Bits 3, 4, and 5 are the control lines that determine which device receives the data that is on the data bus. Normally, all three of these lines are high, which causes the output of NAND gate U6A to be low. This low enables U7 and allows the seven-segment displays to be enabled by transistors Q201, Q202, Q203, and Q204. To update the LED bar, bit 3 of port 5 is taken low. This causes the output of NAND gate U6C to go low, which enables latch U8. The data is then placed onto the data bus and the strobe pulse from the microprocessor clocks the data into the latch.

Bits 4 and 5 of port 5 provide RAM page select. Bit 3 disables the output of the RAM's. When the microprocessor reads data from RAM, the desired address is first output to the address bus (port 0). Then the address page select line is taken low, the output disable (OD) pins are taken low (enabled), and the data is read into port 4.

To write to RAM, the appropriate page is selected (as in the read operation) and bit 3 remains high to disable the RAM output stages. The data is then output to the data bus and is accompanied by the low-going strobe pulse, which writes the data into the selected address.

Whenever the LED bar is updated or RAM is being read or written to, at least one of the inputs to NAND gate U6A is low, which disables U7. This causes all of the outputs of U7 to be high and keeps the data from being applied to the seven-segment displays.

Diodes D2 through D9 avoid erroneous entries that are caused when you press two keys simultaneously.

## **SIDETONE OSCILLATOR/CHARGE PUMP**

NOR gates U9A, U9B, and U9C form an astable oscillator which runs continuously. The microprocessor gates the output of this oscillator through NOR gate U9D before it is applied to speaker driver transistor Q16. Control R21 allows you to adjust the sidetone pitch.

The output of the sidetone oscillator also drives a charge pump through transistors Q14 and Q15. This charge pump (which consists of capacitors C3 and C4 and diodes D13 and D14) provides a negative voltage to the negative keyline output circuitry.

## **OUTPUT CIRCUITRY**

Bit 7 of port 5 is normally high. This causes transistor Q9 to conduct and keeps positive keying transistor Q11 off. At the same time, transistor Q12 is on and keeps negative keying transistor Q13 off. When bit 7 goes low, these conditions reverse and both keyline outputs conduct. Diodes D11 and D12 prevent damage to the output transistors in the event you select the wrong key jack for your transmitter. Capacitors C201 and C202 remove any RF that may be present on these keylines.

## **DISPLAY DRIVERS**

Transistors Q1 through Q8 are connected as constant-current sources to drive the individual segments of the seven-segment displays. The microprocessor sequentially grounds the common cathodes of the displays through transistors Q201 through Q204.

## MEMORY BACKUP CIRCUITRY

Integrated circuits U2, U3, U4, and U5 are 256 × 4 CMOS RAM's which provide 512 bytes of storage. They have a very low power standby mode, which allows them to retain data with a supply voltage as low as 2 volts. This standby mode is selected by bringing chip-enable pins CE2 low. To insure that the data is not lost when the keyboard is unplugged or loses power, transistors Q17 and Q18 and their associated components sense a drop in the supply voltage below the minimum required for voltage regulators U11 and U101 to remain in regulation. When this occurs, the CE2 pins are pulled low.

As the supply voltage falls, capacitor C17 discharges through diode D19. When the voltage drops to approximately 8 volts, transistors Q17 and Q18 turn

off and allow resistor R35 to pull CE2 low. As the output of U11 falls below the backup battery voltage, diode D23 becomes forward biased and diode D22 reverse biased. (Diode D21 makes up for the voltage drop across diode D22 when the CW Keyboard is turned on.) The RAM is then in the standby mode. Since U11 receives voltage whenever the CW Keyboard is connected to a power source, the backup batteries are only switched in when the CW Keyboard loses power.

Keyboard reset is accomplished by turning the keyboard off and simultaneously, removing the backup supply from the RAM. This forces the program to clear RAM and initialize settings whenever the power is again turned on.



# CIRCUIT BOARD X-RAY VIEWS

Note: to find the PART NUMBER of a component for the purpose of ordering a replacement part:

- A. Find the circuit component number (R5, C3, etc.) on the "X-Ray View."
- B. Locate this same number in the "Circuit Component Number" column of the "Parts List."
- C. Adjacent to the circuit component number, you will find the PART NUMBER and description which must be supplied when you order a replacement part.

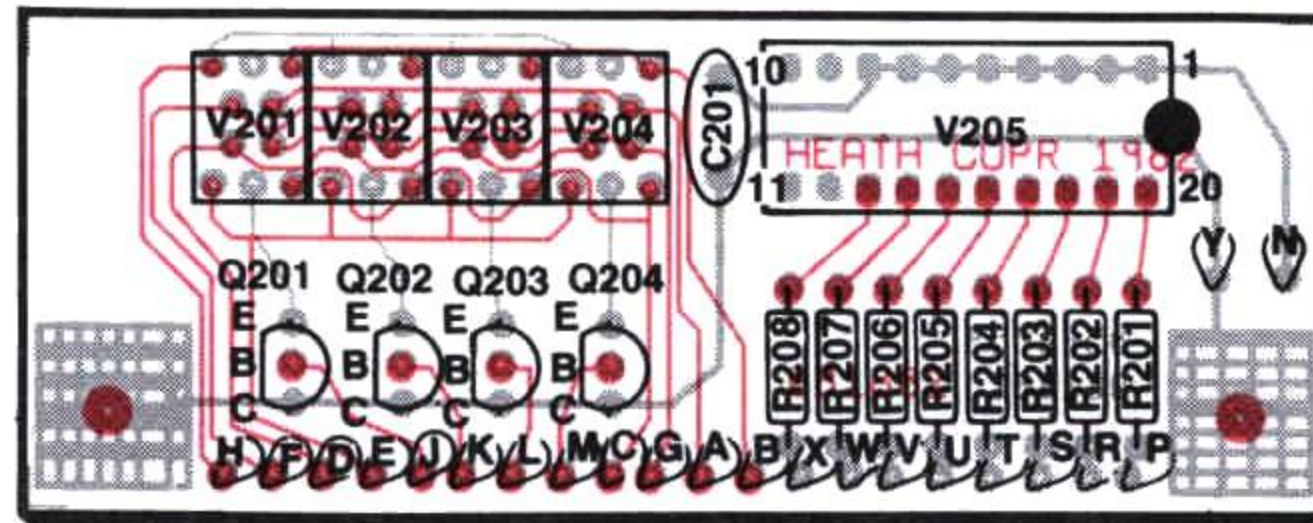

**DISPLAY CIRCUIT BOARD**  
 (Shown from the component side. The foil on the component side is shown in red.)

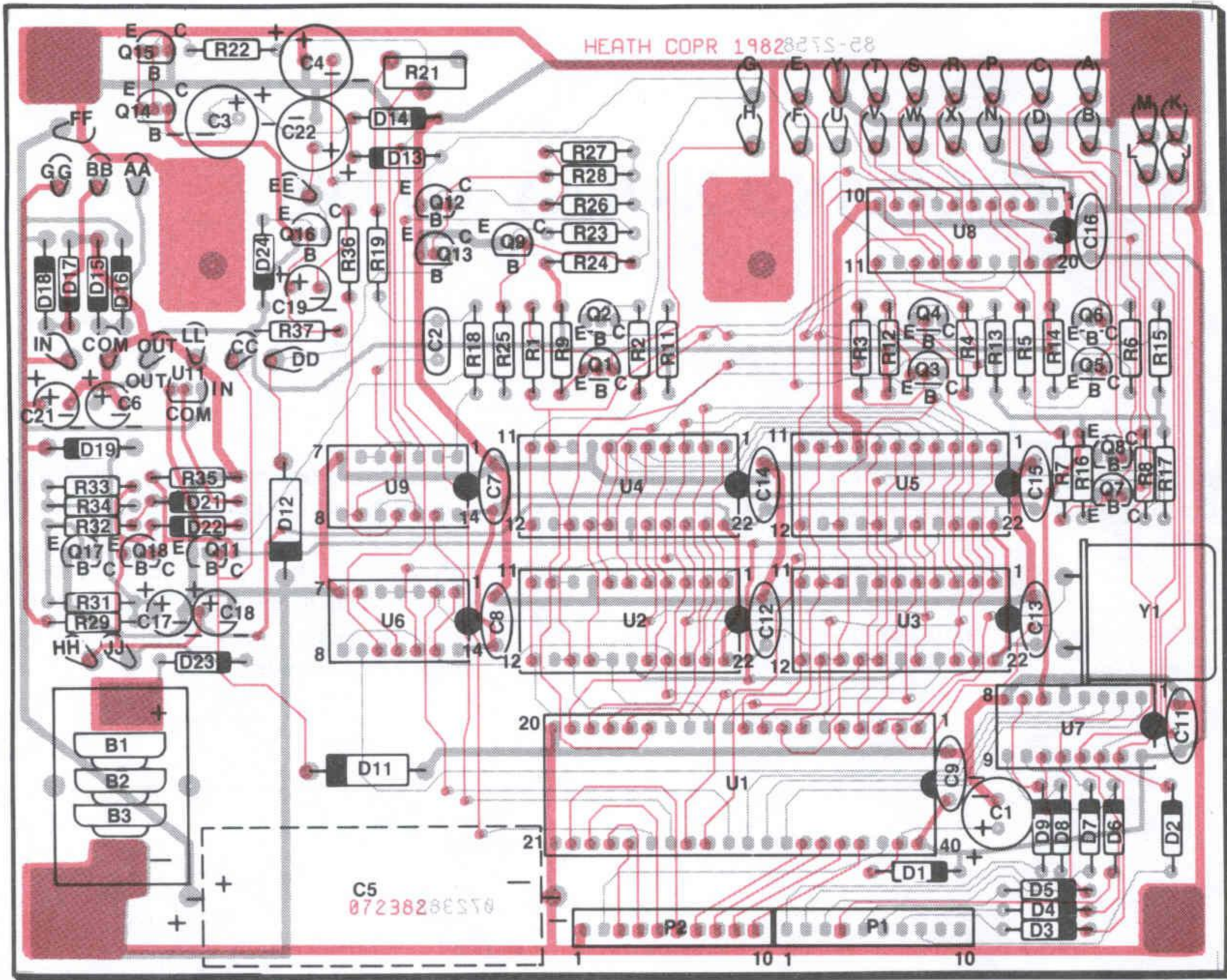

**MAIN CIRCUIT BOARD**

(Shown from the component side. The foil on the component side is shown in red.)

# SEMICONDUCTOR IDENTIFICATION CHARTS

## DIODES – LED's

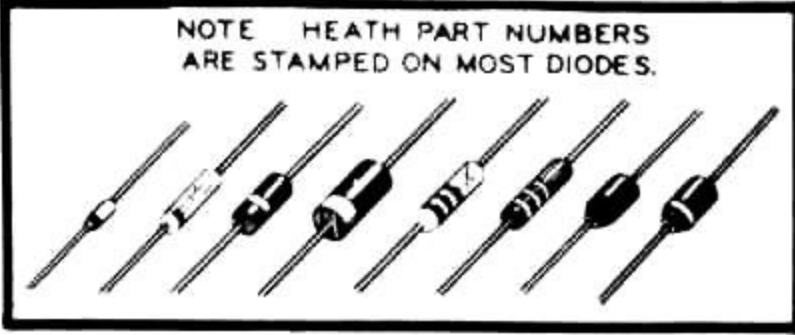
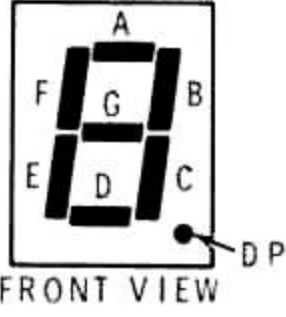
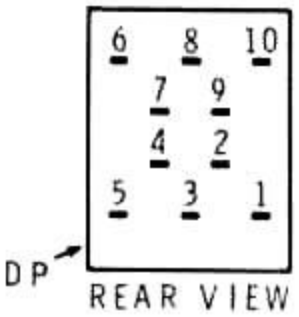
HEATH PART NUMBER	MAY BE REPLACED WITH	CIRCUIT COMPONENT NUMBER	IDENTIFICATION																						
56-26	1N191	D2, D3, D4, D5, D6, D7, D8, D9																							
56-56	1N4149	D1, D19, D22, D24																							
56-89	GD510	D13, D14, D23																							
57-64	DRS110	D11, D12																							
57-65	1N4002	D15, D16, D17, D18																							
411-861	HD-1077G	V201, V202, V203, V204	 <p>FRONT VIEW</p>  <p>REAR VIEW</p> <table border="0"> <thead> <tr> <th>PIN</th> <th>FUNCTION</th> </tr> </thead> <tbody> <tr> <td>1</td> <td>ANODE SEGMENT E</td> </tr> <tr> <td>2</td> <td>ANODE SEGMENT D</td> </tr> <tr> <td>3</td> <td>COMMON CATHODE</td> </tr> <tr> <td>4</td> <td>ANODE SEGMENT C</td> </tr> <tr> <td>5</td> <td>ANODE DECIMAL POINT</td> </tr> <tr> <td>6</td> <td>ANODE SEGMENT B</td> </tr> <tr> <td>7</td> <td>ANODE SEGMENT A</td> </tr> <tr> <td>8</td> <td>COMMON CATHODE</td> </tr> <tr> <td>9</td> <td>ANODE SEGMENT G</td> </tr> <tr> <td>10</td> <td>ANODE SEGMENT F</td> </tr> </tbody> </table>	PIN	FUNCTION	1	ANODE SEGMENT E	2	ANODE SEGMENT D	3	COMMON CATHODE	4	ANODE SEGMENT C	5	ANODE DECIMAL POINT	6	ANODE SEGMENT B	7	ANODE SEGMENT A	8	COMMON CATHODE	9	ANODE SEGMENT G	10	ANODE SEGMENT F
PIN	FUNCTION																								
1	ANODE SEGMENT E																								
2	ANODE SEGMENT D																								
3	COMMON CATHODE																								
4	ANODE SEGMENT C																								
5	ANODE DECIMAL POINT																								
6	ANODE SEGMENT B																								
7	ANODE SEGMENT A																								
8	COMMON CATHODE																								
9	ANODE SEGMENT G																								
10	ANODE SEGMENT F																								

**DIODES – LED's (Cont'd.)**

HEATH PART NUMBER	MAY BE REPLACED WITH	CIRCUIT COMPONENT NUMBER	IDENTIFICATION
411-862		V205	

**TRANSISTORS**

HEATH PART NUMBER	MAY BE REPLACED WITH	CIRCUIT COMPONENT NUMBER	IDENTIFICATION
417-235	2N4121	Q12, Q18	
417-294	MPSA42	Q11	
417-801	MPSA20	Q9, Q17	
417-864	MPSA05	Q14	
417-865	MPSA55	Q1, Q2, Q3, Q4, Q5, Q6, Q7, Q8, Q15, Q16, Q201, Q202, Q203, Q204	
417-927	MPSA93	Q13	

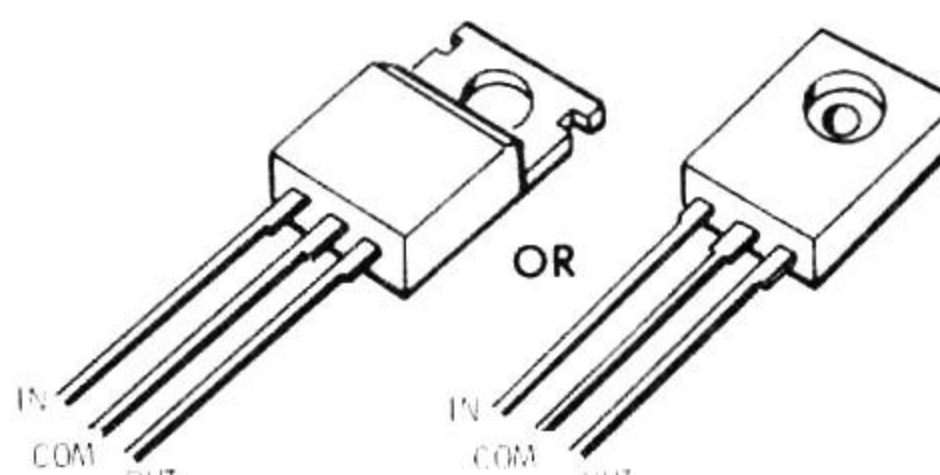
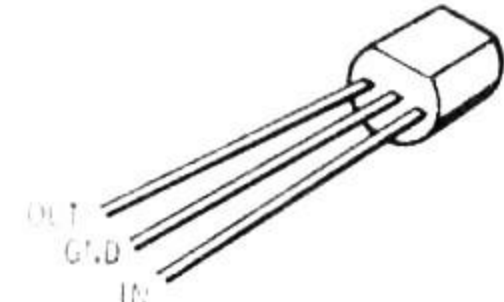
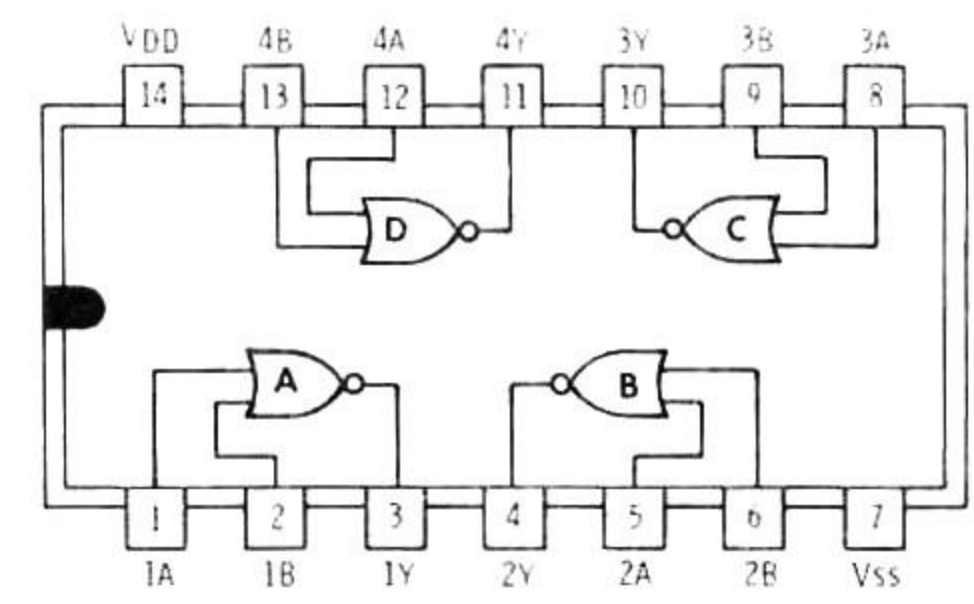
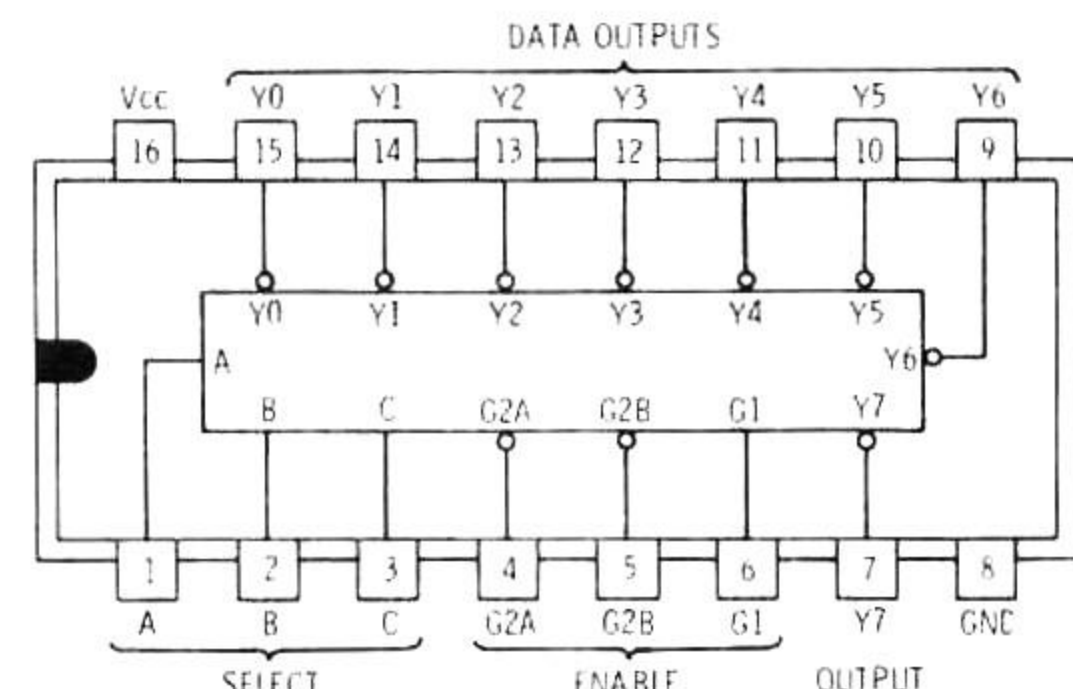
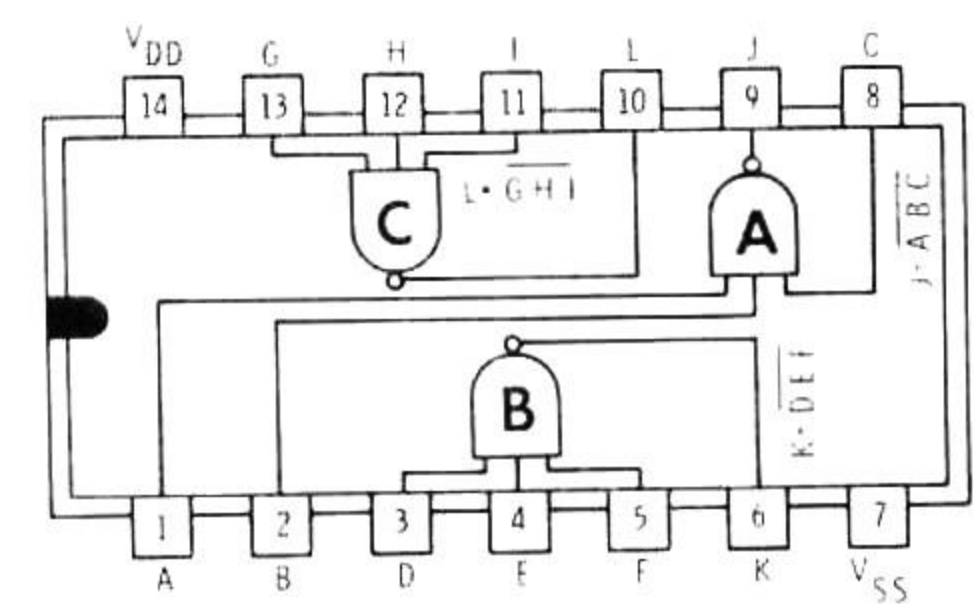

## INTEGRATED CIRCUITS

HEATH PART NUMBER	MAY BE REPLACED WITH	CIRCUIT COMPONENT NUMBER	IDENTIFICATION
442-54	7805	U101	
442-627	78L05	U11	
443-703	MC14001CP	U9	
443-877	74LS138	U7	
443-887	4023	U6	

INTEGRATED CIRCUITS (Cont'd.)

HEATH PART NUMBER	MAY BE REPLACED WITH	CIRCUIT COMPONENT NUMBER	IDENTIFICATION
443-933	5101	U2, U3, U4, U5	
443-1110	74LS377	U8	
444-186	MK3870*	U1	

\*This is a custom integrated circuit. Replace it only with a replacement part from the Heath Company.

# ILLUSTRATION BOOKLET

## DISPLAY CIRCUIT BOARD PARTS PICTORIAL

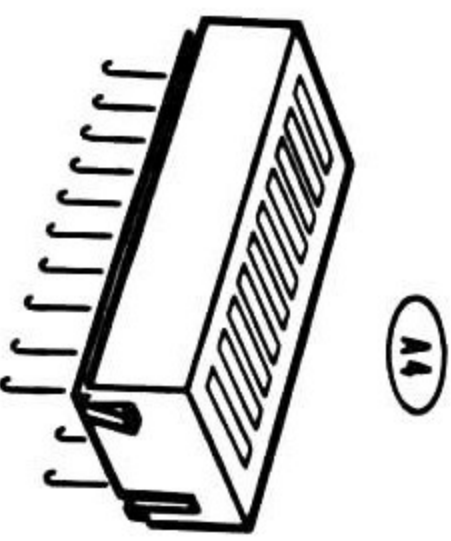
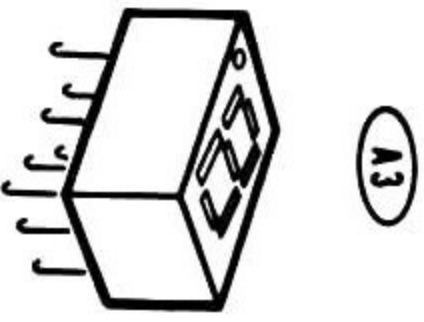
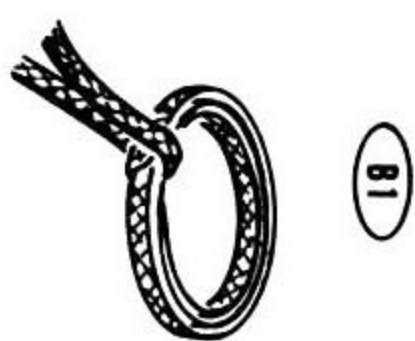
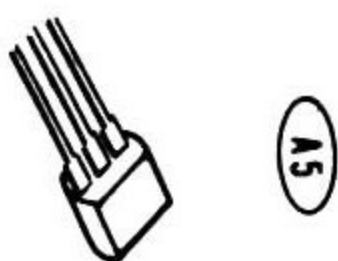
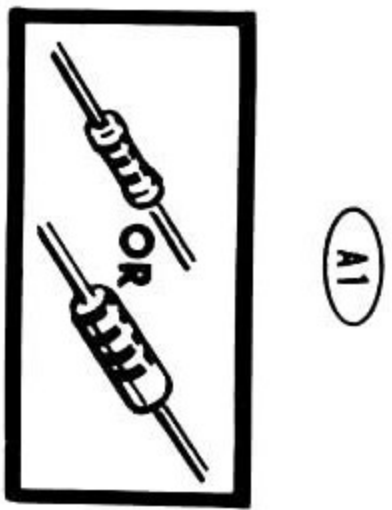

# MAIN CIRCUIT BOARD PARTS PICTORIAL

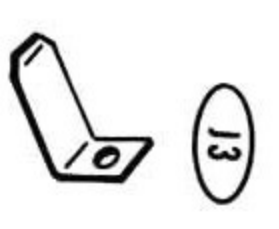
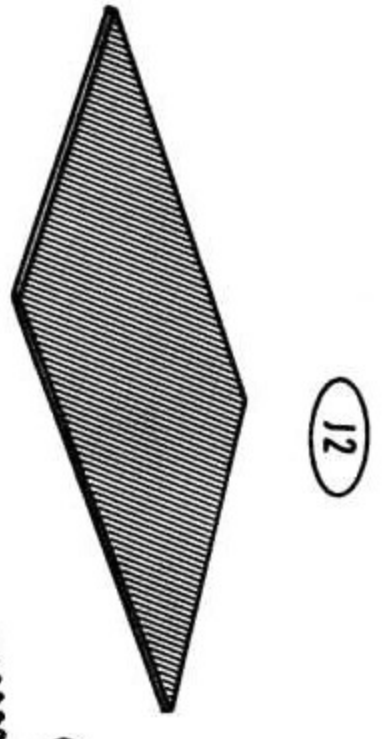
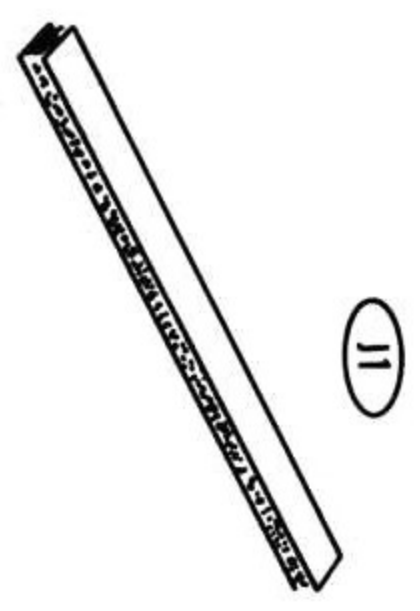
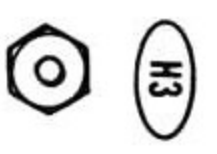
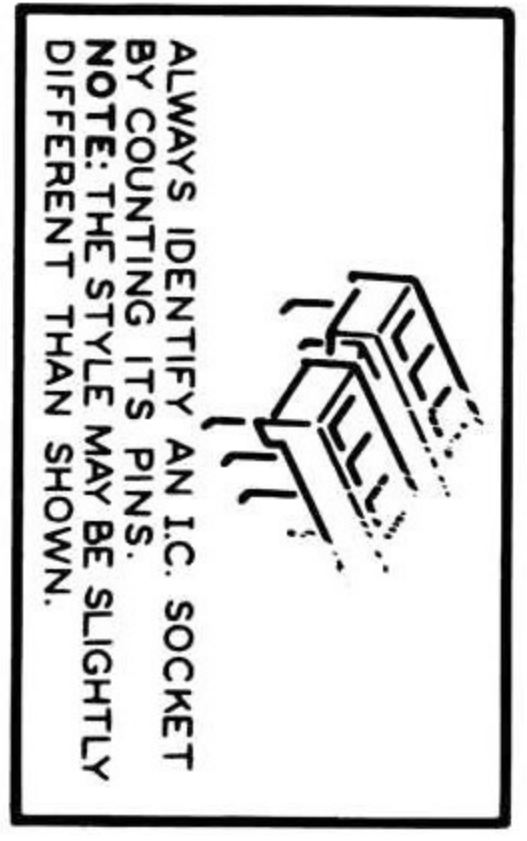
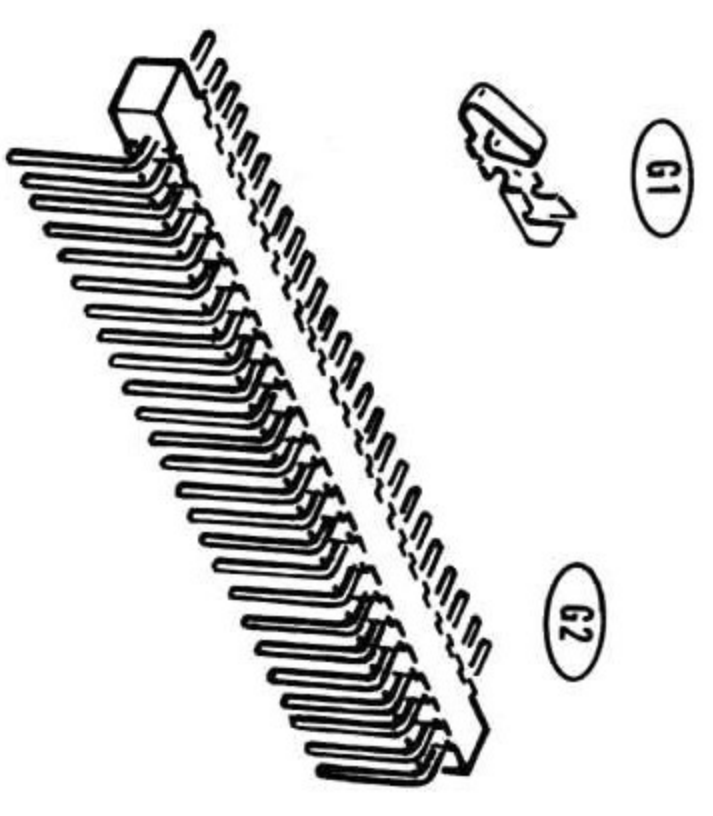
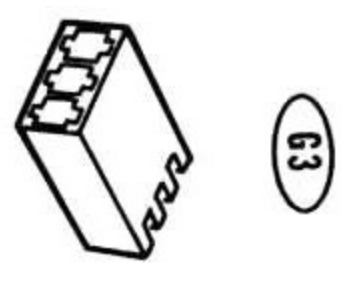
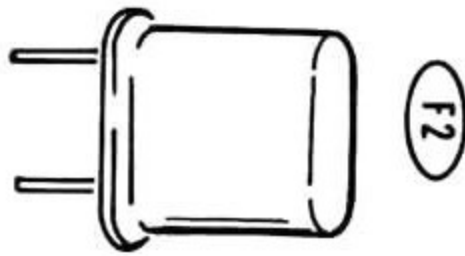
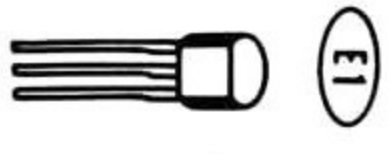
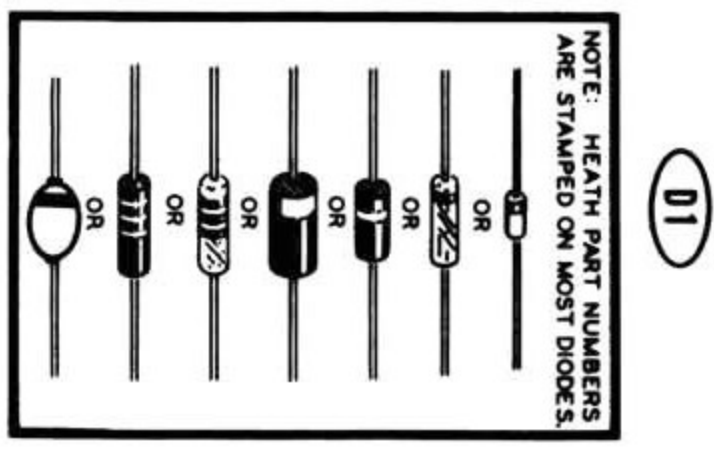
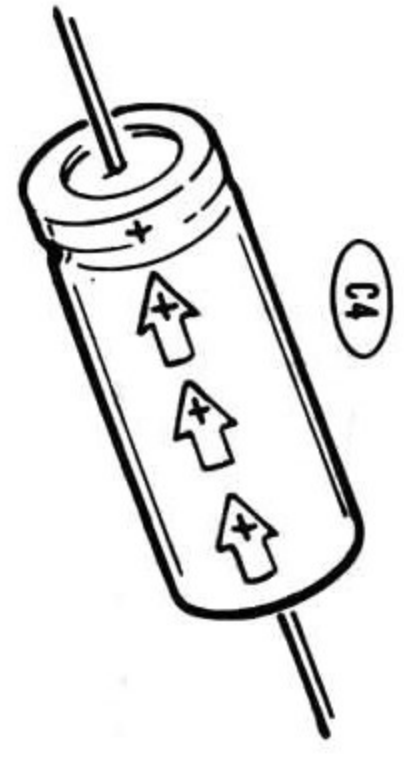
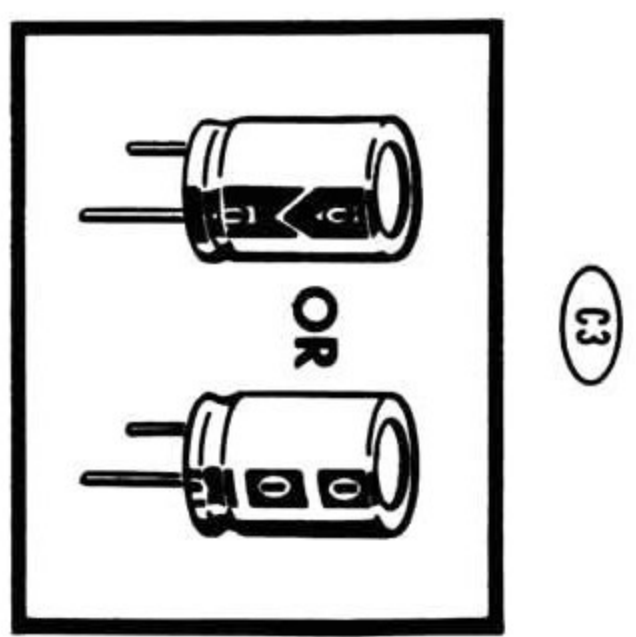
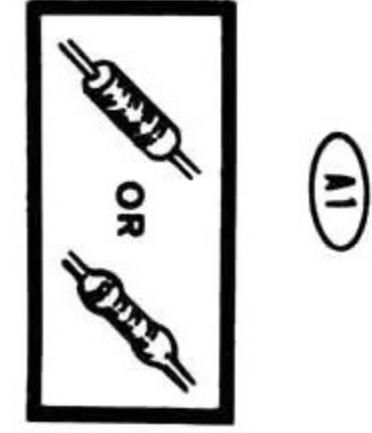

ALWAYS IDENTIFY AN I.C. BY THE PART NUMBER OR TYPE NUMBER  
NOTE: THE STYLE MAY BE SLIGHTLY DIFFERENT THAN SHOWN.



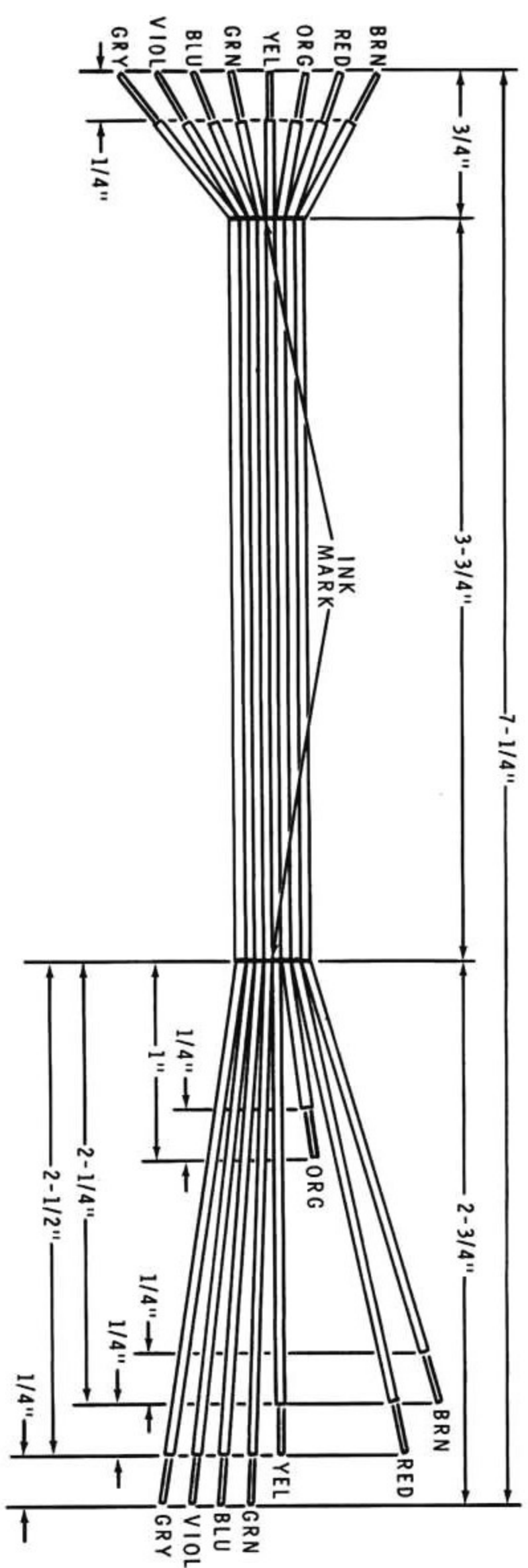
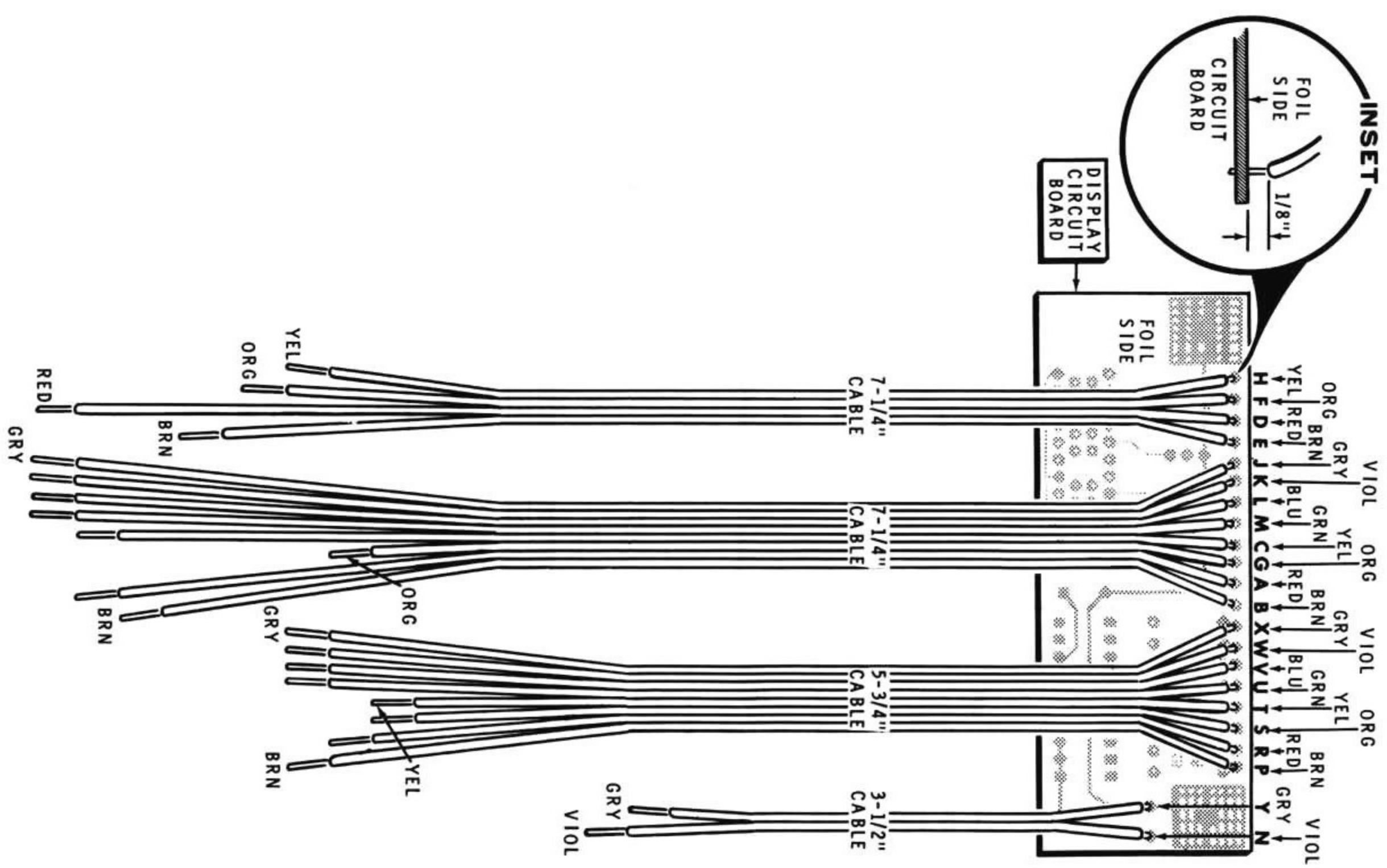

PICTORIAL 2-7

Detail 2-7B

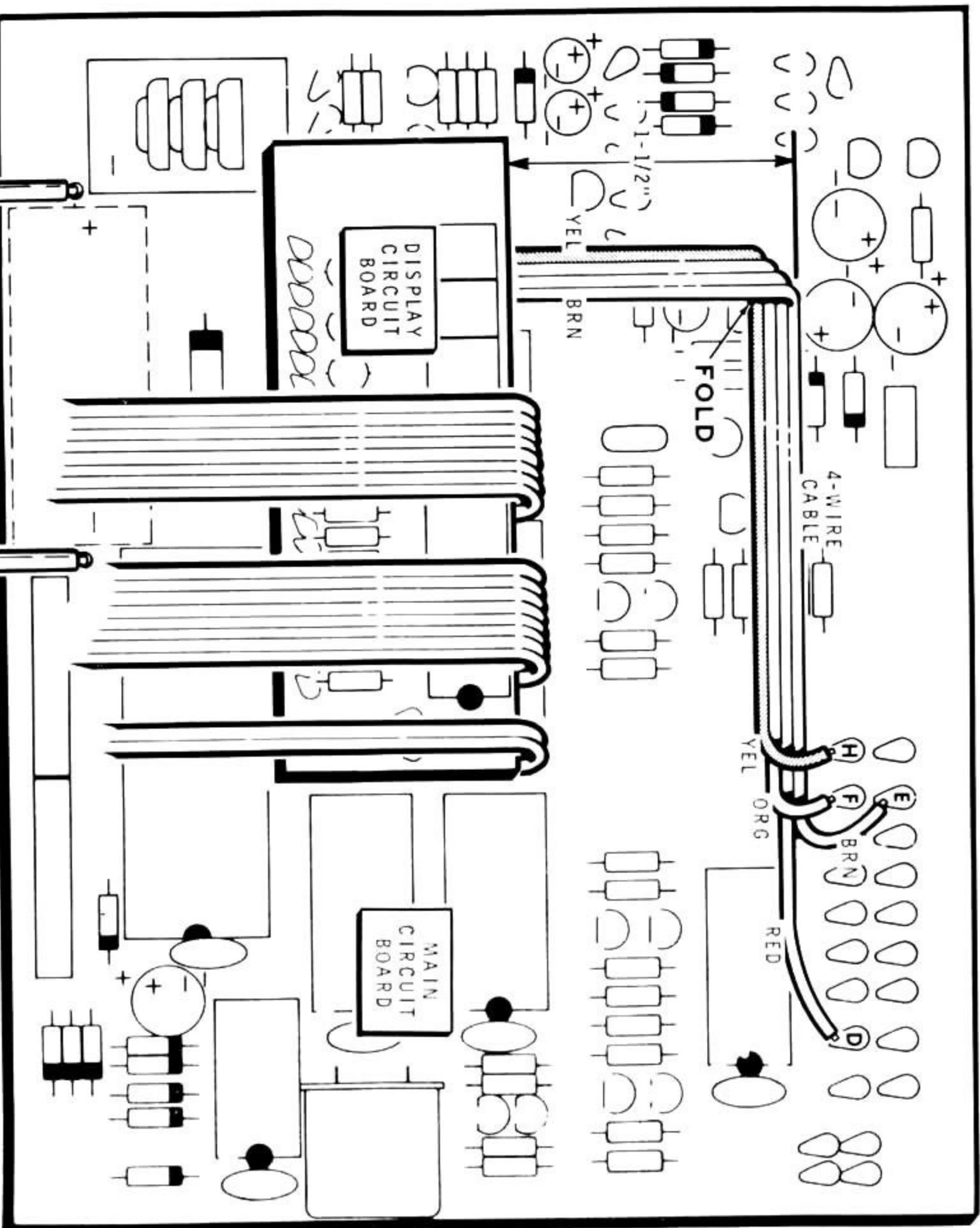
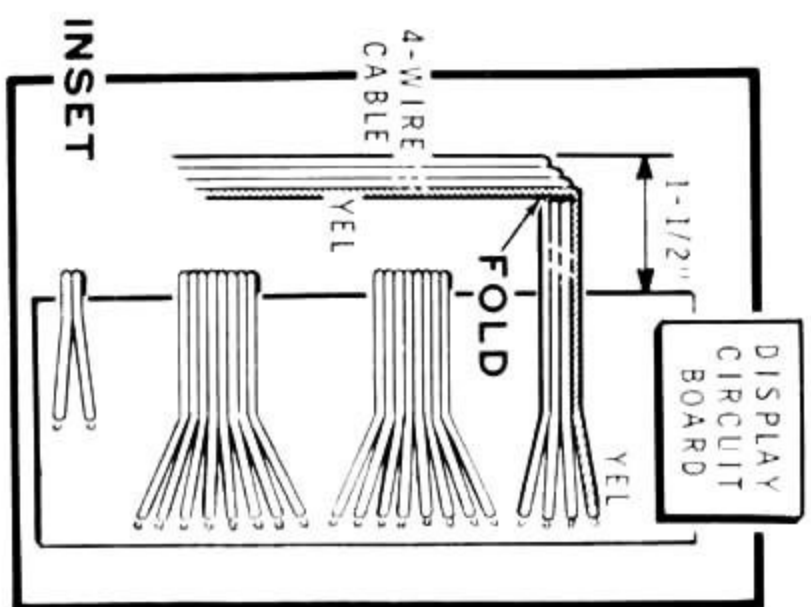

PICTORIAL 2-8

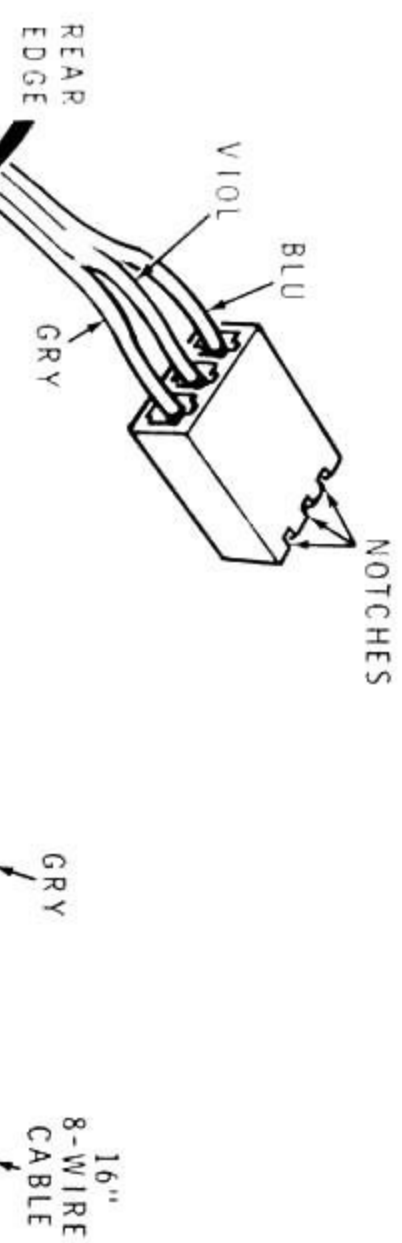
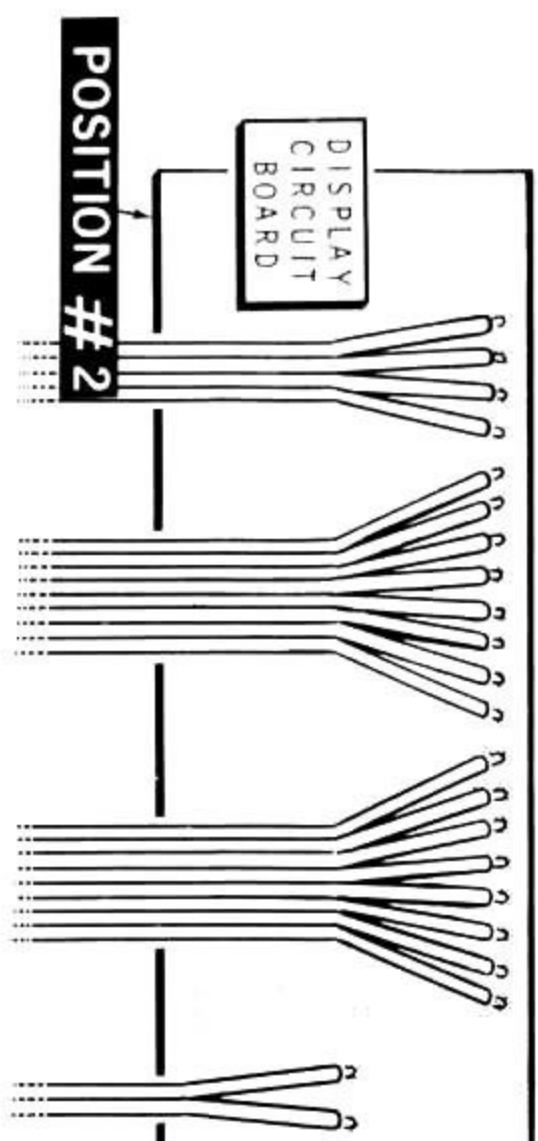

16" 8-WIRE CABLE

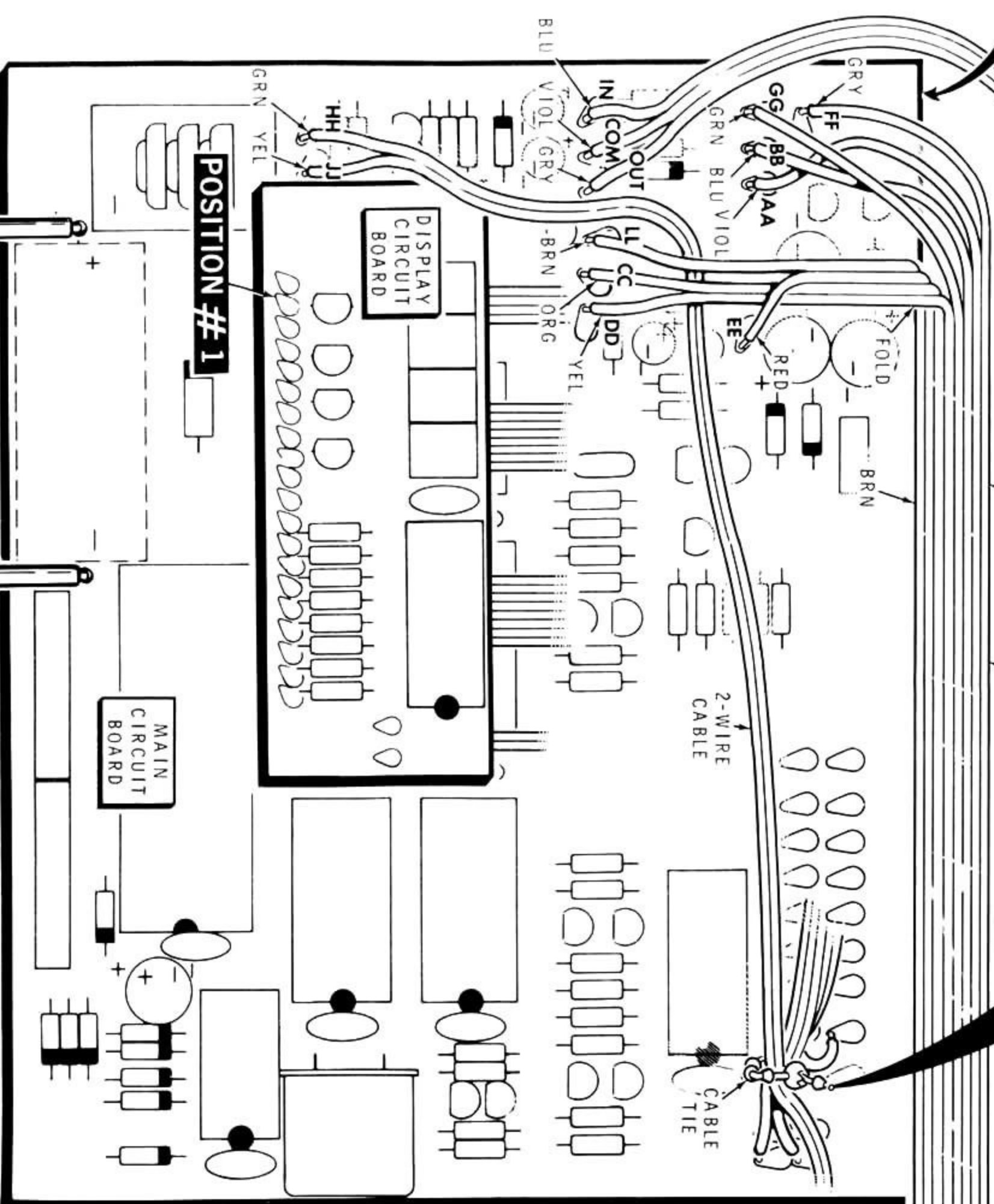
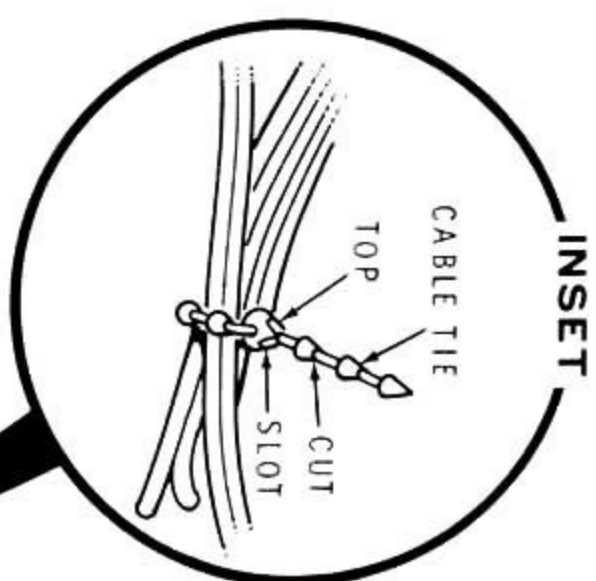

PICTORIAL 2-11

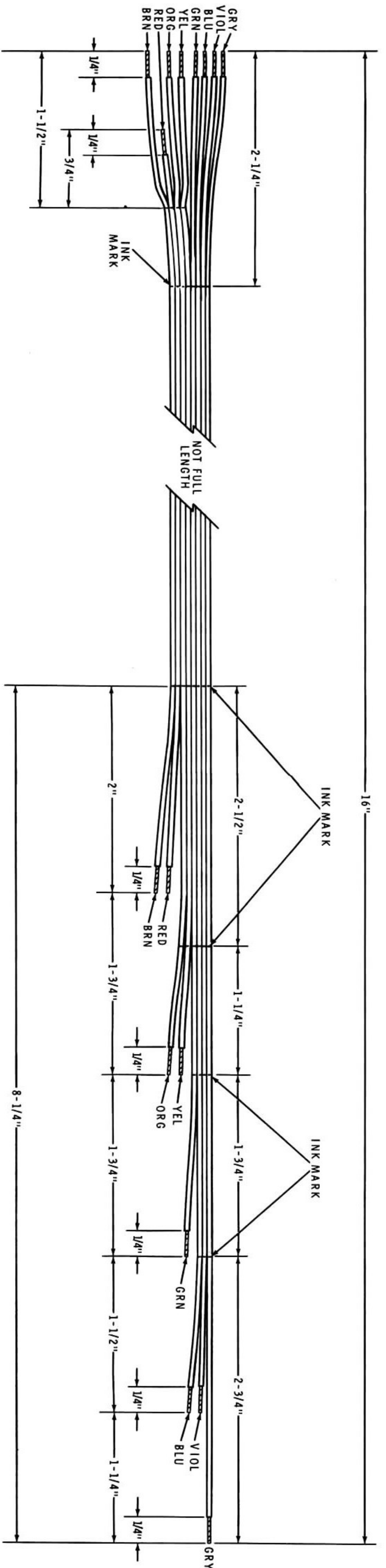

**Detail 2-11A**

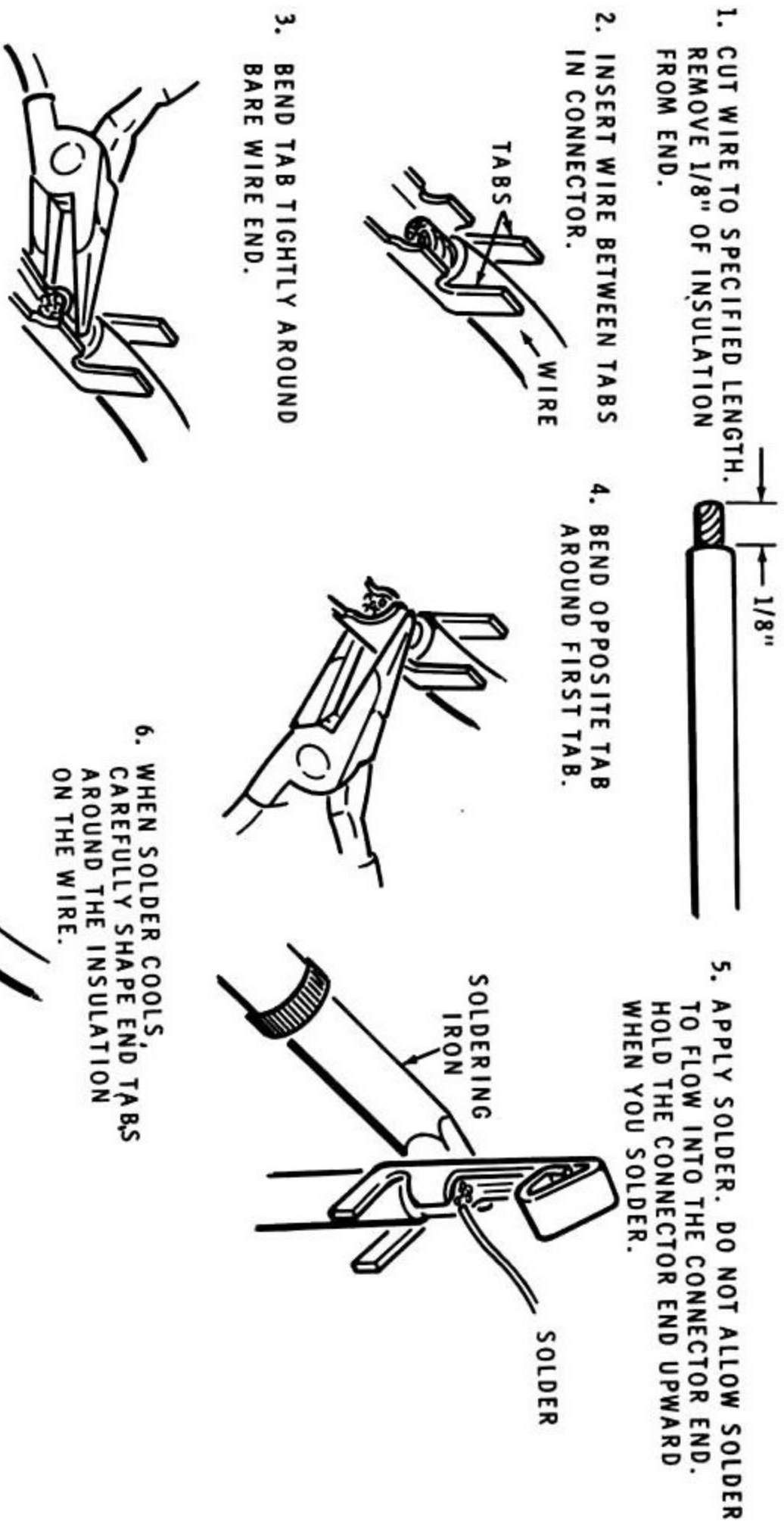

**Detail 2-11C**

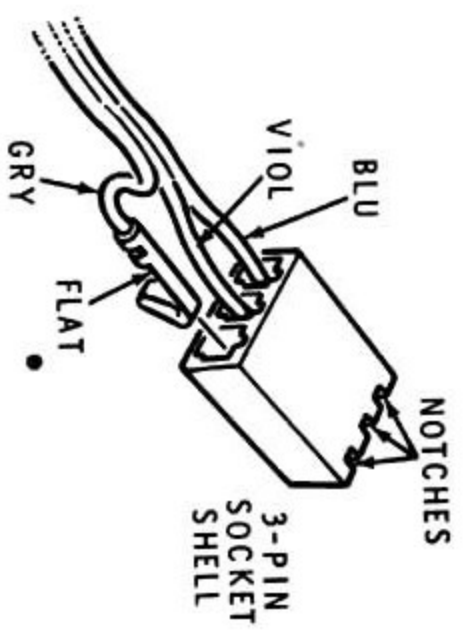
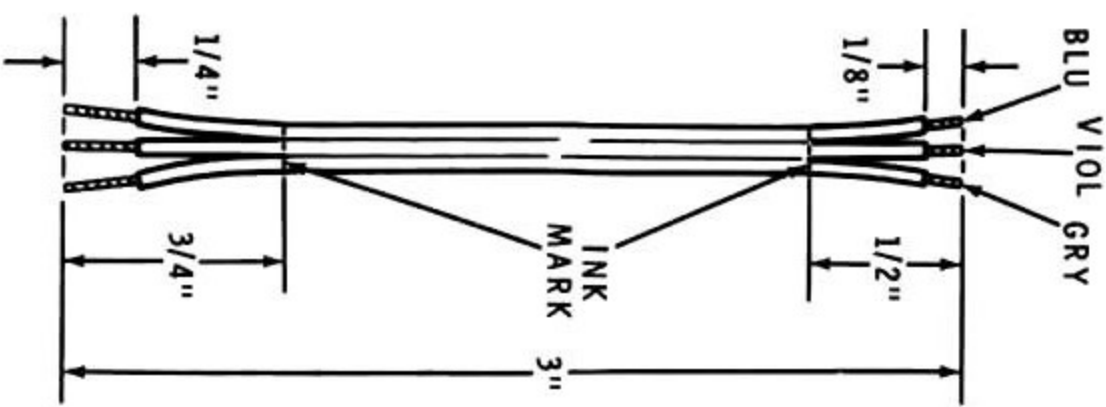

1. CUT WIRE TO SPECIFIED LENGTH. REMOVE 1/8" OF INSULATION FROM END.
2. INSERT WIRE BETWEEN TABS IN CONNECTOR.
3. BEND TAB TIGHTLY AROUND BARE WIRE END.
4. BEND OPPOSITE TAB AROUND FIRST TAB.
5. APPLY SOLDER. DO NOT ALLOW SOLDER TO FLOW INTO THE CONNECTOR END. HOLD THE CONNECTOR END UPWARD WHEN YOU SOLDER.
6. WHEN SOLDER COOLS, CAREFULLY SHAPE END TABS AROUND THE INSULATION ON THE WIRE.



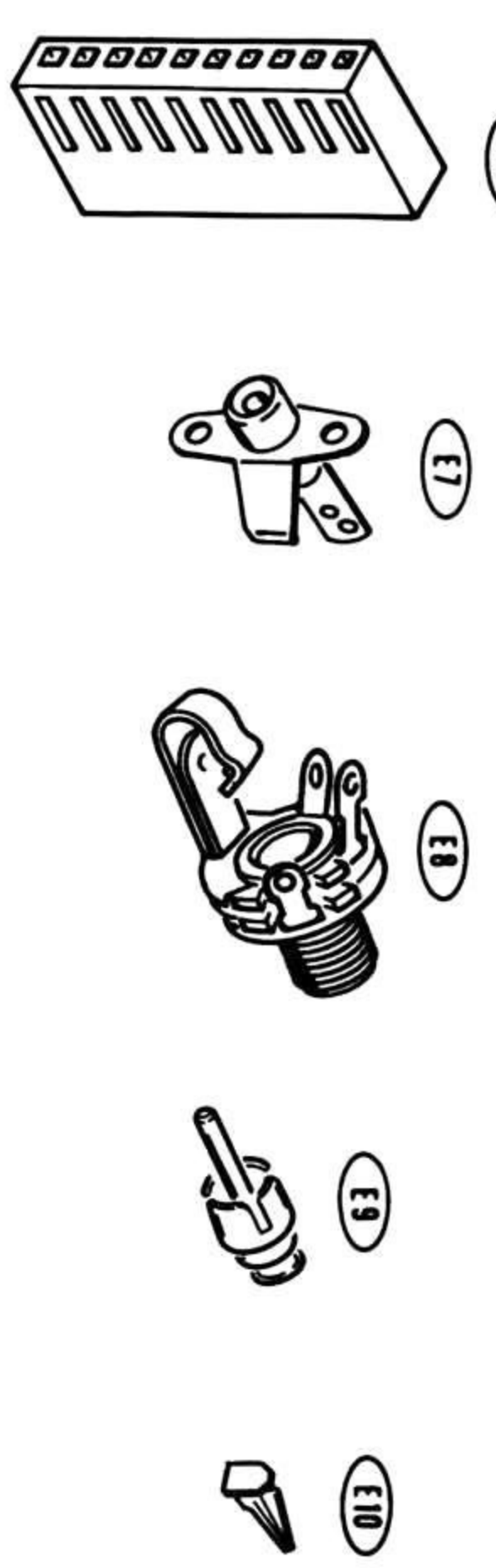
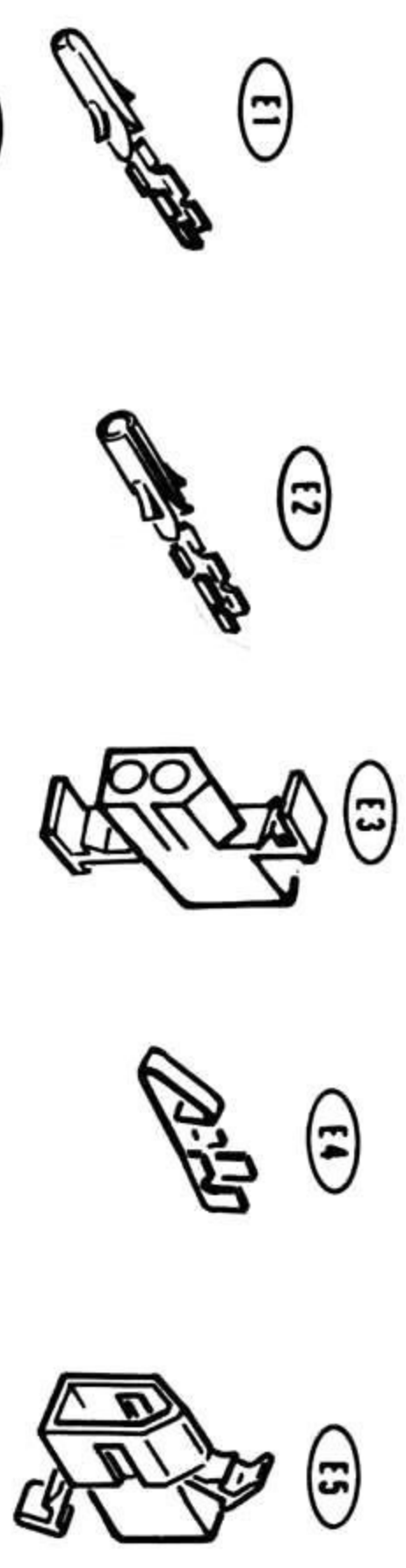
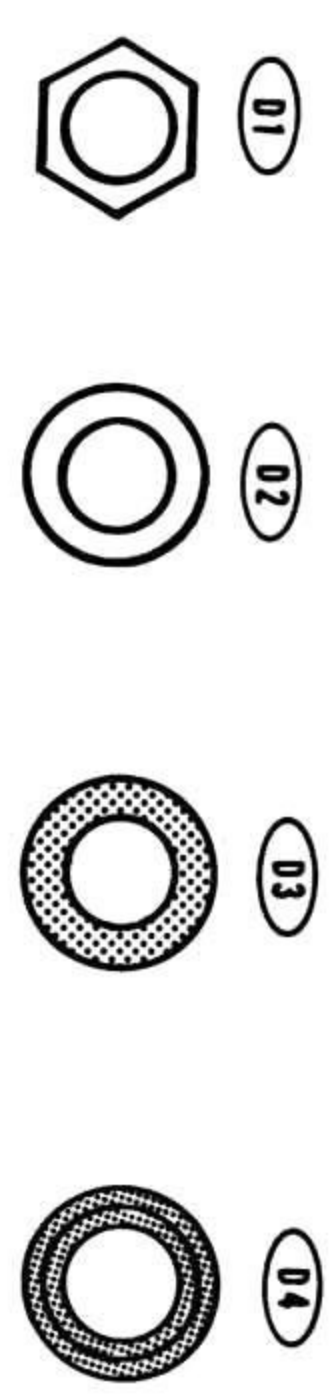
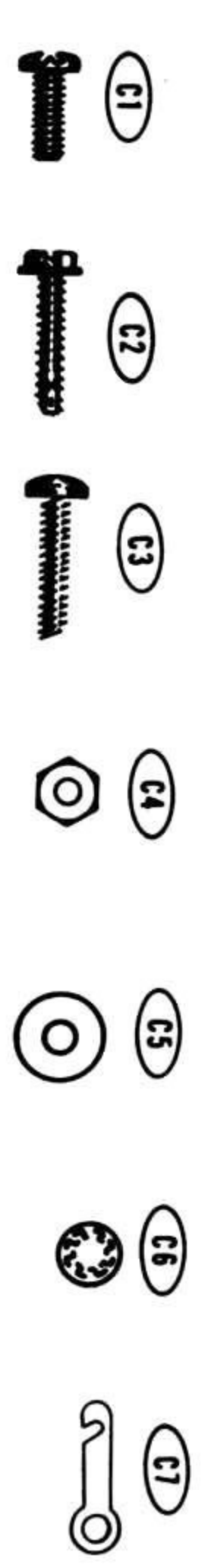
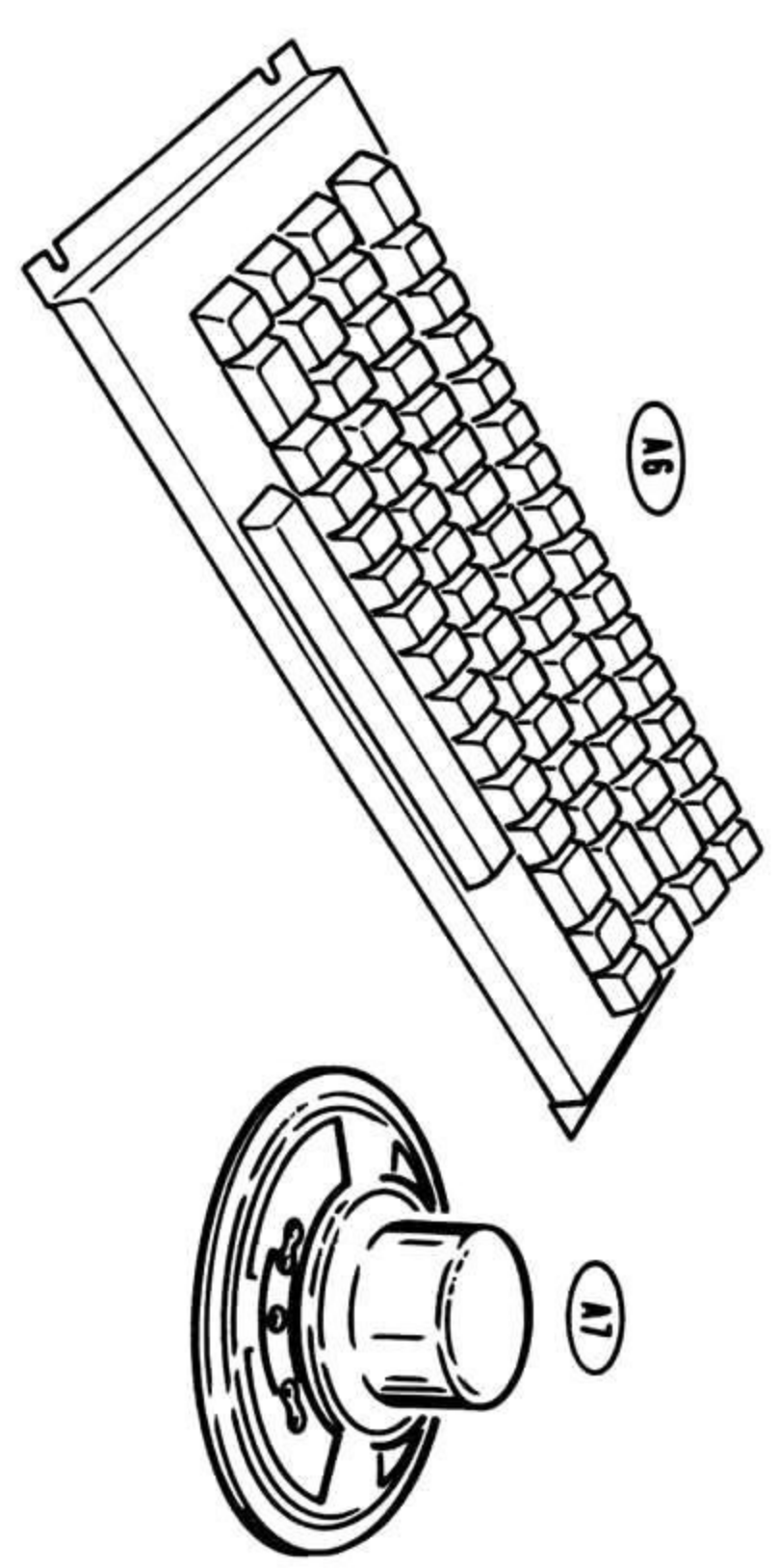
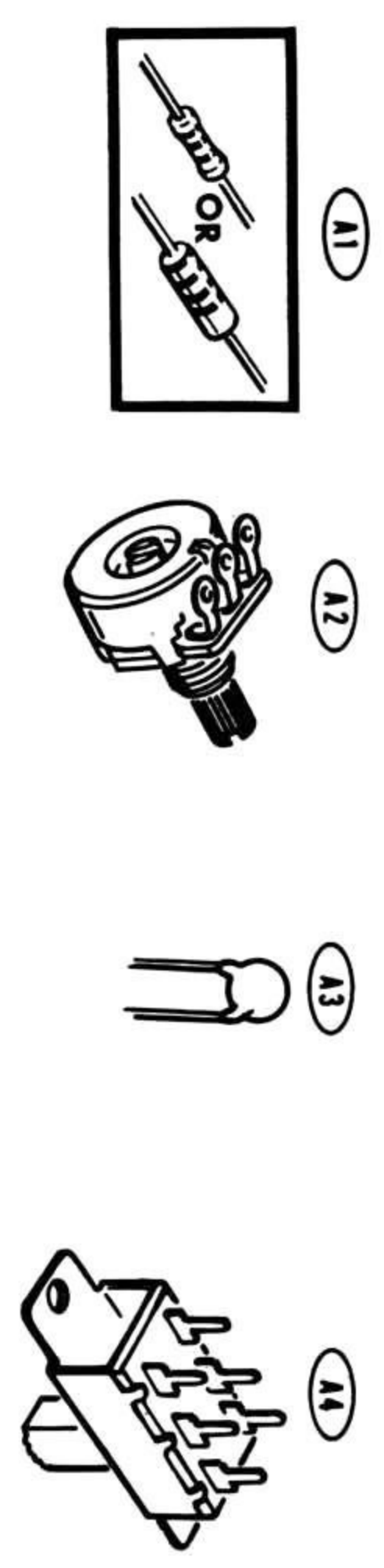



Chassis Parts Pictorial (Cont'd.)

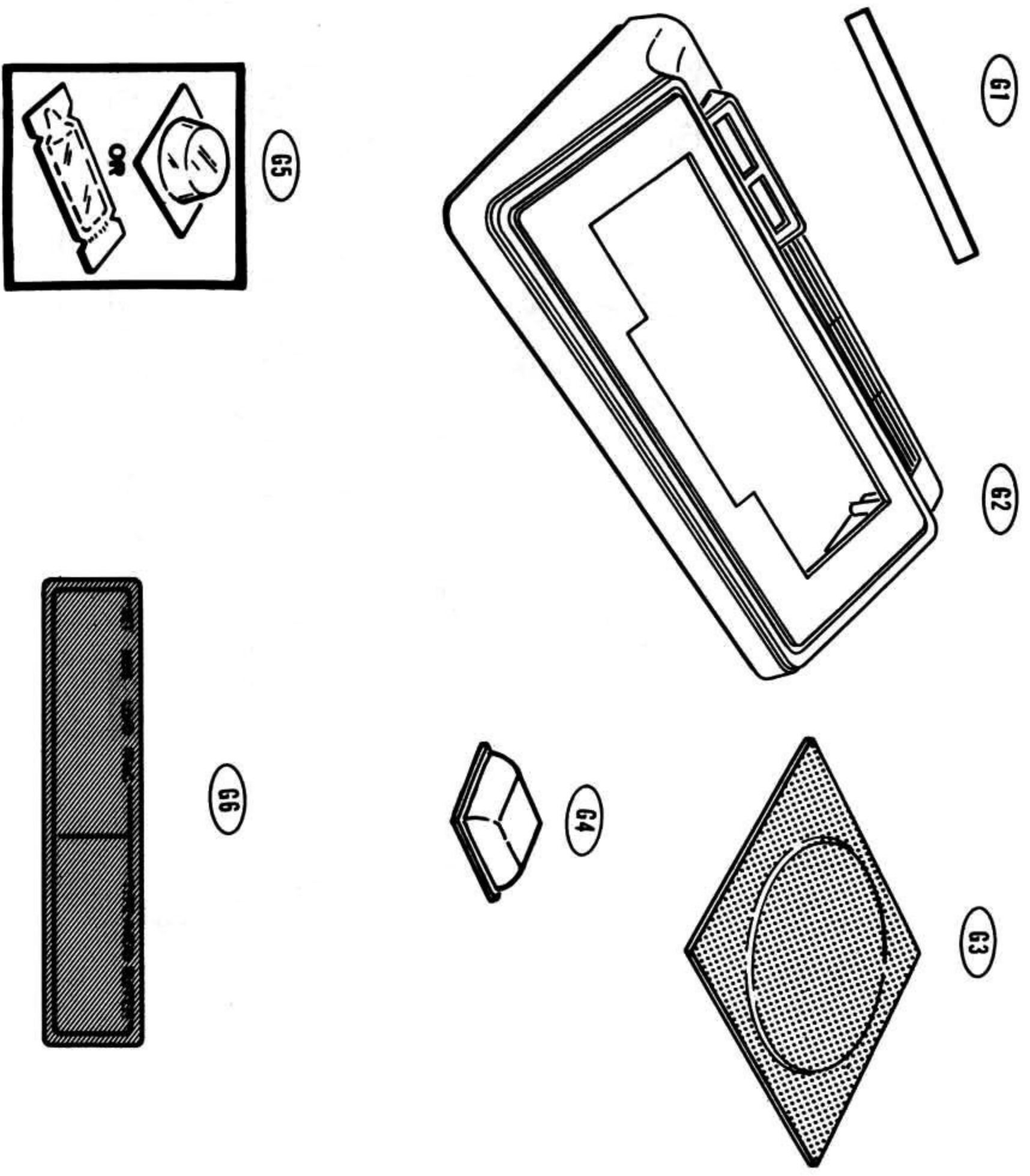
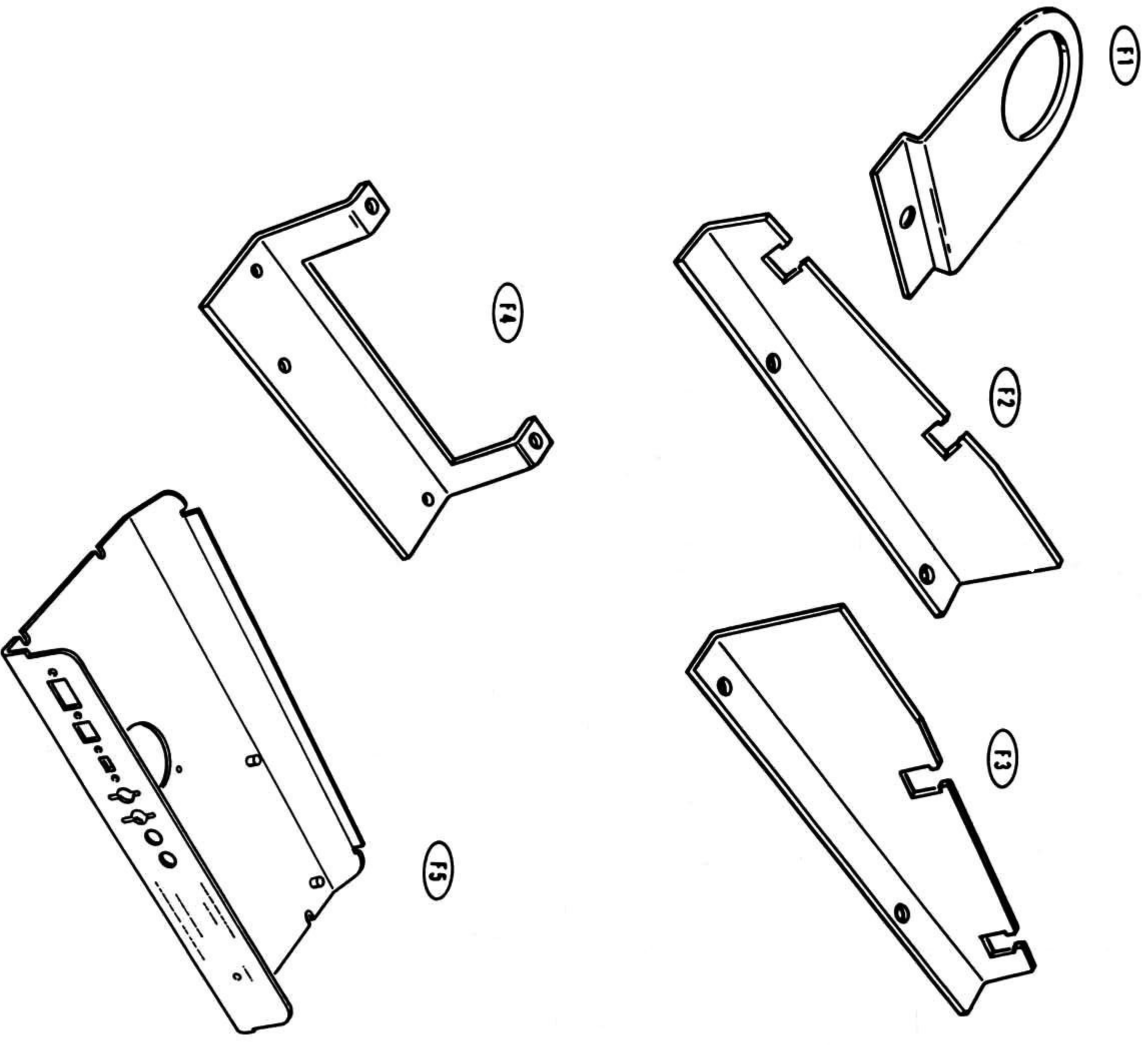

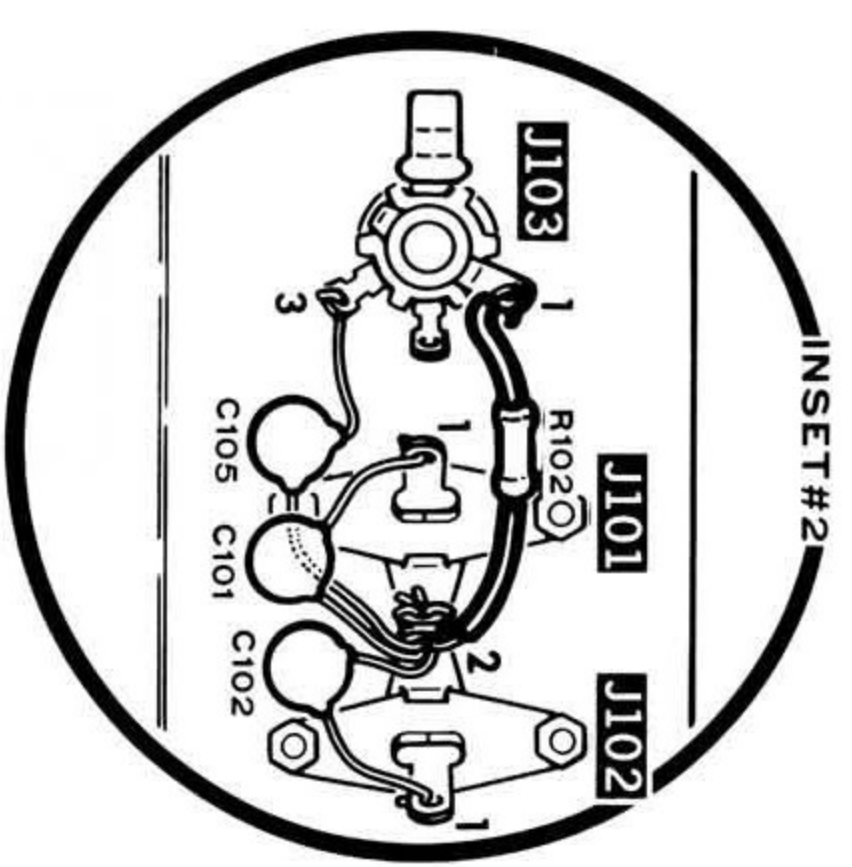
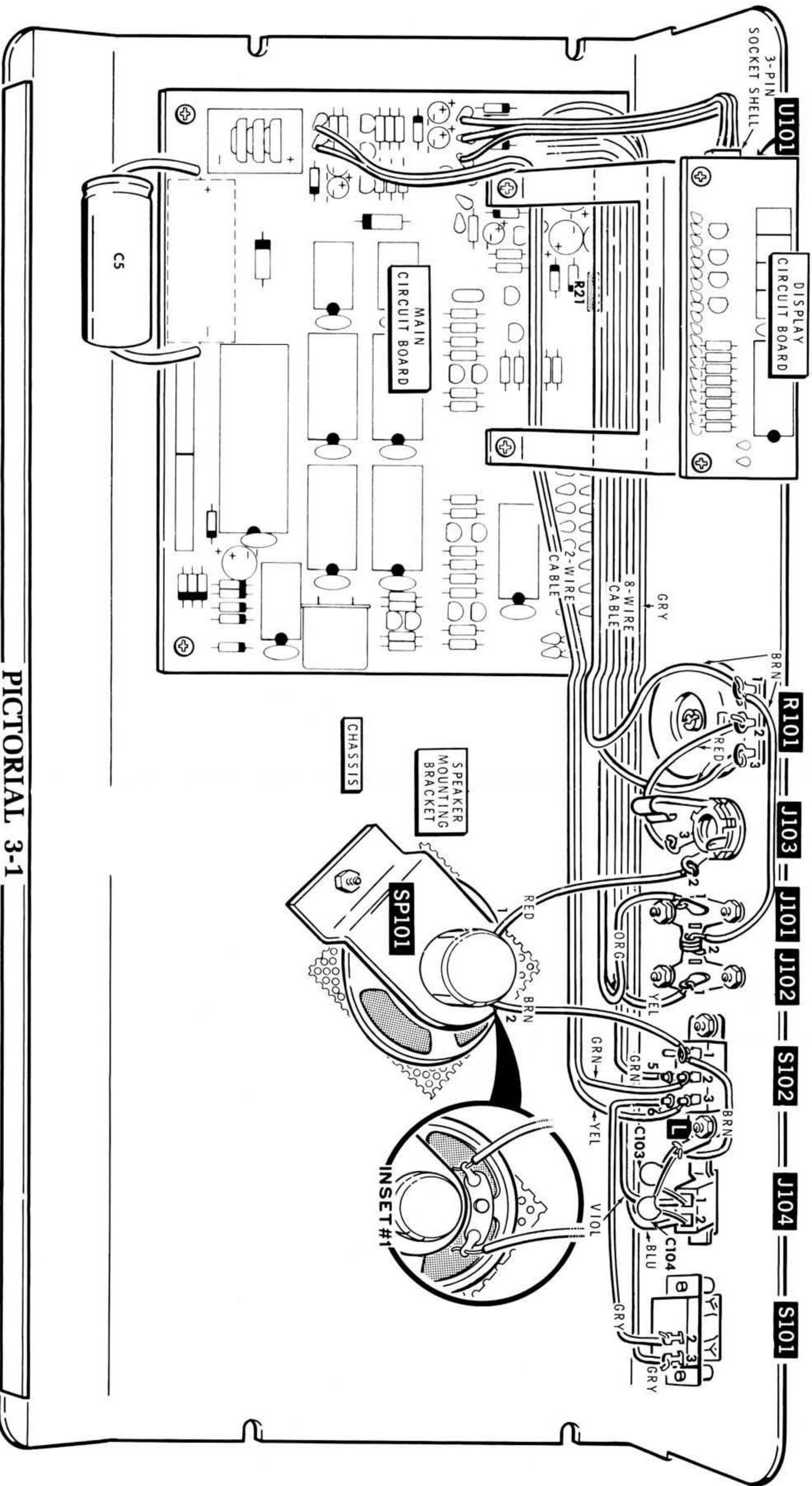

PICTORIAL 3-1

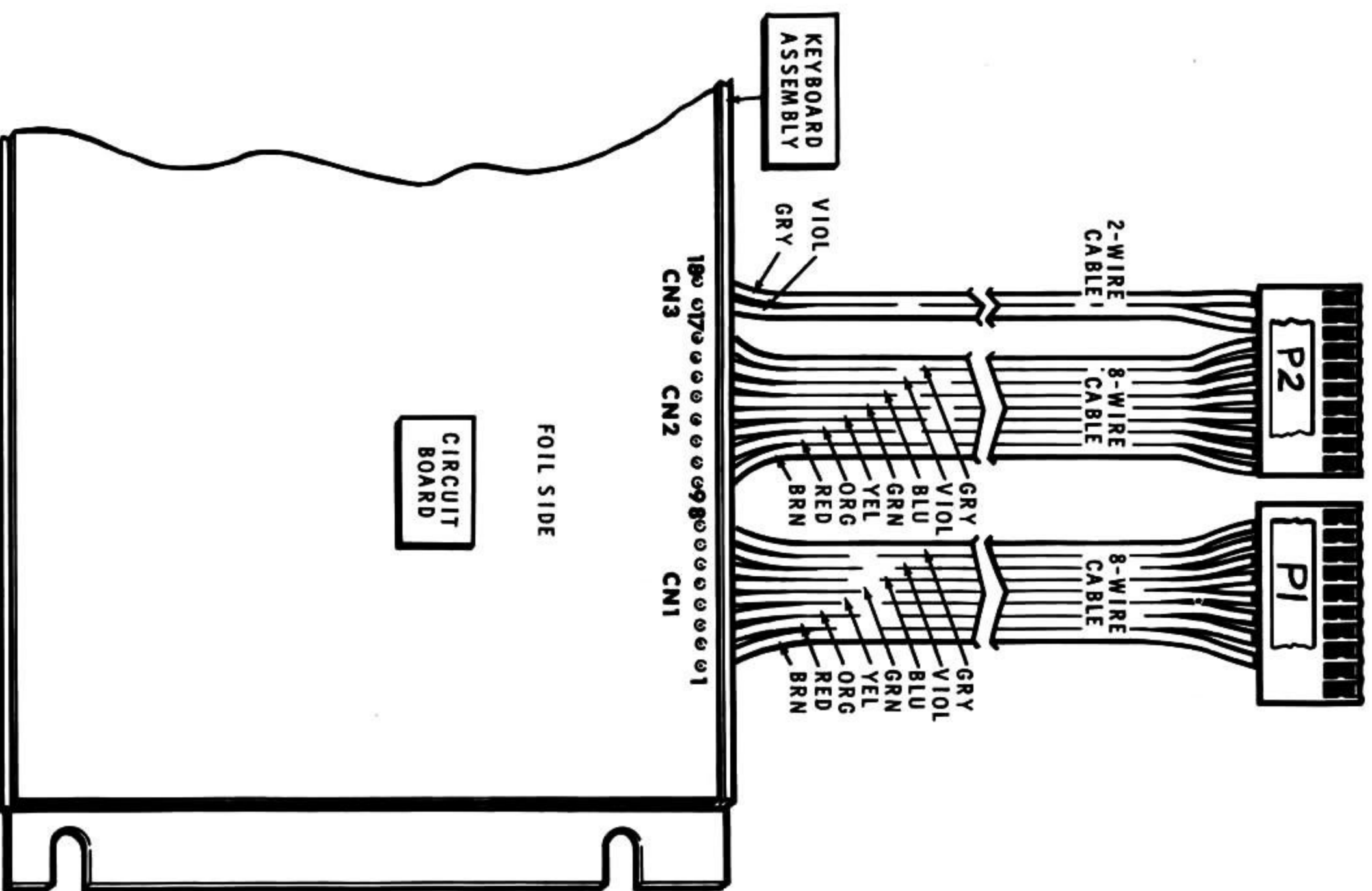

PICTORIAL 3-2

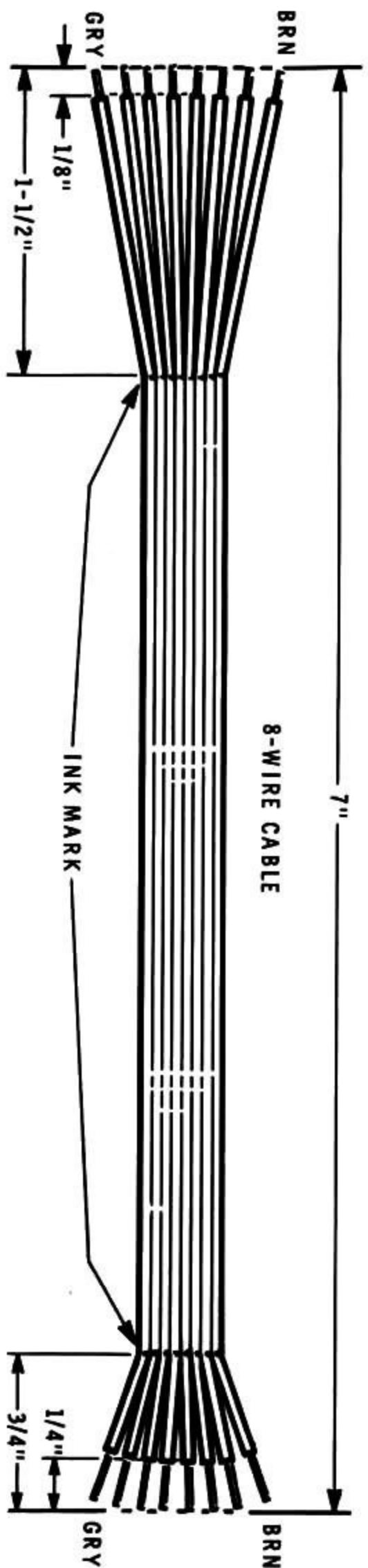

Detail 3-2A

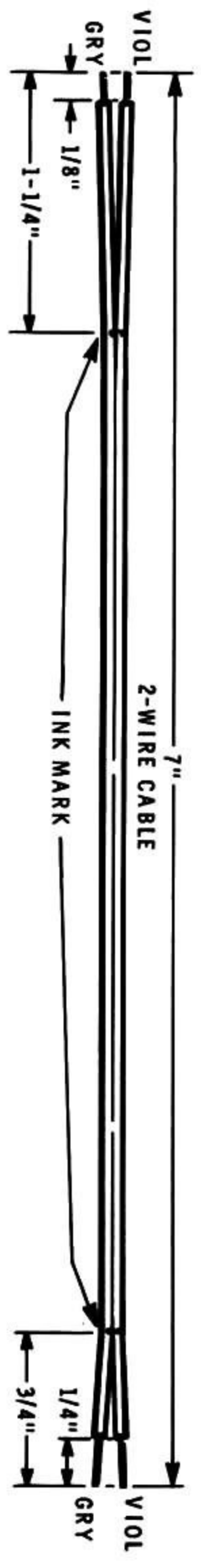

Detail 3-2B

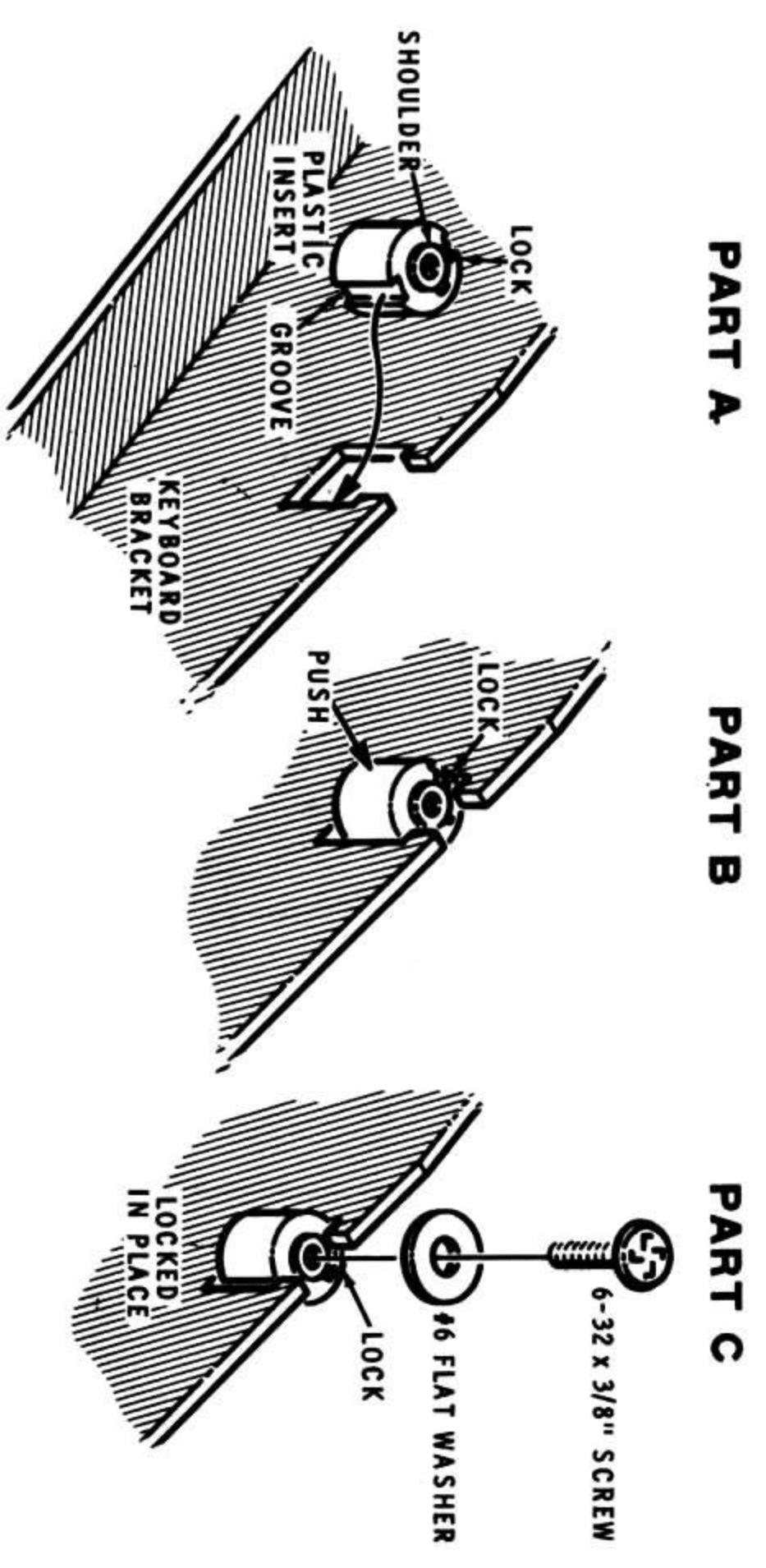
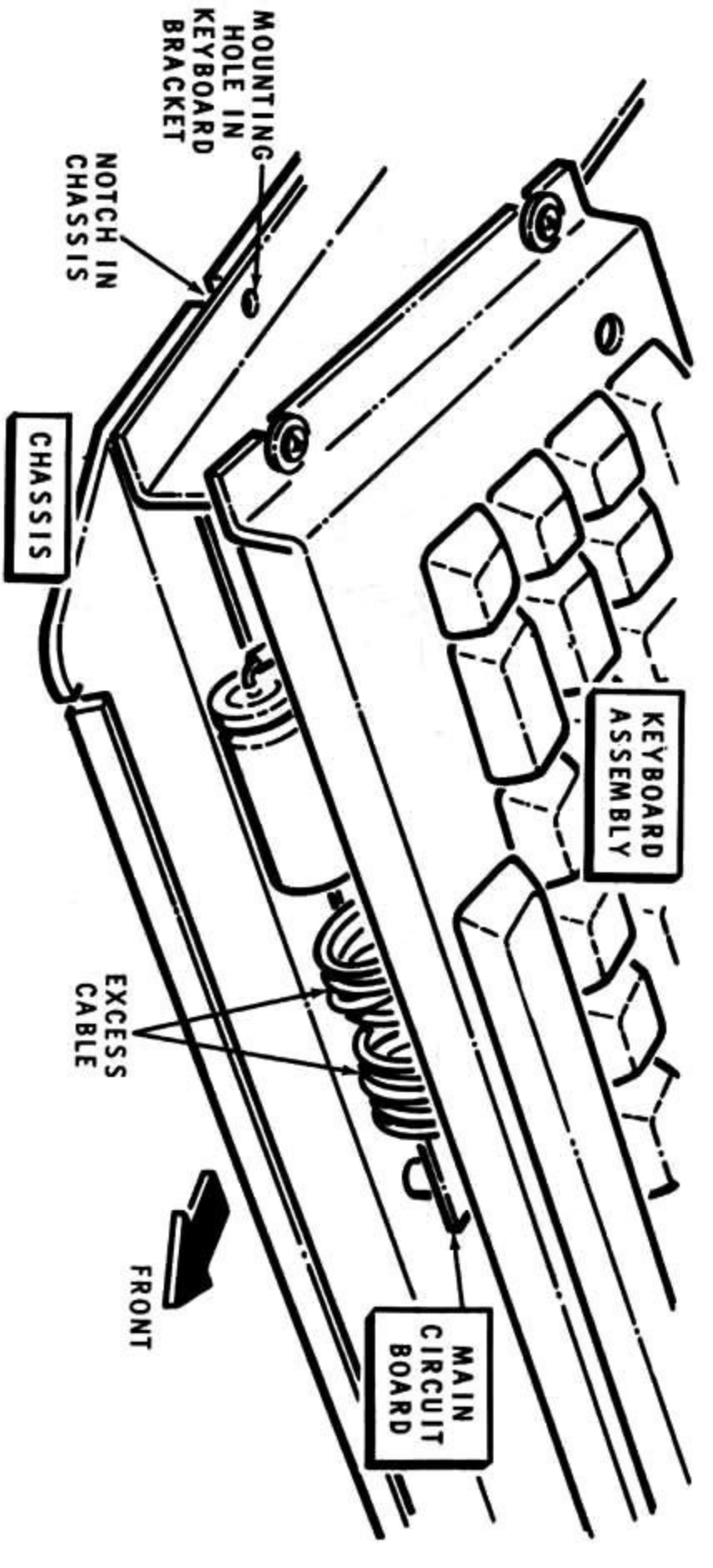

PICTORIAL 3-3

Detail 3-3A

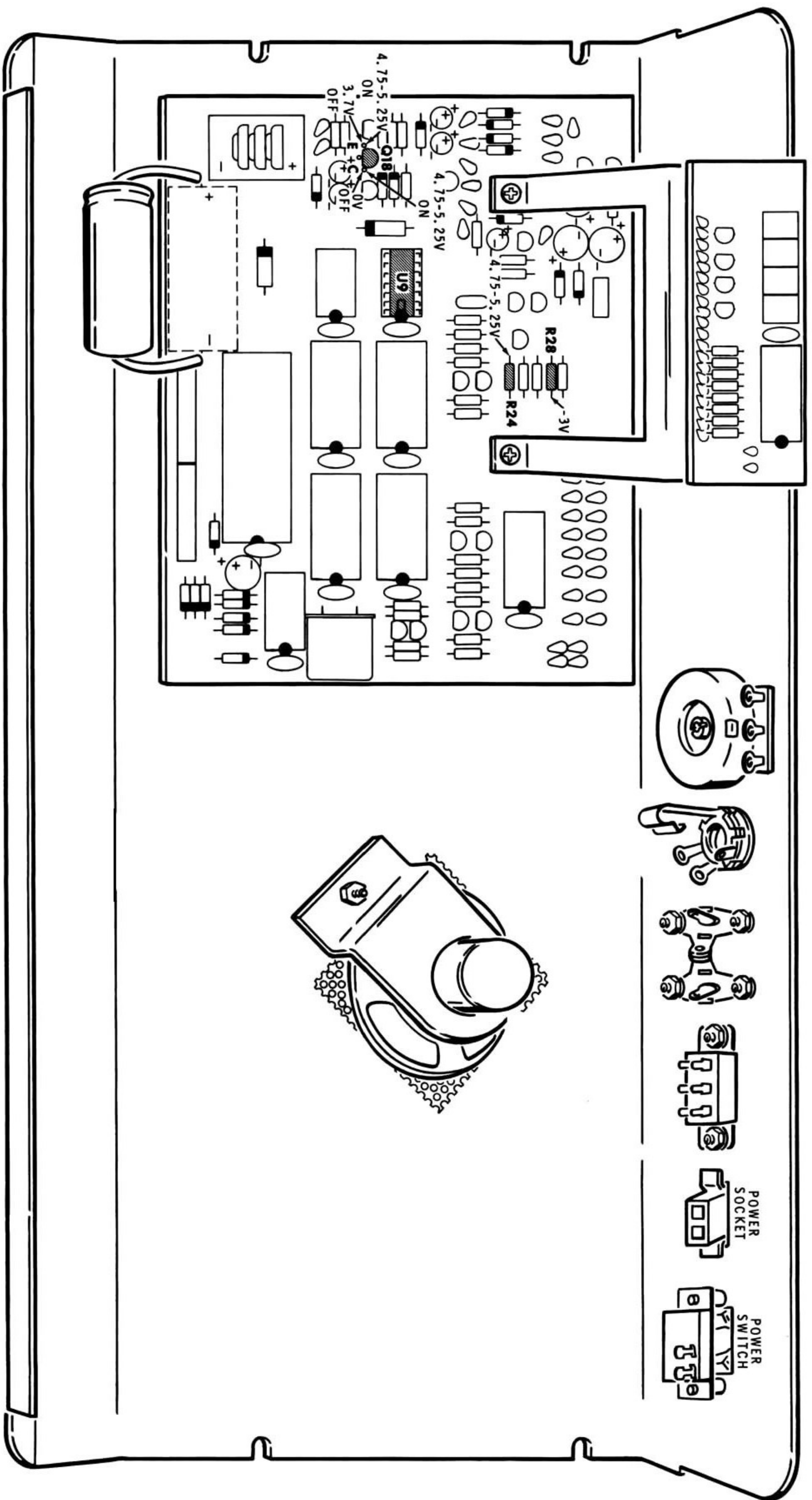

PICTORIAL 4-1

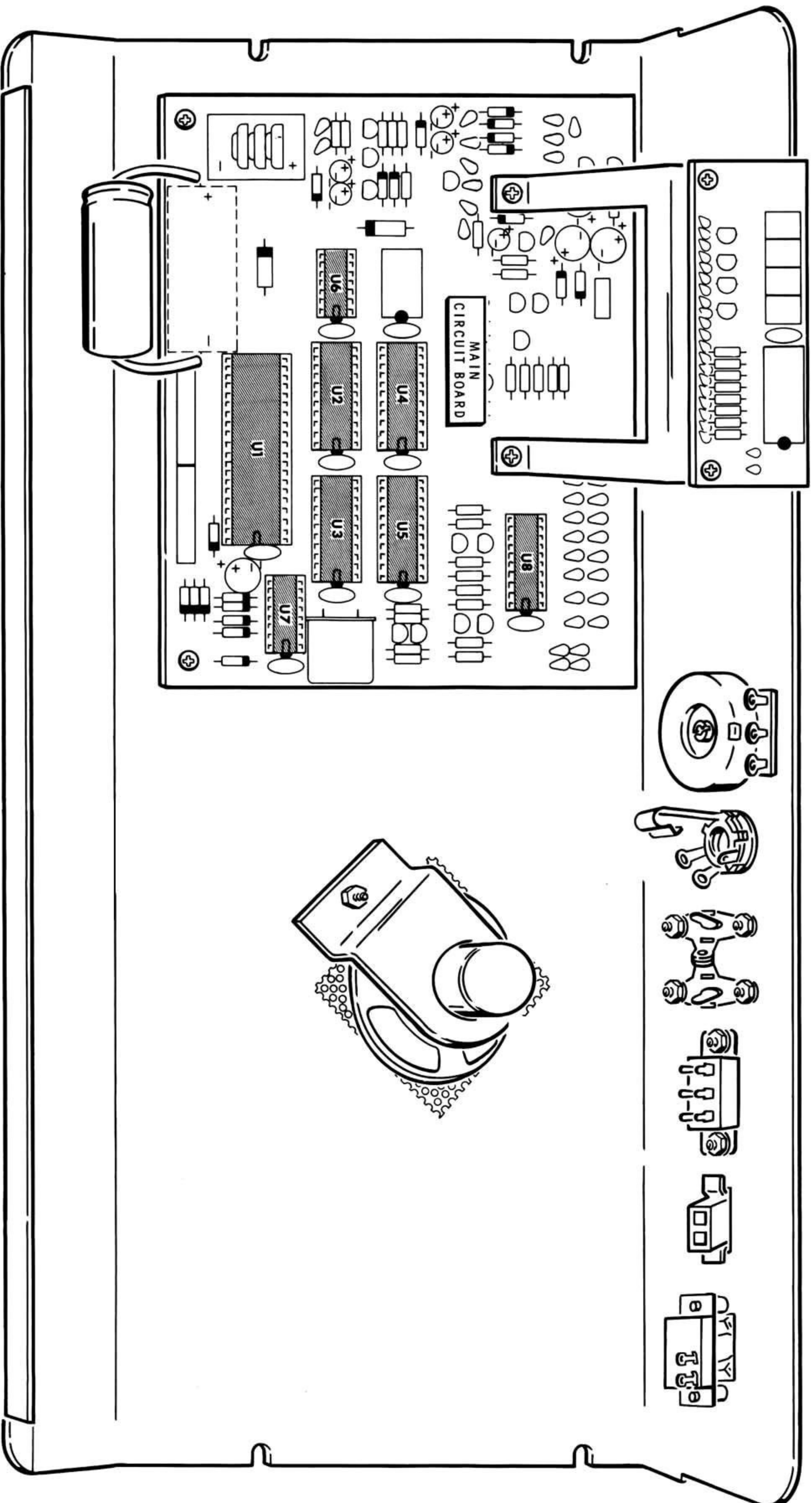

PICTORIAL 4-2

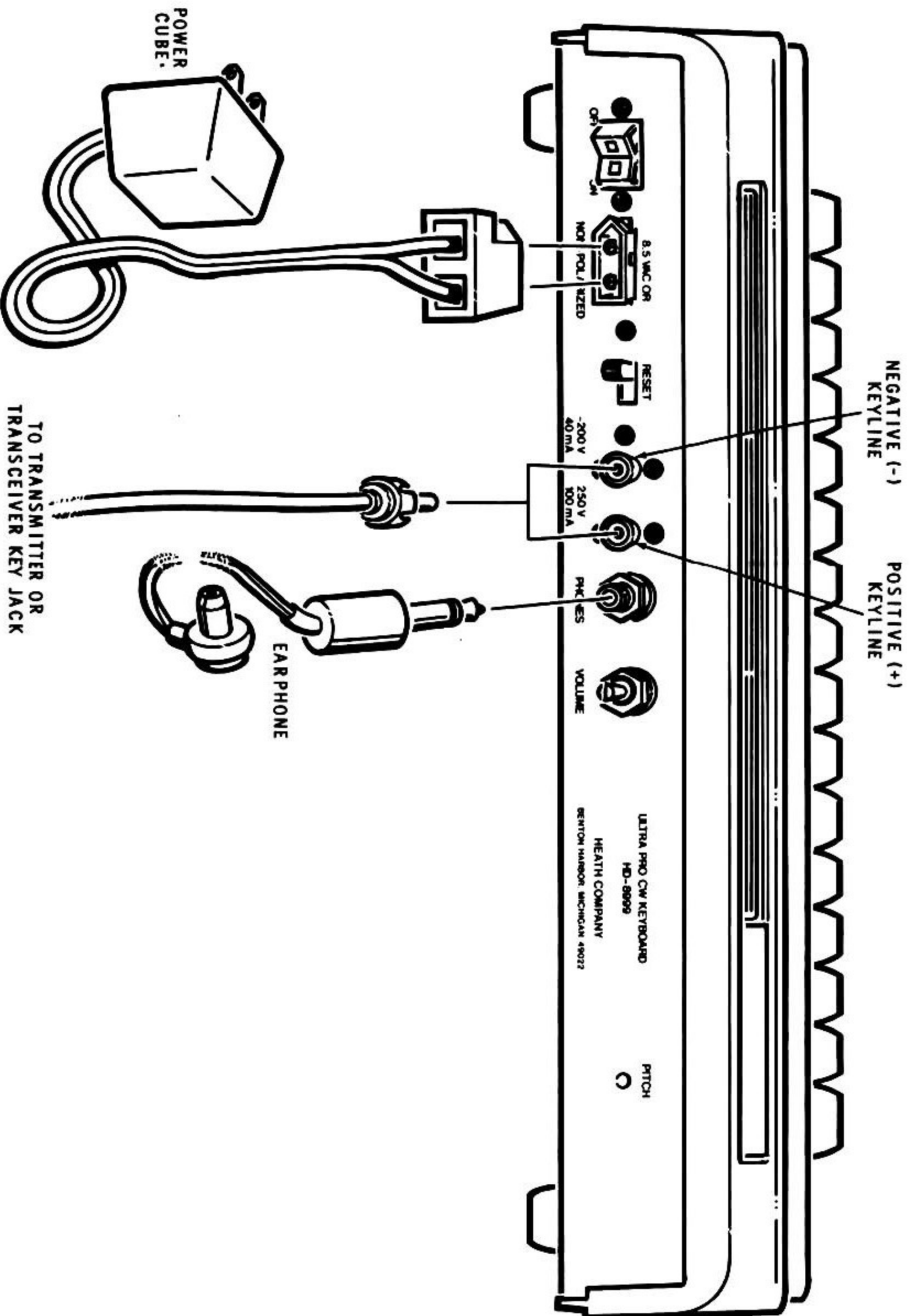

PICTORIAL 6-1

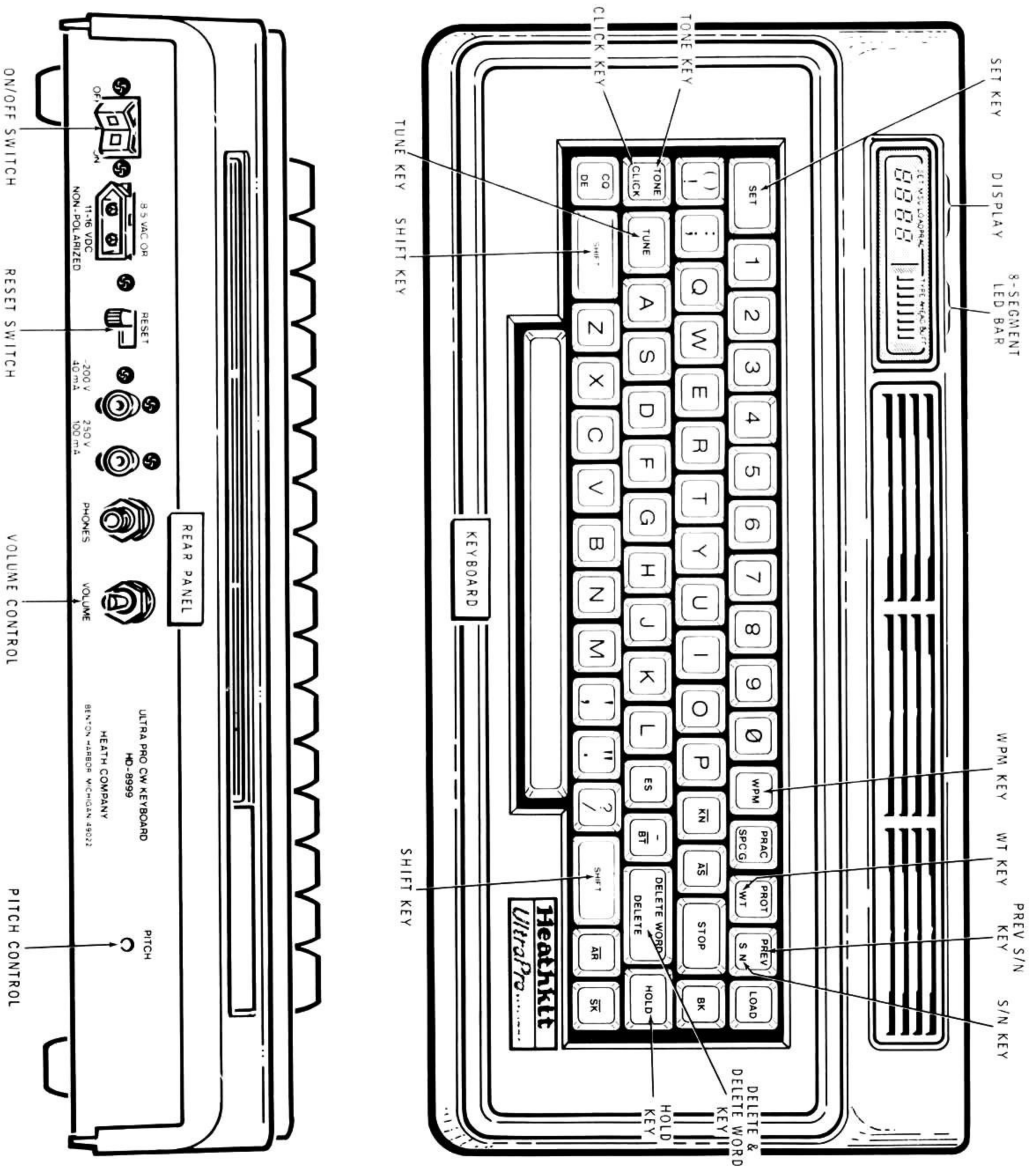

PICTORIAL 6-2



# CUSTOMER SERVICE

## REPLACEMENT PARTS

Please provide complete information when you request replacements from either the factory or Heath Electronic Centers. Be certain to include the **HEATH** part number exactly as it appears in the parts list.

## ORDERING FROM THE FACTORY

Print all of the information requested on the parts order form furnished with this product and mail it to Heath. For telephone orders (parts only) dial 616 982-3571. If you are unable to locate an order form, write us a letter or card including:

- Heath part number.
- Model number.
- Date of purchase.
- Location purchased or invoice number.
- Nature of the defect.
- Your payment or authorization for COD shipment of parts not covered by warranty.

Mail letters to: Heath Company  
Benton Harbor  
MI 49022  
Attn: Parts Replacement

**Retain original parts until you receive replacements. Parts that should be returned to the factory will be listed on your packing slip.**

## OBTAINING REPLACEMENTS FROM HEATH ELECTRONIC CENTERS

For your convenience, "over the counter" replacement parts are available from the Heath Electronic Centers listed in your catalog. Be sure to bring in the original part and purchase invoice when you request a warranty replacement from a Heath Electronic Center.

## TECHNICAL CONSULTATION

Need help with your kit? — Self-Service? — Construction? — Operation? — Call or write for assistance. you'll find our Technical Consultants eager to help with just about any technical problem except "customizing" for unique applications.

The effectiveness of our consultation service depends on the information you furnish. Be sure to tell us:

- The Model number and Series number from the blue and white label.
- The date of purchase.
- An exact description of the difficulty.
- Everything you have done in attempting to correct the problem.

Also include switch positions, connections to other units, operating procedures, voltage readings, and any other information you think might be helpful.

**Please do not send parts for testing**, unless this is specifically requested by our Consultants.

Hints: Telephone traffic is lightest at midweek — please be sure your Manual and notes are on hand when you call.

Heathkit Electronic Center facilities are also available for telephone or "walk-in" personal assistance.

## REPAIR SERVICE

Service facilities are available, if they are needed, to repair your completed kit. (Kits that have been modified, soldered with paste flux or acid core solder, cannot be accepted for repair.)

**If it is convenient, personally deliver your kit to a Heathkit Electronic Center. For warranty parts replacement, supply a copy of the invoice or sales slip.**

If you prefer to ship your kit to the factory, attach a letter containing the following information directly to the unit:

- Your name and address.
- Date of purchase and invoice number.
- Copies of all correspondence relevant to the service of the kit.
- A brief description of the difficulty.
- Authorization to return your kit COD for the service and shipping charges. (This will reduce the possibility of delay.)

Check the equipment to see that all screws and parts are secured. (Do not include any wooden cabinets or color television picture tubes, as these are easily damaged in shipment. Do not include the kit Manual.) Place the equipment in a strong carton with at least **THREE INCHES** of *resilient* packing material (shredded paper, excelsior, etc.) on all sides. Use additional packing material where there are protrusions (control sticks, large knobs, etc.). If the unit weighs over 15 lbs., place this carton in another one with 3/4" of packing material between the two.

Seal the carton with reinforced gummed tape, tie it with a strong cord, and mark it "Fragile" on at least two sides. Remember, the carrier will not accept liability for shipping damage if the unit is insufficiently packed. Ship by prepaid express, United Parcel Service, or insured Parcel Post to:

Heath Company  
Service Department  
Benton Harbor, Michigan 49022



HEATH COMPANY • BENTON HARBOR, MICHIGAN  
**THE WORLD'S FINEST ELECTRONIC EQUIPMENT IN KIT FORM**

LITHO IN U.S.A.